



*lighting*

 **GMR ENLIGHTS**  
Shaping Your Lighting World







*lighting*

 **GMR** ENLIGHTS



# Shaping your Lighting World

Siamo un'azienda italiana di illuminazione con una filosofia precisa: rispondere con la gamma Total Lighting Solution alle esigenze di illuminazione di un mondo Smart, in continua evoluzione, proiettato verso un futuro sostenibile incentrato su risparmio energetico e rispetto ambientale.

Assicuriamo efficienza, eleganza e qualità ad ogni angolo di strada, nei viali delle città, nelle grandi aree, lungo le autostrade e nelle zone abitative, dove la luce è una risorsa preziosa, che genera sicurezza e serenità.

**Siamo GMR ENLIGHTS.**

Diamo forma alla luce per illuminare un mondo nuovo.

*We are an Italian lighting company with a precise philosophy: to offer a Total Lighting solution to answer the needs of an ever-evolving Smart world driven towards a sustainable future, focused on energy saving and respect for the environment.*

*We ensure efficiency, elegance and quality at every corner, in the city boulevards, the large industrial and commercial estates, along the motorways and in residential areas where light is an invaluable resource that promotes well-being and leads to serenity.*

**We are GMR ENLIGHTS.**

*We shape light to enlighten a new world.*





# Total Lighting Solution

Offriamo ai nostri clienti una gamma "Total Lighting Solution": un mondo di soluzioni complete, intelligenti e performanti adatte a qualsiasi contesto ed esigenza installativa.

La nostra gamma spazia dalle armature stradali ai proiettori, dai pali di design moderno e contemporaneo ad una collezione storica di lampioni e corpi illuminanti artistici per l'illuminazione classica. Ogni nostro prodotto è caratterizzato da design italiano, elevata performance illuminotecnica, attenzione alla sostenibilità ambientale e cura della qualità costruttiva per garantire durabilità e ridotta manutenzione.

Possiamo combinare le nostre soluzioni di illuminazione con prodotti di arredo urbano, oggetti dal design raffinato, moderno o classico, frutto della nostra esperienza decennale nella definizione dei canoni del decoro urbano delle principali città storiche.

*We offer our clients a "Total Lighting Solution": a complete range of intelligent and high-performance solutions suitable for any situation and installation requirement.*

*Our collections range from street lighting to floodlights, from modern and contemporary poles to a historical collection of streetlights and artistic luminaires for classic lighting. Each of our items denotes Italian design, high performance, observation to environmental sustainability, attention to detail and quality to ensure durability minimising maintenance.*

*We can combine our lighting solutions with our urban furniture products that have an exquisite modern or classic style, culmination of decades of experience in defining standards in the urban décor of major historical cities.*

## urban furniture



Elementi di arredo urbano che coniugano stile, qualità, funzionalità e rispetto per l'ambiente, valorizzando le caratteristiche e le peculiarità degli spazi in cui sono inseriti.

*Urban décor elements that bring together quality, functionality and respect for the environment, enhancing the characteristics and peculiarities of the space where they are integrated.*

02

GMR ENLIGHTS

26

Optical flexibility

34

illuminazione stradale // street lighting

106

Proiettori // floodlights

136

Contemporaneo // contemporary

296

Design

illuminazione di arredo urbano // urban lighting

370

illuminazione artistica // classic lighting

Izar

34



laFoglia

56



Tarus

108



Woltron

114

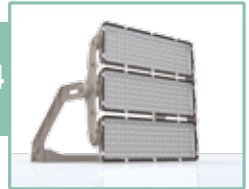

Vesta

136



Virgo

174



Krom

296



Aquilone

308



370



corpi illuminanti artistici // classic lighting fixtures

412



\*  
\*

ghisa-acciaio // cast-iron and steel



**Rondò**

74



**Orn**

96



**Cube**

122

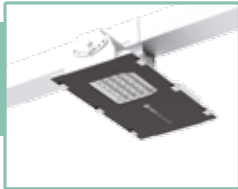

**Hibra**

130

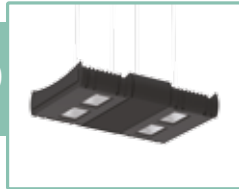

**Hulla**

192



**Esa**

220



**acciaio // steel**

252

\*



**Pharos**

282



**Camelot**

328



**Meldans**

344



**Yumi**

362



514

\*\*\*

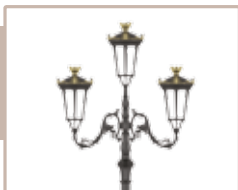

**ghisa**  
*cast-iron*

586



**attacchi a soffitto**  
*ceiling suspension systems*

596



**bollard in ghisa**  
*cast-iron bollards*

\* **Acciaio** è una collezione di pali, mensole a palo e mensole a muro abbinabili ai corpi illuminanti Izar, laFoglia, Rondò, Orn, Vesta, Virgo, Hulla, Esa.

*Steel* is a complete range of poles, pole arms and wall brackets that complement the Izar, laFoglia, Rondò, Orn, Vesta, Virgo, Hulla, Esa light fixtures.

\* **Ghisa-acciaio** è una collezione di pali, mensole a palo e mensole a muro abbinabili ai corpi illuminanti artistici.

*Cast-iron and steel* is a complete range of poles, pole arms and wall brackets that complement the classic lighting fixtures.

\* **Ghisa** è una collezione di pali, mensole a palo e mensole a muro abbinabili ai corpi illuminanti artistici.

*Cast-iron* is a collection of poles, pole arms and wall brackets that complement our classic lighting fixtures.





Linee di produzione automatizzate // *Automated packaging system.*



Sistema di imballo completamente automatizzato // *Automated Manufacturing line.*

# GMR ENLIGHTS

La nostra sede operativa si trova a Bertinoro e ospita le funzioni amministrative, commerciali, tecniche, produttive (reparto lighting) e logistiche, in un'ottica di ottimizzazione del sistema aziendale. Nello stesso complesso è dedicato ampio spazio ai laboratori per il test e la valutazione diretta della performance del prodotto. Lo stabilimento produttivo di Specchia (Lecce) è dedicato alla produzione dei pali e della carpenteria e alla lavorazione dei metalli. Lo stesso stabilimento è dedicato alle lavorazioni su ghisa, alluminio e bronzo, per i pali classici e per i prodotti decorativi di arredo urbano, ed è specializzato nel restauro di elementi d'arredo storici.

*Our Headquarters in Bertinoro hosts administrative, commercial, technical, manufacturing (lighting) and logistical operations thus optimising company resources. The same building houses a large area dedicated to laboratories for product testing and performance evaluation. The production plant in Specchia (Lecce) is specialised in pole manufacturing, sheet metal work and processing different types of alloys. The same plant handles the cast iron, aluminium and bronze works for our classic poles including the decorative parts of urban furniture. It also specialises in the restoration of historical decorative structures.*

## Certificazioni Aziendali // Company Certification



La certificazione **ISO 9001** attesta la capacità di **GMR ENLIGHTS** di condurre processi aziendali e realizzare prodotti all'interno di un sistema di gestione della qualità. Questa certificazione garantisce il rispetto degli standard e delle normative vigenti nei processi di progettazione e produzione.

*ISO 9001 certification states **GMR ENLIGHTS** ability of conducting manufacturing process and create high quality products. This certification ensures compliance with design and production processes standards and regulations in force.*



Grazie alla certificazione **ISO 14001**, **GMR ENLIGHTS** analizza, gestisce e controlla il proprio impatto sull'ambiente. Ci impegniamo ad attuare una politica aziendale che rispetti tutte le prescrizioni legali e le indicazioni riguardanti aspetti ambientali significativi. Siamo da sempre orientati a migliorare le condizioni di salute e sicurezza dei nostri dipendenti.

*Thanks to **ISO 14001** certification, **GMR ENLIGHTS** studies examines, manages and controls its impact on the environment. We are committed to following all rules and regulations concerning significant environmental matters. We have been always focused on improving the health and safety conditions of our employees.*

# Tradition, Design and Performance



1863

Le nostre origini risalgono alle "Officine di Forlì", una delle prime industrie private della Romagna e capostipite del movimento industriale della città. Le Officine realizzano, poco dopo la loro fondazione, un moderno impianto di illuminazione a gas per Forlì e producono "graziosi candelabri" per i viali e le piazze delle città italiane.

*Our origins date back to "Officine di Forlì", one of the first private businesses of Romagna and precursor of the city's industrial movement. Shortly after its foundation, "Officine Forlì" conceive a modern gas lighting system for the city of Forlì and manufacture charming candelabras for boulevards and squares of Italian cities.*



1958

Lo stabilimento viene acquisito dalla Bartoletti Spa che nel 1987 con la ditta Fondart di Bertinoro, di proprietà della famiglia Ravaoli, costituisce una nuova società: le Fonderie di Forlì Spa. In questo momento negli archivi delle "Officine di Forlì" viene ritrovato il patrimonio di disegni e progetti realizzati tra la fine dell'Ottocento ed i primi anni '30 del Novecento che diventeranno il punto di riferimento e di ispirazione per la nascente Ghisamestieri.

*The plant is acquired by Bartoletti Spa and in 1987 together with the Fondart, a company in Bertinoro, owned by the family Ravaoli, a new company is founded: Fonderie di Forlì Spa. During this time, a legacy of drawings and projects, dating back to the end of the nineteenth century and beginning of the 1930's, are rediscovered in the archives of "Officine di Forlì" and become the reference point and inspiration for the emerging Ghisamestieri.*



1993

Ghisamestieri subentra alle Fonderie di Forlì e inaugura la sua attività con prestigiose opere di restauro dei pali in ghisa delle più belle città italiane: Venezia, Palermo, Napoli e Milano.

*Ghisamestieri assumes control of Fonderie di Forlì and inaugurates their business with prestigious cast iron pole restorations from the most beautiful Italian cities: Venice, Palermo, Naples and Milan.*



2001

Dall'amicizia privata tra Leardo Ravaoli, il fondatore di Ghisamestieri, e Dino Gavina, una delle figure imprenditoriali più importati nel settore dell'arredamento italiano, nasce l'idea di unire esperienze e capacità produttive per realizzare una linea di arredo urbano di alto design. Comincia per Ghisamestieri la collaborazione con designer e architetti di calibro internazionale.

*The private friendship between Leardo Ravaoli, founder of Ghisamestieri, and Dino Gavina, one of the most important entrepreneurs in the Italian furniture sector, gives birth to the idea of combining experiences and production capacity to achieve an exclusive line of urban furniture. For Ghisamestieri this is the beginning for collaborations with international designers and architects.*

# SINCE 1863



2009

**Ghisamestieri sviluppa il primo sistema modulare a tecnologia LED e lo applica al proprio patrimonio di corpi illuminanti a scarica. Nasce una collezione di prodotti che uniscono design artistico e innovazione tecnologica.**

*Ghisamestieri develops the first modular LED technology system and applies it to its legacy of discharge lamp fixtures. A new collection of products is born that combine artistic design and innovative technology.*



2016

**In occasione di light+building Ghisamestieri presenta la nuova linea di prodotti stradali ed urbani a LED "lightecture" che segna l'inizio di un grande cambiamento. Ghisamestieri estende la propria gamma di prodotti oltre l'illuminazione artistica e si spinge verso un mercato sempre più internazionale.**

*During the light + building event Ghisamestieri presents "lightecture" a new line of street and urban products based on LED technology that marks the beginning of big change. Ghisamestieri extends its product range beyond artistic lighting and pushes the boundaries towards an increasingly international market.*



08.06.2020

**Dopo una lunga storia GhisaMestieri si rinnova. Nasce GMR ENLIGHTS: un brand che mantiene intatte origini e know-how di sempre, ma che si apre alla propria vocazione internazionale ed a nuovi settori dell'illuminazione professionale.**

**Un nome in linea con le nuove esigenze di illuminazione di un mondo smart in continua evoluzione, proiettato verso un futuro sostenibile.**

*After a long history, GhisaMestieri renews itself. GMR ENLIGHTS is born: a brand that maintains intact its origins and its know-how, that reaffirms its international vocation and receptiveness towards new professional lighting sectors. A name that is in line the lighting requirements of a smart world, headed towards a sustainable future.*



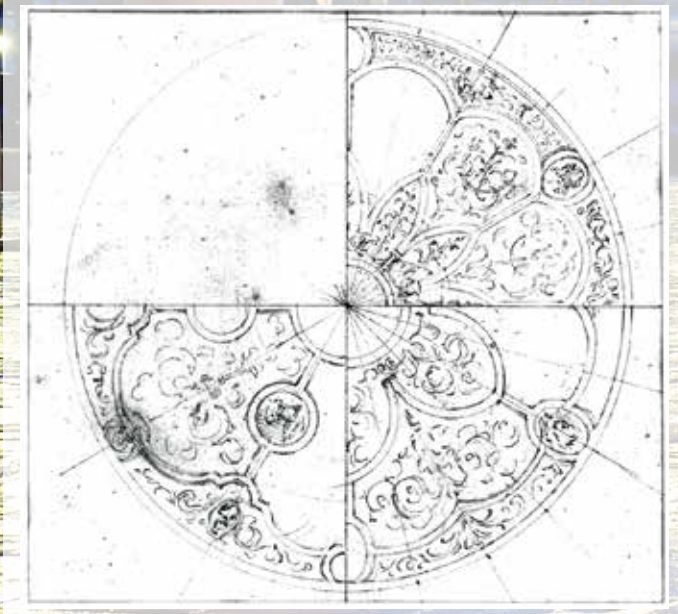

Disegni realizzati nel 1881 | Drawings produced in 1881

---

# Tradition

Le nostre origini affondano nel calore della fonderia e nella lavorazione di un materiale, la ghisa, che richiede conoscenza razionale e sapienza artigianale.

A partire dagli anni Novanta abbiamo condotto importanti opere di restauro sull'illuminazione artistica delle più prestigiose città italiane.

La responsabilità di lavorare al patrimonio storico dei lampioni in ghisa ci ha trasmesso quell'attenzione ai dettagli e quella cura dei particolari su cui ancora oggi fondiamo ogni nostra attività.

Abbiamo vissuto la rapida evoluzione del mondo dell'illuminazione arricchendo progressivamente di conoscenze illuminotecniche ed ottiche la consolidata esperienza nel campo della metallurgia.

La collaborazione con designer di calibro internazionale, architetti, progettisti ed esperti del settore illuminotecnico, ha portato ad una progressiva integrazione tra sperimentazione tecnica e design, artigianato ed industria, ponendo le basi per la multidisciplinarietà e l'originalità creativa che caratterizzano il nostro lavoro.

*Our origins lie in the warmth of the foundry handling material like cast iron, which requires rational knowledge and craftsmanship. Since the nineties we have conducted important artistic lighting restorations in the most prestigious Italian cities.*

*The responsibility to work on such important historical cast iron lampposts has given us that attention to detail on which we still base all our activities.*

*We have experienced the rapid evolution in the world of lighting, enriching progressively our knowledge of illumination and metallurgy. Collaboration with internationally renowned designers, architects, and lighting experts has led to a progressive integration between technical experimentation and design, crafts and industry, laying the foundations for a multidisciplinary originality that distinguishes our work.*





---

# Design

La luce è il principio ideativo e la finalità che ci guida nella realizzazione del prodotto. La luce emessa, in abbinamento all'estetica dell'involucro, è la modalità con cui il corpo illuminante instaura un dialogo con il contesto. Per questo prestiamo particolare attenzione all'ideazione e alla costruzione di sistemi ottici, in perfetta armonia con l'estetica e la forma del prodotto.

Il design del prodotto, spesso sviluppato in collaborazione con architetti e professionisti, viene accompagnato da un'analisi combinata di esigenze illuminotecniche e norme di riferimento. Le ipotesi iniziali vengono sviluppate con il disegno tecnico tramite l'utilizzo di specifici software, fino alla genesi dei prototipi che consentono una verifica estetica del percorso intrapreso.

*Light is the main principle and reason that guides us while developing our products. The combination of Light and aesthetics is the way in which the light fixture interacts with its surroundings. This is the reason why we pay so much attention to the design and development of our optical systems ensuring perfect harmony with the style of our products.*

*The aesthetical design, that is often developed in collaboration with architects and designers, is driven by a complete analysis of the lighting requirements and standards. The initial concepts are drawn up with dedicated design software and lead to the inception of the prototypes to verify and validate the aesthetics.*



# Performance

## LED Technology

Il LED ha cambiato il modo di pensare e progettare la luce. GMR ENLIGHTS offre una serie di soluzioni ad alto valore estetico e progettuale, perfettamente coniugate alla migliore tecnologia LED. La mission aziendale focalizza l'attenzione su tematiche sensibili, come la diminuzione del consumo energetico, la riduzione delle emissioni di CO2, l'incremento della vita della sorgente luminosa abbattendo così le operazioni di manutenzione e introducendo la possibilità di dimmerare l'emissione luminosa e controllare punto-punto lo stato di salute dell'apparecchio.

*LED technology has changed the way we think and design with light. GMR ENLIGHTS offers a wide range of solutions with a distinguished design combined with the latest and best LED technology. The company's main focus is the consideration for sensitive matters, such as decreasing energy consumption, reducing CO2 emissions, thus increasing lifespan and limiting maintenance, and providing dimming control and remote management.*



### Energy Saving

La tecnologia LED permette un risparmio energetico effettivo tra il 50% e l'80%. Il nostro obiettivo è la continua ricerca di soluzioni tecnologiche che riducano i consumi e migliorino le prestazioni illuminotecniche.

*LED technology ensures energy savings from 50% up to 80%. Our goal is the constant search for technological solutions that limit energy consumption and improve lighting performance.*



### Long Life

Tutti i prodotti GMR ENLIGHTS fanno uso di sorgenti LED in grado di garantire la massima durata di vita utile dell'apparecchio, con un decadimento tipico del flusso luminoso pari a L90B10 100.000h (protocollo LM80 – TM21)

*All GMR ENLIGHTS use LED sources capable of maximising the lifespan of the apparatus, with a typical degradation of the luminous flux in compliance with L90B10 100.000hrs (LM80 - TM21 protocol)*



### Quality

Utilizziamo le migliori sorgenti LED presenti sul mercato. Lavorando a stretto contatto con il fornitore abbiamo individuato e adottato in esclusiva una selezione particolare del LED che garantisce una coerenza cromatica  $\leq 3$  STEP Mc ADAM.

*We use the best LEDs and work closely with the manufacturer. We have identified and approved a specific selection of LEDs that guarantee a colour consistency  $\leq 3$  MacAdam steps.*

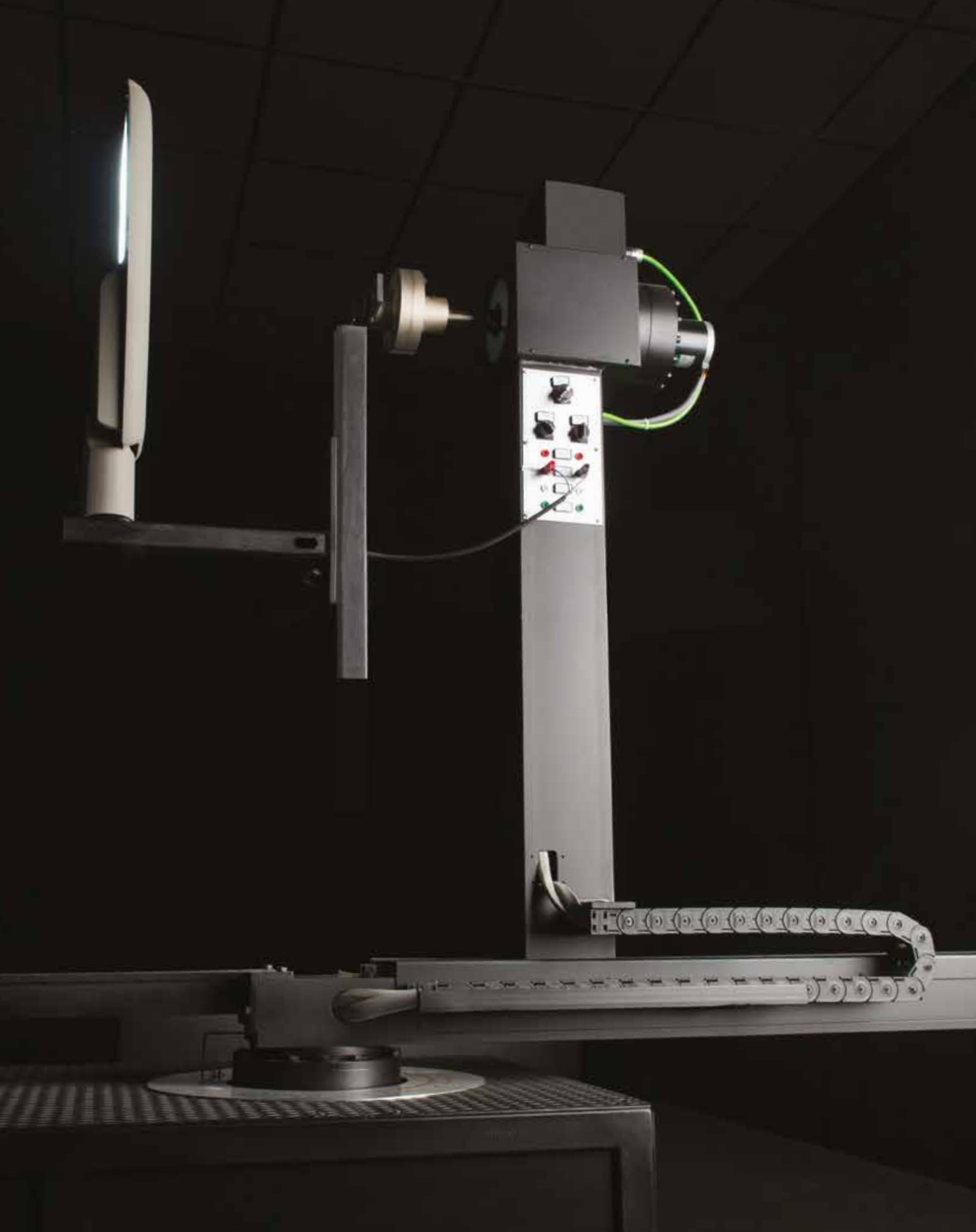

## Lighting Performance

Il laboratorio fotometrico interno all'azienda consente la verifica delle performance illuminotecniche di ogni prodotto sin dalla fase ideativa. L'analisi fotometrica, condotta da personale specializzato in conformità alla norma UNI EN 13032-1: 2005, ha per noi un ruolo centrale: non solo è uno strumento indispensabile per la validazione, ma ci consente di controllare la post-produzione e costruire un database di dati attendibili per il supporto al cliente.

*Our inhouse photometric laboratory enables us to verify the lighting performance of each apparatus from its conception. The photometric analysis in conformity with UNI EN 13032-1:2005, conducted by our engineers is paramount for us: not only an indispensable instrument for validation but allows us also to perform post-production examination and develop a credited database to support our customers.*



**PHOTOBIOLOGICAL  
SAFETY**  
**CLASS 0 - EXEMPT GROUP**  
IEC / TR62471



### Cutoff

I nostri prodotti, progettati nell'ottica di un controllo totale della distribuzione luminosa, non consentono l'emissione di luce verso l'alto.

*Our products are designed from the ground up to have full control of the light distribution, avoiding skyward light.*



### Optical Flexibility

I prodotti GMR ENLIGHTS sono progettati per "distribuire la luce solo dove serve": l'ampia gamma di sistemi ottici disponibili consente di distribuire il flusso luminoso in funzione dell'ambito di applicazione.

*GMR ENLIGHTS products are designed to "distribute light only where it is needed": our wide range of optical systems allows us to specifically distribute the luminous flux according to the desired area of application.*



### Low Glare

Abbiamo progettato e sviluppato i sistemi ottici dei nostri apparecchi per assicurare un elevato comfort visivo e minimizzare l'effetto puntiforme tipico dei LED.

*We design and develop the optical systems of our products to ensure high visual comfort and minimise the typical dot effect of LEDs.*





## Safety and Durability

Le condizioni ambientali e lo stress fisico, meccanico e termico a cui un dispositivo di illuminazione è inevitabilmente soggetto possono influire negativamente sull'emissione luminosa.

Per questo siamo alla continua ricerca di soluzioni che raggiungano il massimo delle prestazioni. La cura dei dettagli costruttivi trova largo spazio nella fase progettuale di ingegnerizzazione del prodotto. Il prototipo viene poi testato nei laboratori interni con prove IP, termiche e IK.

*The environmental conditions including mechanical and thermal stress to which a lighting device is inevitably subject, can adversely affect the light emission.*

*For this reason, we are constantly looking for solutions to achieve maximum performance. Our attention to detail finds ample space during the design and engineering phases. The consequent prototype undergoes IP, thermal and IK testing in our internal laboratories.*

### Certificazioni di Prodotto // Products Certification



Il marchio **CE** certifica che i prodotti **GMR ENLIGHTS** sono conformi ai requisiti di sicurezza previsti dalle direttive e regolamenti comunitari.

*The CE marking certifies that the GMR ENLIGHTS meet the safety requirements provided for by European Directives and regulations.*



I prodotti **GMR ENLIGHTS** sono progettati e costruiti seguendo tutte le normative europee di sicurezza, controllo e qualità in materia di "apparecchi di illuminazione a LED". Il marchio **ENEC** ne certifica la conformità.

*GMR ENLIGHTS products are designed and manufactured following all European quality control and safety standards regarding LED lighting fixtures. The ENEC marking certifies they conform.*



In conformità agli standard di riferimento, i test e i processi produttivi sono supervisionati da **DEKRA** Testing and Certifications S.r.l. al fine di garantire prodotti di alta qualità.

*In accordance with the reference standards, all tests and manufacturing processes are overseen by 'DEKRA Testing and Certifications S.r.l.' that guarantees high-quality standards of our products.*



I prodotti **GMR ENLIGHTS** sono conformi agli standard per la sicurezza elettrica degli apparecchi di illuminazione in USA e Canada grazie al marchio **ETL** che raccoglie tutte le normative di riferimento: UL, CSA, ANSI, ASTM e NFPA.

*GMR ENLIGHTS products conform to Canada and USA electrical standards concerning the safety of lighting fixtures. The ETL marking includes all reference standards such as: UL, CSA, ANSI, ASTM and NFPA.*





## Qualità delle finiture // Quality of the finishing touches

### Test Nebbia Salina // Salt Spray Test – ISO 9227

Le finiture esterne di tutti i nostri corpi illuminanti assicurano il massimo della durabilità anche in condizioni estreme, come in prossimità del mare o in zone particolarmente corrosive. I cicli di trattamenti superficiali e di verniciatura sono stati studiati e sperimentati per anni, con un costante lavoro di confronto con i fornitori. Il risultato è un successo senza precedenti: il conseguimento della certificazione da ente terzo per **8000h** di test in Nebbia Salina secondo la normativa **ISO 9227** (pari ad oltre 11 mesi di test continuativi.).

*The finishing touches of our light fixtures ensure maximum durability even in extreme conditions, like near the sea or in particularly corrosive sites. Our surface treatment and coating have been meticulously researched and improved over the years with constant evaluation together with our suppliers. The results are remarkable: a salt spray endurance test of **8000hrs** in accordance to **ISO 9227**, certified by recognised institute (this is equivalent to more than 11 months of consecutive testing).*



## Qualità dei sistemi di fissaggio // Quality of fastening systems

### Vibration Test – IEC 60068-2-6

Gli apparecchi GMR ENLIGHTS hanno superato il severo Vibration Test in conformità alla norma **IEC 60068-2-6** a frequenza critica specifica in ambienti a traffico motorizzato. Il test certifica la robustezza meccanica del corpo illuminante e la resistenza dei sistemi di fissaggio dell'apparecchio al palo, e attesta la qualità del prodotto e delle sue componentistiche elettriche, compresi i cablaggi.

*GMR ENLIGHTS light fixtures have passed the severe Vibration Test in accordance to **IEC 60068-2-6** to withstand critical vibration frequencies that are comparable to heavy motorised traffic environments. The test certifies the mechanical sturdiness of the main body and its pole attachment system, including the electrical components and wiring.*



## Alta Protezione ad intrusi ed urti IP66 e fino a IK10 //

### IP66 Ingress Protection and up to IK10 Impact Resistance

### IP Test // IK Test – CEI-EN 60598-2-3

Gli apparecchi GMR ENLIGHTS, come da certificazione ENEC, hanno grado di protezione alle intrusioni di corpi solidi e liquidi **IP66 e fino ad IK10** per la protezione contro urti meccanici esterni, pari ad una protezione di 20J di energia da impatto. I prodotti che non hanno raggiunto IK10 sono certificati IK09, pari alla protezione di 10J di energia da impatto.

*GMR ENLIGHTS light fixtures, as per ENEC certification, are **IP66** certified to protect against the ingress of solid objects and liquids, and up to **IK10** for the protection against external mechanical impacts, equivalent to a force of 20J. The devices that don't achieve IK10 are certified IK09, that corresponds to a protection of 10J of impact energy.*



# Safety and Durability

## • LAB Tests •

### Resistenza termica // Heat Resistance

Certificato ENEC Ta fino a +55°C // ENEC certification up to +55°C – CEI-EN 60598-2-3

Gli apparecchi GMR ENLIGHTS hanno ottenuto la certificazione europea ENEC ad **una temperatura ambiente di lavoro Ta -40° e fino a + 55°C.**

La bassa temperatura a cui lavora il chip LED è un dato molto importante che dimostra la cura che abbiamo utilizzato nello studio della dissipazione del calore fondamentale per assicurare la lunga vita delle sorgenti e del prodotto.

*GMR ENLIGHTS light fixtures have obtained the ENEC European certification to operate at **an ambient temperature of -40°C and up to + 55°C.***

*The low temperature at which the LED can reach is an important aspect that proves the emphasis that we put into heat dissipation research that is essential to maximising the lifespan of LED modules and the entire fixture.*

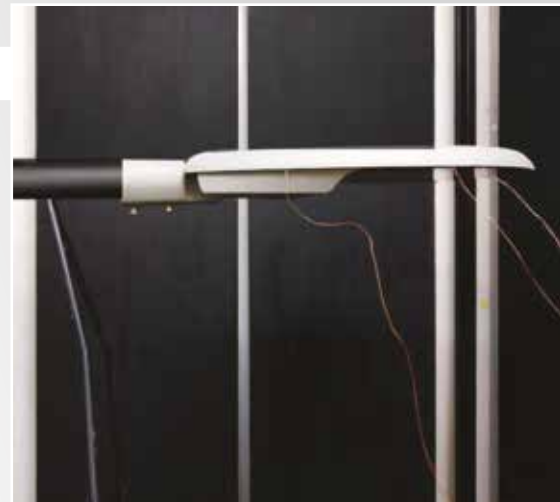

### Protezione contro scariche elettrostatiche e di sovratensione fino a 12kV

// Up to 12kV Overvoltage and Electrostatic Discharge protection

Test elettrici // Electrical tests – IEC EN 61000-4-5:2014

I corpi illuminanti GMR ENLIGHTS sono predisposti per garantire alta protezione del modulo LED contro sovratensioni elettrostatiche e rigidità dielettrica. Su richiesta possiamo ulteriormente integrare una protezione aggiuntiva SPD (Surge Protection Device) per proteggere tutto il corpo illuminante dai picchi di sovratensione **fino a 12 kV.**

*GMR ENLIGHTS light fixtures are developed ensure dielectric rigidity and protect the LED modules against electrostatic discharges. On request an additional SPD (Surge Protection Device) can be fitted to protect the fixture from surges **up to 12 kV.***

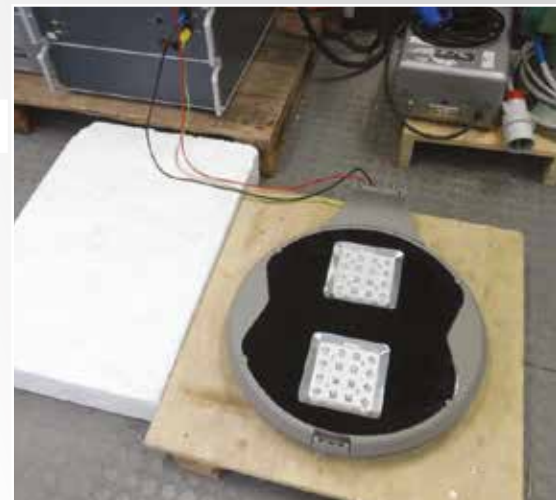





# Sustainability

La luce è una delle risorse energetiche più importanti che l'uomo ha a disposizione. L'attenzione alla sostenibilità ambientale e al rispetto del patrimonio naturale è una questione culturale che negli ultimi decenni ha investito ogni ambito di sviluppo economico e produttivo. Per questo abbiamo intrapreso un "percorso green" di scelte consapevoli, di continua ricerca e costante aggiornamento, per produrre una "luce giusta", sostenibile sia tecnicamente che funzionalmente.

*Light is one of the most valuable energy resources we have. Awareness to environmental sustainability and consideration of cultural and natural heritage is a topic that in the last decades has affected every aspect of economic development. For this reason, we have decided to adopt an environmentally 'green' mindfulness, with persistent research and development to deliver the "right light" that is technically and operationally sustainable.*



## Earth Saving

La tecnologia LED, abbinata alla nostra continua ricerca per migliorare l'efficienza, ha drasticamente ridotto le emissioni di CO2 nell'ambiente.

*Drastically reduced CO2 emissions thanks to the combination of LED technology and our continuous research to improve efficiency.*



## Zero Light Pollution

GMR ENLIGHTS progetta e produce per limitare o annullare l'inquinamento luminoso e lo spreco di energia: tutti i nostri apparecchi destinati all'illuminazione pubblica sono CUT-OFF e conformi alla normativa sull'inquinamento luminoso.

*GMR ENLIGHTS designs and manufactures solutions capable of minimising or eliminating light pollution and energy loss: all our public lighting devices are fully CUT-OFF and comply with light pollution regulations.*



## Life Cycle Thinking (LCT)

Utilizziamo in maniera sostenibile materiali e risorse e ci preoccupiamo di offrire soluzioni valide nel tempo che limitino le operazioni di manutenzione.

*All materials and resources are employed in a sustainable way as we care to offer solutions that stand the test of time, minimising the need of maintenance.*





I nostri prodotti sono progettati e realizzati nel rispetto di un'economia circolare, sempre più oggetto delle politiche mondiali sull'impatto ambientale. I corpi illuminanti GMR ENLIGHTS si distinguono sul mercato per le elevate prestazioni in tutti i parametri caratteristici rilevanti e costituiscono soluzioni di eccellenza sotto il profilo ambientale, integrando diversi sistemi di risparmio energetico tra cui dimmerazione e telecontrollo. L'introduzione delle sorgenti LED ci ha consentito di avviare un processo di miniaturizzazione dei corpi illuminanti, con una notevole riduzione della quantità di materiale impiegato per la produzione.

*Our products are designed and manufactured in compliance with a circular economy that is increasingly subject to worldwide environmental regulations. GMR ENLIGHTS fixtures excel for their high performance in all relevant parameters and represent excellence in environmental solutions by integrating different energy saving systems including dimming and remote control. The introduction of LED lighting has enabled the miniaturisation of the fixtures, with a considerable reduction of the amount of materials needed.*



Tutti i prodotti GMR ENLIGHTS sono conformi ai CAM – Criteri Ambientali Minimi (DM 27 Settembre 2017, G.U. n°244 del 18 Ottobre 2017) e forniscono i più alti gradi di classificazione energetica IPEA\*

*All GMR ENLIGHTS products comply with CAM – Minimum Environmental Criteria (Ministerial Decree - 27th September 2017, Official Gazette No. 244 - 18th of October 2017) and provide the highest IPEA\* grades of energy classification*





# Accessibility

I prodotti GMR ENLIGHTS sono stati sviluppati per facilitare accessibilità e manutenzione. È possibile aprire la maggior parte degli apparecchi e sostituire i componenti interni senza l'utilizzo di utensili. In alcuni casi per non compromettere il design del prodotto o per garantire la migliore soluzione tecnica sono state sviluppate specifiche soluzioni di accessibilità.

*GMR ENLIGHTS products have been developed for easy accessibility and maintenance. Most of our devices are openable and the internal components can be replaced without need of tools. We have often developed specific accessibility solutions to avoid compromising the aesthetics or simply ensure the best technical solution.*



## Timeless



Apparecchio apribile e rigenerabile, componentistica interna sostituibile  
SENZA utilizzo di utensili.

*The light fixture is openable and renewable, the internal components are replaceable without need of tools.*

## Openable



Apparecchio apribile e rigenerabile, componentistica interna sostituibile  
CON utilizzo di utensili.

*The light fixture is openable and renewable, the internal components are replaceable using basic tools*



## Compact



Apparecchio sigillato fornito con cavo di alimentazione e connettore rapido IP68 per installazione immediata.

*Sealed fixture with power cable and IP68 electrical connector for quick and simple installation.*



# Optical technologies

GMR ENLIGHTS possiede un know-how tecnico completo che ha consentito di progettare e sviluppare differenti tecnologie ottiche per gli apparecchi di illuminazione a LED. Ogni tecnologia ha peculiarità e vantaggi specifici. La scelta del miglior sistema ottico è determinata in funzione del progetto illuminotecnico, dell'applicazione o del prodotto selezionato.

*GMR ENLIGHTS technical experience has enabled it to develop different optics for its LED light fixtures. Each optic system has its own peculiarities and specific advantages. Choosing the best optics is based on the light calculation, the application and selected light fixture.*



## Glassed

Sistema ottico a rifrazione composto da single-chip LED, lenti in PMMA garantite 30 anni contro UV e ingiallimento da invecchiamento, recuperatore in alluminio con grado di purezza 99,7% e vetro extra chiaro temperato.

*Refractive optical system consisting of single-chip LED, PMMA lenses with 30 years guarantee against UV rays and yellowing effect, a 99.7% purity aluminium reflector and extra clear tempered glass screen.*



## Glass-free

Sistema ottico a rifrazione composto da single-chip LED, lenti ad alta resistenza anti-urto e garantite 30 anni contro UV e ingiallimento da invecchiamento (senza vetro).

*Refractive optical system consisting of single-chip LED, shockproof PMMA lenses with 30 years guarantee against UV rays and yellowing effect. No glass screen (Glass-Free).*



## Reflexa R

Sistema ottico a riflessione composta da single-chip LED, riflettore in alluminio extra-puro con trattamento PVD in argento e vetro extra chiaro temperato.

*Reflective optical system consisting of single-chip LED, extra-pure aluminium reflector with silver PVD coating and extra clear tempered glass screen.*

**Ottiche disponibili p.26 // Available optics p.26**

**Type 1 - Type 2 - Type 3 - Type 4 - Type 5**

**Type Architectural: 6 180°, 6 360°, 7, 8 - Type Floodlights: 9,10,11**

**Ottiche disponibili p.26 // Available optics p.26**

**Type R1 - Type R2 - Type R3 - Type R5**

**Type Floodlights: R9, R10, R11**



## **Optical Flexibility**

- 26 **Optic - Type 1 / Type R1**
- 27 **Optic - Type 2 / Type R2 / Type 3 / Type R3**
- 28 **Optic - Type 4**
- 29 **Optic - Type 5 / Type R5**
- 30 **Optic - Type COMBO**
- 31 **Optic - Type Architectural**
- 32 **Optic - Type Floodlights**



**OPTIC**  
**Type 1 / Type R1**



Type 1



Type R1

**Applicazioni // Applications:**

Strada urbana // *Urban street*

Strada residenziale // *Residential street*

Centro strada // *Street centre*

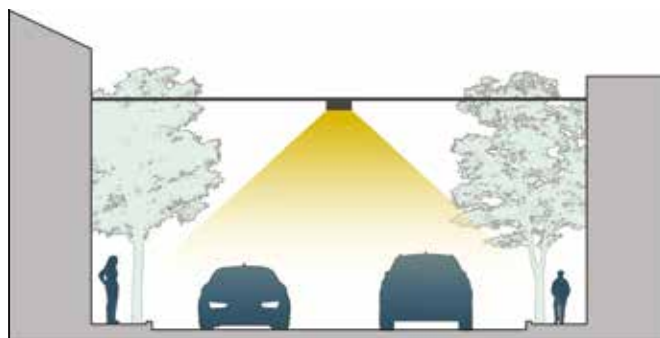

Distribuzione luminosa simmetrica.  
Ottica idonea per l'installazione  
a sospensione su centro strada.

*Symmetrical light distribution.  
Optic type suitable to be installed  
in the middle of the street.*



Strada urbana  
*Urban street*



Strada residenziale  
*Residential street*



Centro strada  
*Street centre*

## OPTIC

### Type 2 / Type R2 / Type 3 / Type R3



Type 2



Type R2



Type 3



Type R3

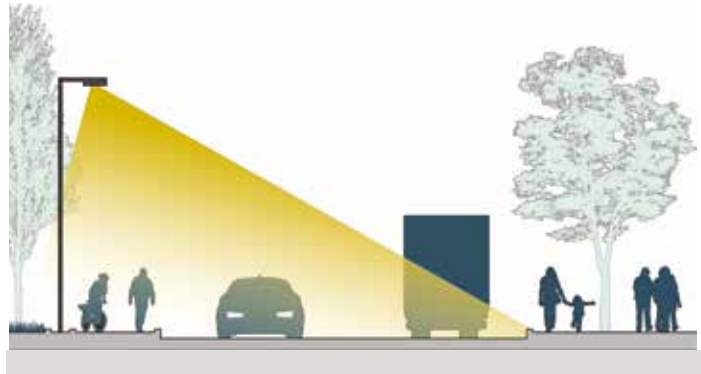

Distribuzione luminosa asimmetrica.  
 Ottica idonea per l'illuminazione stradale  
 e su percorsi ciclo-pedonali.  
 Le ottiche sono disponibili in diverse asimmetrie  
 in funzione della geometria di installazione.

*Asymmetrical light distribution. Optic designed  
 to suit street lighting, pedestrian and bicycle paths.  
 Available in different asymmetric geometries according  
 to the road type.*

#### Applicazioni // Applications:

Viale pedonale // *Pedestrian path*  
 Pista ciclabile // *Cycle path*  
 Strada extraurbana // *Suburban street*  
 Strada urbana // *Urban street*  
 Strada residenziale // *Residential street*



Viale pedonale  
*Pedestrian path*

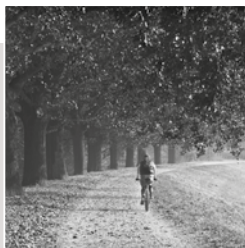

Pista ciclabile  
*Cycle path*



Strada extraurbana  
*Suburban street*

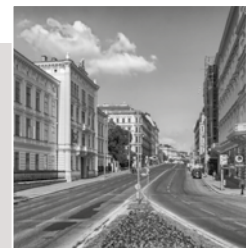

Strada urbana  
*Urban street*



Strada residenziale  
*Residential street*

## OPTIC Type 4



Type 4

**Applicazioni // Applications:**

Attraversamento pedonale //

*Pedestrian crossings*

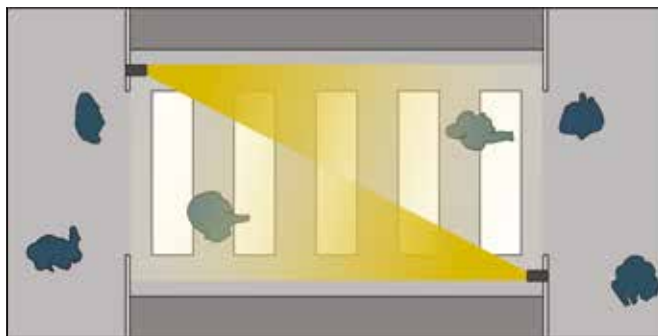

Distribuzione luminosa asimmetrica.

Ottica idonea per l'installazione su attraversamenti pedonali.

*Asymmetric luminous distribution.*

*Optic type suited for installation on pedestrian crossings.*

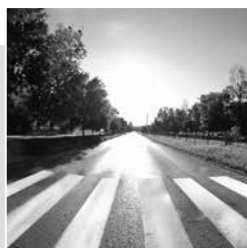

Attraversamento pedonale

*Pedestrian crossings*

## OPTIC Type 5 / Type R5



Type 5



Type R5

### Applicazioni // Applications:

Piazza // Square

Parco // Park

Viale pedonale // Pedestrian path

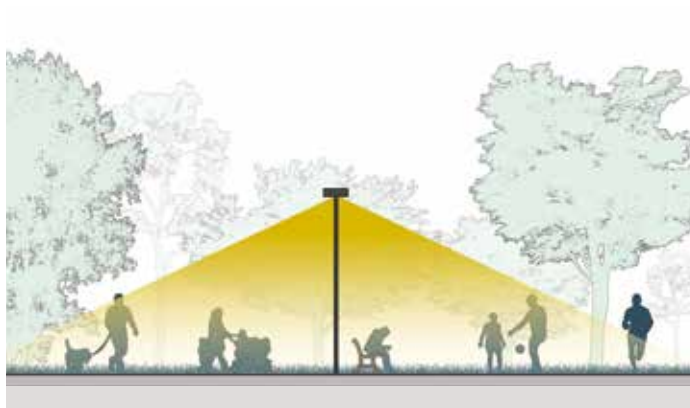

Distribuzione luminosa a simmetria rotazionale.  
Ottica idonea per l'installazione in grandi aree,  
piazze, parchi e parcheggi.

*Rotationally symmetric light distribution.  
Optic type designed to suit parks, squares,  
parking lots and other large surfaces.*



Piazza  
Square



Parco  
Park



Viale pedonale  
Pedestrian path

Reflexa **R**



## OPTIC Type COMBO



Type Combo



Combo è una soluzione illuminotecnica flessibile, ottenuta dalla combinazione delle tipologie di ottiche precedenti (1-2-3-4-5). Combo viene studiata per rispondere alle esigenze dell'installazione specifica.

*Combo is a flexible lighting solution achieved by a combination of previously mentioned optics (1-2-3-4-5). Combo is designed to meet specific installation requirements.*

## OPTIC Type Architectural

Distribuzioni varie per applicazioni architeturali.  
*Various light distributions for architectural applications.*



6 180°



6 360°

**Applicazioni // Applications:**  
Viale pedonale // Pedestrian path  
Parco // Park



7

**Applicazioni // Applications:**  
A muro // Wall-mounted



8

**Applicazioni // Applications:**  
A proiezione // Projected

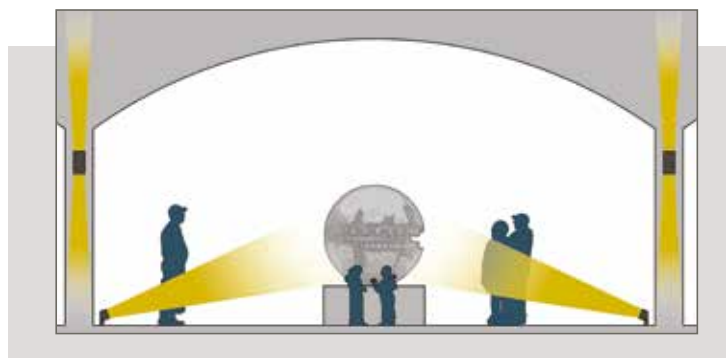
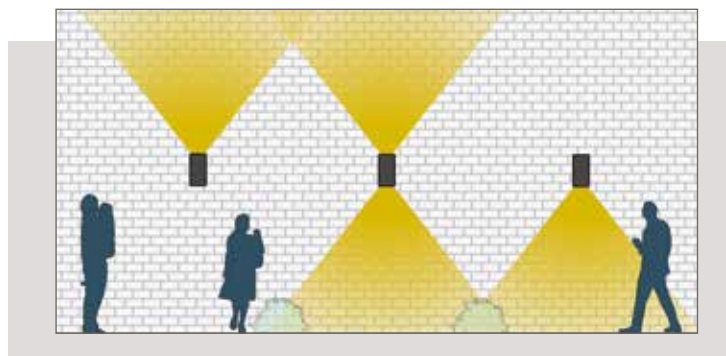
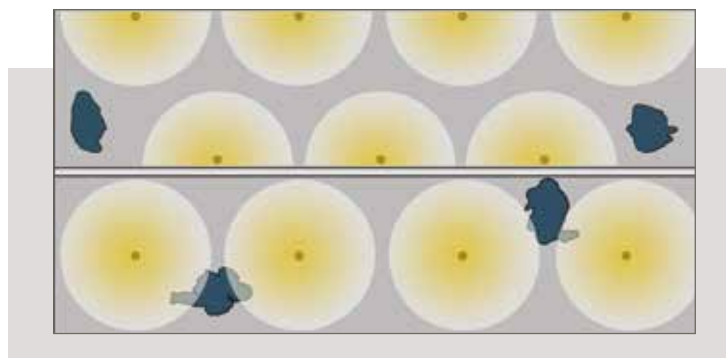

## OPTIC Type Floodlights

Distribuzioni varie per proiezioni.  
*Various light distributions for floodlights.*



9



R9



10



R10



11



R11

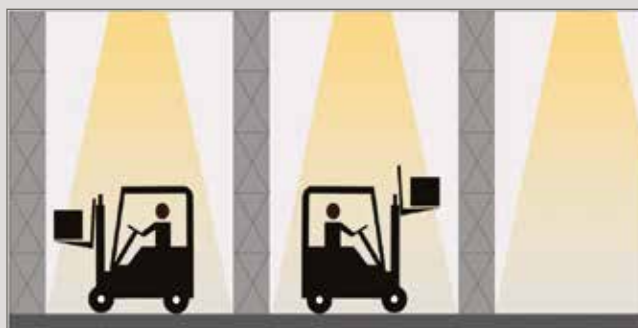
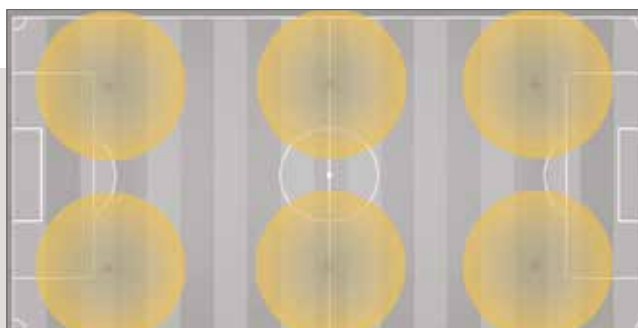

### Applicazioni // Applications:

Stadi // Stadiums

Aree sportive // Sport areas

Aree industriali // Industrial areas

Torrefaro // High-mast lighting

Parcheggi // Car parks

**Reflexa** 



**Illuminazione stradale //**  
*street lighting*

**CORPI ILLUMINANTI // *lighting fixtures***

36 **IZAR 400**

38 **IZAR 500**

**PALI // *poles***

42 **IZAR RING POLE**

48 **IZAR EDGE POLE**

**MENSOLE A MURO // *wall brackets***

44 **IZAR RING WALL BRACKET**

52 **IZAR EDGE WALL BRACKET**



---

# Izar

Design: Ing. Arch. Paolo Ceredi, Arch. Francesco Ceredi

Linee futuribili che rievocano la navigazione degli spazi siderali.

Un sistema smart di ottiche interscambiabili per soddisfare le esigenze illuminotecniche del contemporaneo.

*Futuristic lines inspired by sidereal space travel. A smart system with interchangeable modules, to meet every contemporary lighting need.*



**IZAR 400**

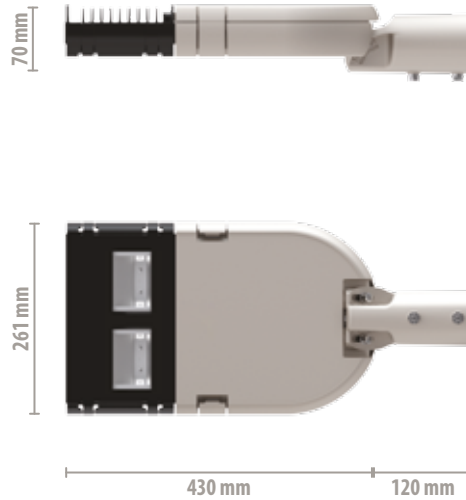

**IZ4  
REFLEXA**

**Specifiche Tecniche // Technical Features**

<b>MATERIALE:</b>	<b>MATERIAL:</b>	<b>TIMELESS</b>
pressofusione di alluminio, vetro.	die-cast aluminium, glass.	Apparecchio apribile e rigenerabile (componentistica interna sostituibile) senza utilizzo di utensili. <i>Tool-free openable fixture - Replaceable internal components without the need of tools.</i>
<b>TEMPERATURA DI COLORE // COLOUR TEMPERATURE</b>		<b>TIPO DI FISSAGGIO // FIXING TYPE</b>
3000K // 4000K // 5700K		
<b>DIMMERABILE // DIMMABLE</b>		<b>TESTA-PALO // POLE-TOP</b>
<b>SISTEMI OTTICI // OPTICAL SYSTEMS</b>		<b>LATERALE // SIDE</b>
<p>• TYPE R2 •    • TYPE R3 •</p>		<p>Regolabile con step da 5° <i>Adjustable with 5° steps</i></p> <p>Regolabile con step da 5° <i>Adjustable with 5° steps</i></p> <p>+20°                      +10° -20°                      -20°</p>

Corpo illuminante con vano LED separato dal vano driver // Light fixture with the LED unit separated from the driver case

Per maggiori informazioni vedi scheda tecnica prodotto // For more information see our product datasheet





**IZAR 500**

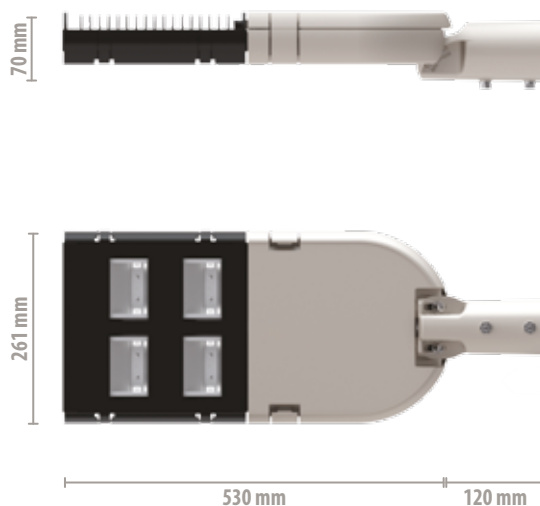

**IZ5  
REFLEXA**

**Specifiche Tecniche // Technical Features**

<p><b>MATERIALE:</b> pressofusione di alluminio, vetro.</p>	<p><b>MATERIAL:</b> die-cast aluminium, glass.</p>	<p><b>TIMELESS</b> Apparecchio apribile e rigenerabile (componentistica interna sostituibile) senza utilizzo di utensili. <i>Tool-free openable fixture - Replaceable internal components without the need of tools.</i></p>		
<p><b>TEMPERATURA DI COLORE // COLOUR TEMPERATURE</b> 3000K // 4000K // 5700K</p>		<p><b>TIPO DI FISSAGGIO // FIXING TYPE</b></p>		
<p><b>DIMMERABILE // DIMMABLE</b></p>		<div style="display: flex; justify-content: space-around;"> <div data-bbox="810 1499 1050 1669"> </div> <div data-bbox="1050 1499 1286 1669"> </div> </div>		
<p><b>SISTEMI OTTICI // OPTICAL SYSTEMS</b></p>		<table border="1"> <tr> <td data-bbox="810 1669 1050 1806"> <p><b>TESTA-PALO // POLE-TOP</b> Regolabile con step da 5° <i>Adjustable with 5° steps</i></p> </td> <td data-bbox="1050 1669 1286 1806"> <p><b>LATERALE // SIDE</b> Regolabile con step da 5° <i>Adjustable with 5° steps</i></p> </td> </tr> </table>	<p><b>TESTA-PALO // POLE-TOP</b> Regolabile con step da 5° <i>Adjustable with 5° steps</i></p>	<p><b>LATERALE // SIDE</b> Regolabile con step da 5° <i>Adjustable with 5° steps</i></p>
<p><b>TESTA-PALO // POLE-TOP</b> Regolabile con step da 5° <i>Adjustable with 5° steps</i></p>	<p><b>LATERALE // SIDE</b> Regolabile con step da 5° <i>Adjustable with 5° steps</i></p>			
<div style="display: flex; justify-content: space-around;"> <div data-bbox="427 1689 539 1764"> <p>• TYPE R2 •</p> </div> <div data-bbox="555 1689 667 1764"> <p>• TYPE R3 •</p> </div> </div>				

Corpo illuminante con vano LED separato dal vano driver // Light fixture with the LED unit separated from the driver case

Per maggiori informazioni vedi scheda tecnica prodotto // For more information see our product datasheet

**illuminazione stradale // street lighting**









## IZAR RING POLE

Un anello inciso alla base, un anello inciso sulla cima. Questo è "Izar Ring": una collezione di pali minimale, che propone un'esperienza estetica sintetica e rigorosa.

*One carved ring at the bottom and one carved ring at the top. This is "Izar Ring": a minimalist collection of poles that provides a compendious and rigorous aesthetic experience.*

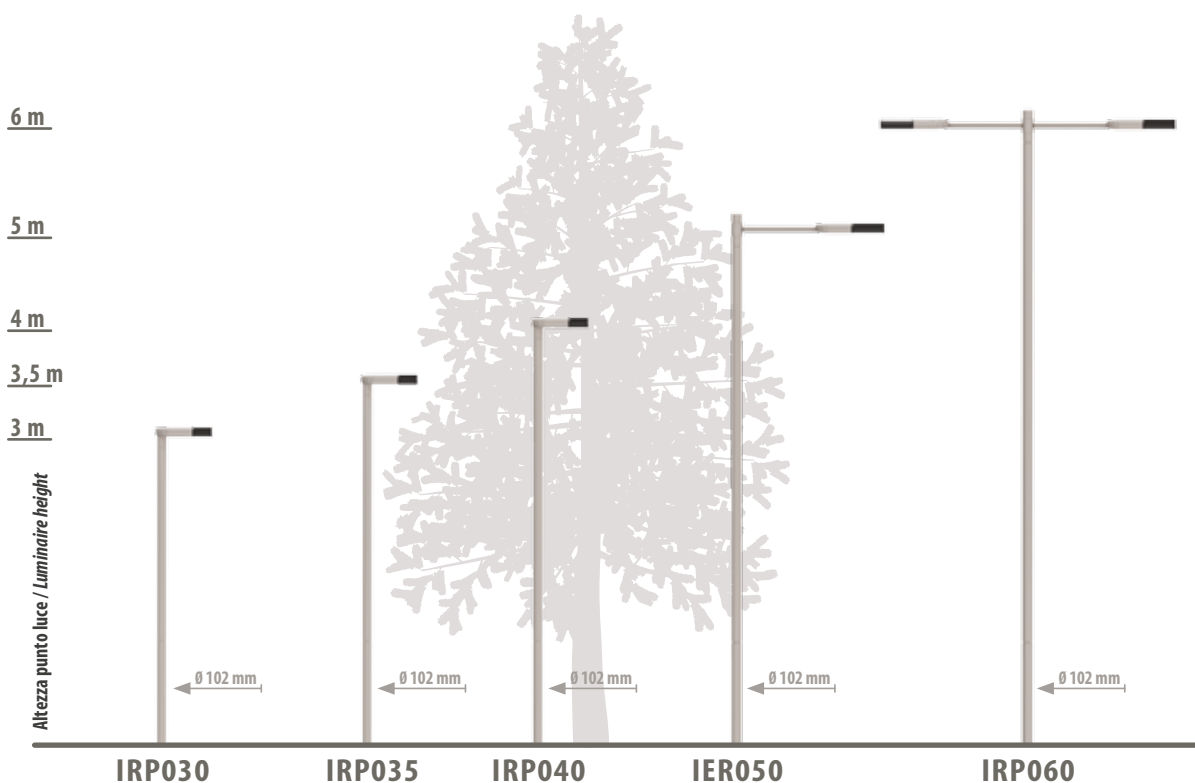

### Versioni Disponibili // Available Versions

IRP050 - IRP060 mensola singola o doppia / IRP050 - IRP060 single or double arm  
 Ogni palo è predisposto per Izar 400 o Izar 500 / All poles can be equipped with Izar 400 or Izar 500  
 Tipo di fissaggio: flangia o fondazione / Fixing type: flange or foundation

### Sbraccio // Extension

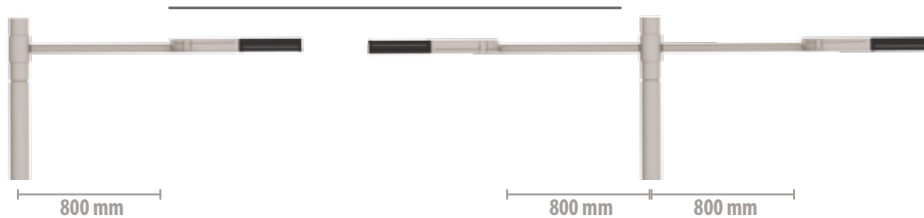

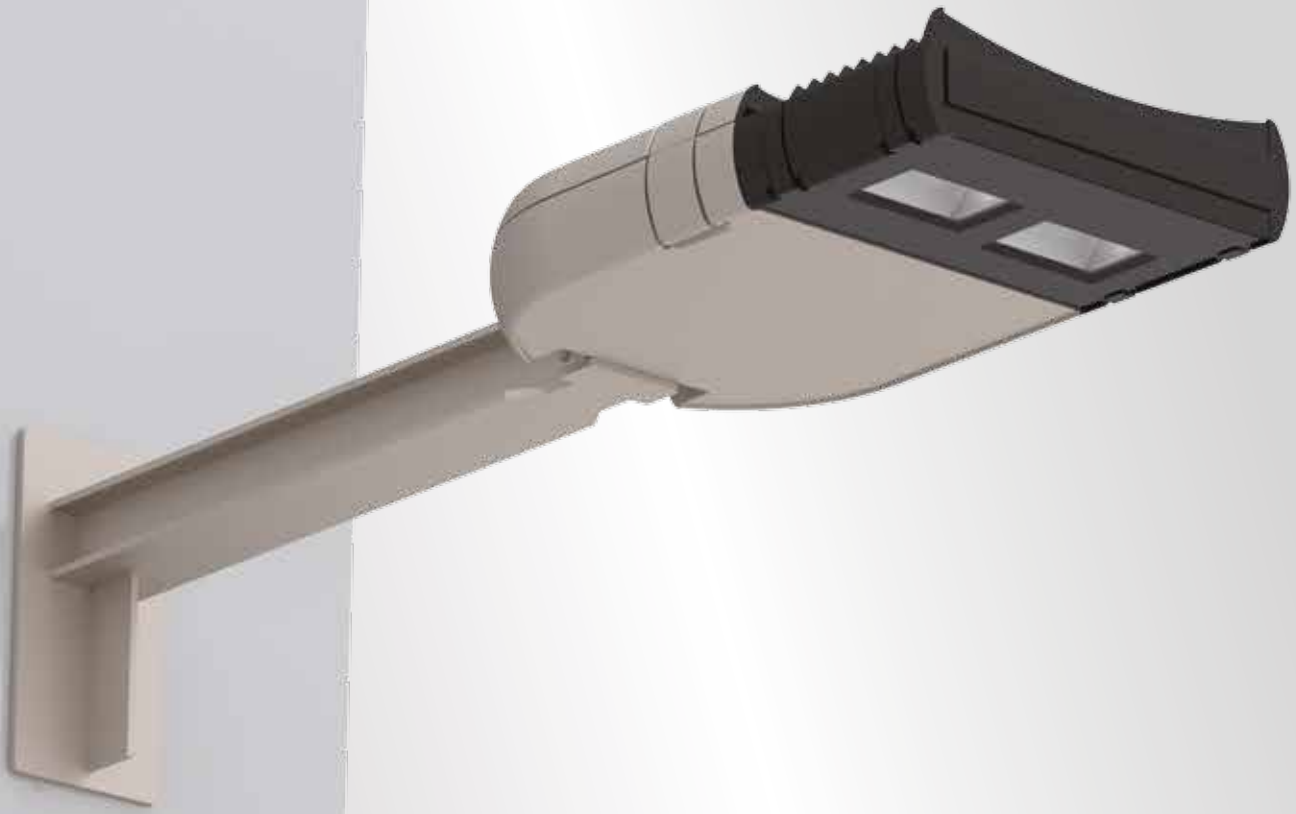

## IZAR RING WALL BRACKET

La mensola a muro "Izar Ring" esibisce componenti tipici della carpenteria metallica come piastre e fazzoletti, modellandoli con armonia ed eleganza. Disponibile in un'unica versione per il corpo illuminante Izar 400.

*"Izar Ring" Wall Bracket includes typical sheet metal parts like support plates and gussets. It is shaped to create an elegant and harmonious style. Available in only one version suitable for Izar 400.*

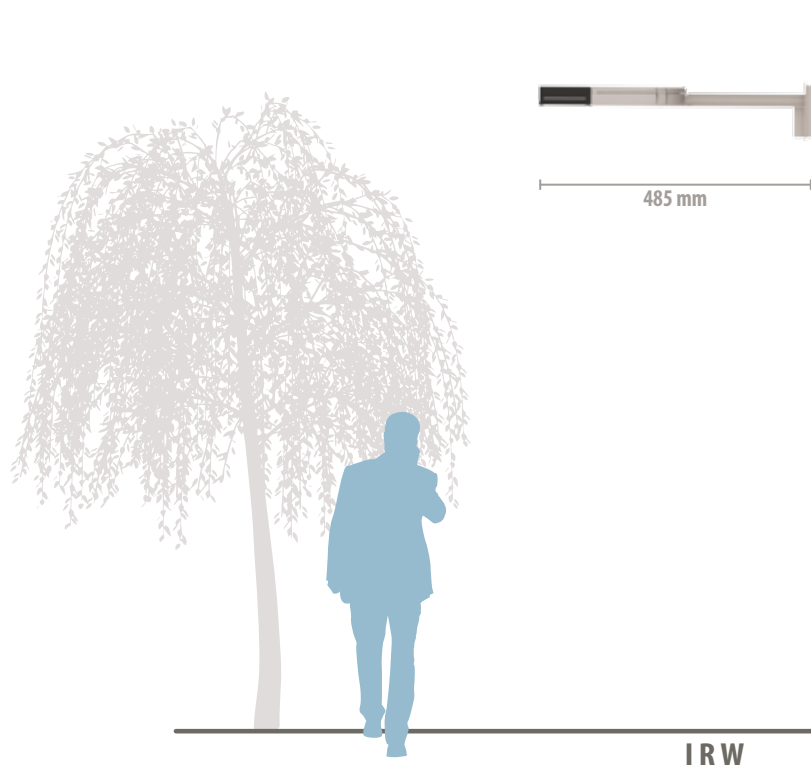

**illuminazione stradale // street lighting**









## IZAR EDGE POLE

Il bordo segna l'allargarsi del palo a terra, il bordo marca l'attacco del corpo illuminato in cima. "Izar Edge" esprime la sua essenza nel bordo, nel confine dei suoi componenti e nell'espressività tecnica degli sbracci.

*The edge marks the widening pole base on the ground. The edge marks the lighting fixture attachment at the top. "Izar Edge" expresses its essence in the edge, in the border of its components and in the technical expressiveness of poles and brackets.*

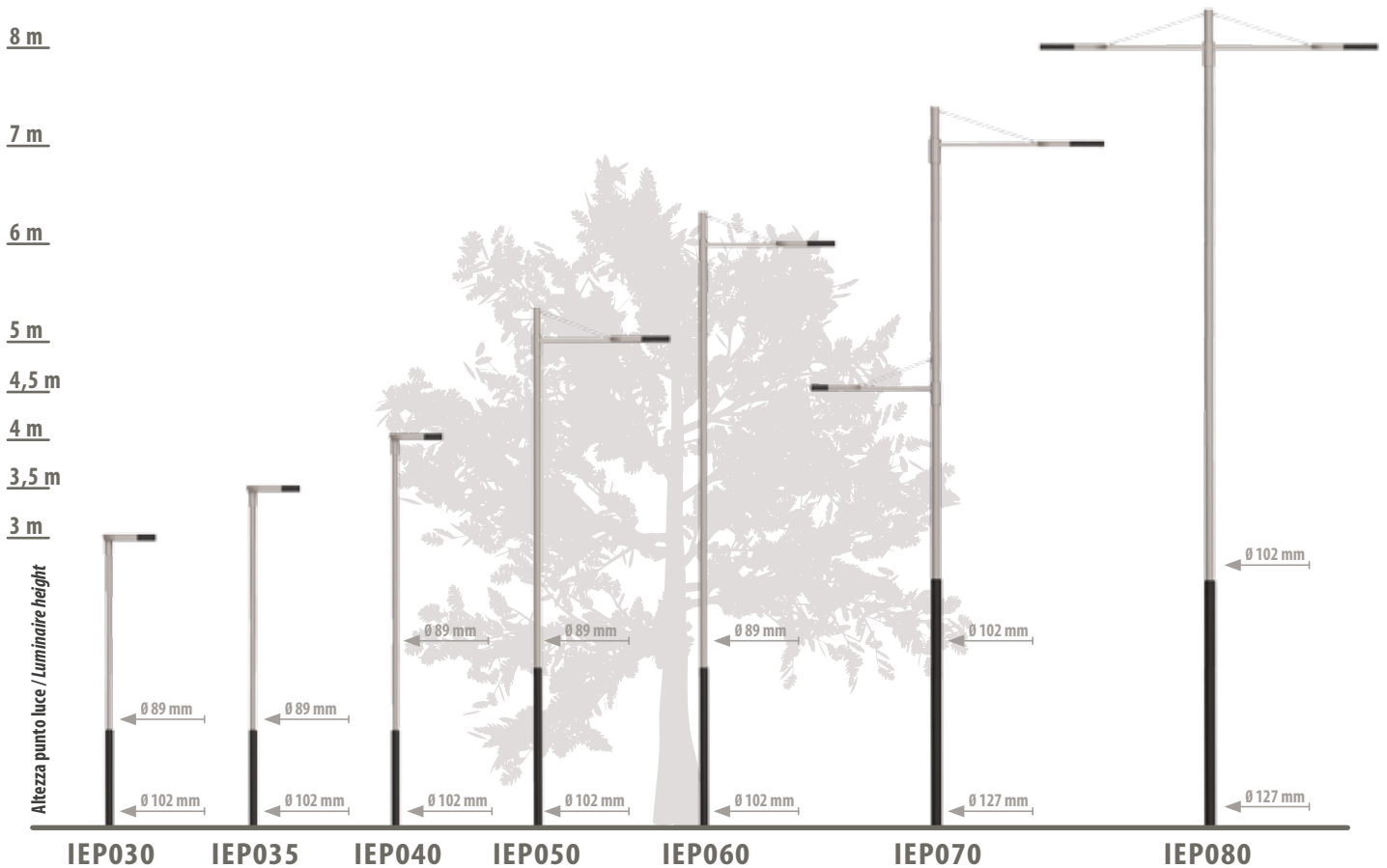

### Versioni Disponibili // Available Versions

IEP050 mensola singola o doppia / IEP050 single or double arm

IEP060 - IEP070 - IEP080 mensola singola, doppia o sfalsata / IEP060 - IEP070 - IEP080 single, double or split-level arm

Ogni palo è predisposto per Izar 400 o Izar 500 / All poles can be equipped with Izar 400 or Izar 500

Tipo di fissaggio: flangia o fondazione / Fixing type: flange or foundation

### Sbraccio // Extension

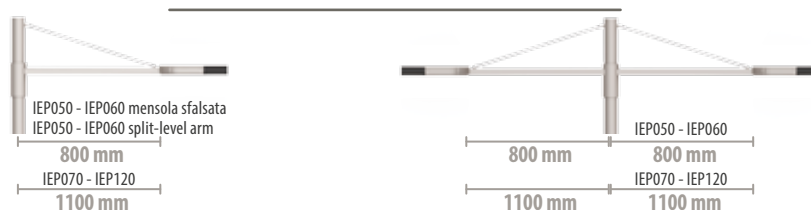



**IZAR EDGE POLE**

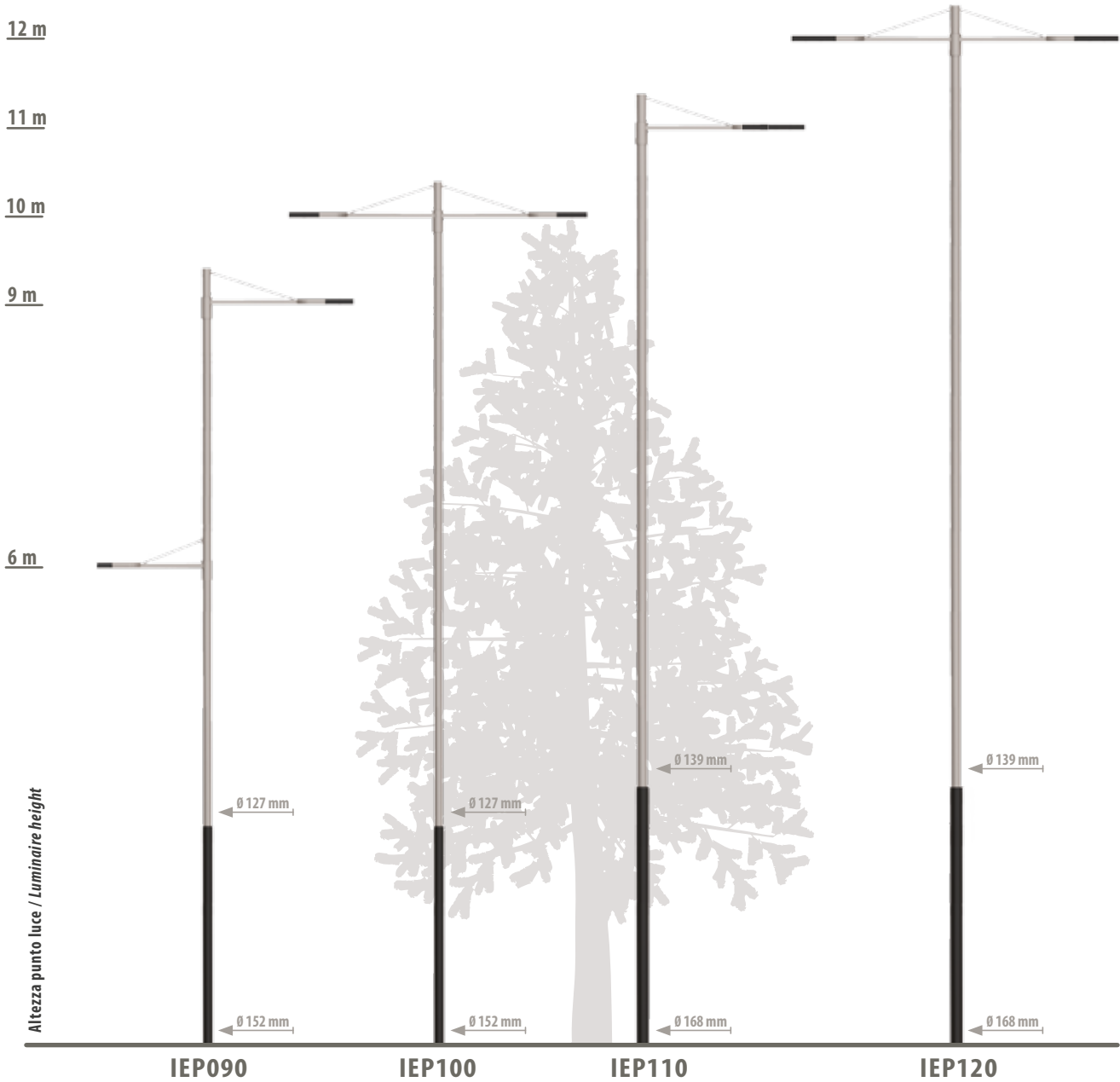

**Versioni Disponibili // Available Versions**

IEP090 - IEP100 - IEP110 - IEP120 mensola singola, doppia o sfalsata / IEP090 - IEP100 - IEP110 - IEP120 single, double or split-level arm

Pali predisposti per Izar 400 o Izar 500 / Can be equipped with Izar 400 or Izar 500

Tipo di fissaggio: flangia o fondazione / Fixing type: flange or foundation





## IZAR EDGE WALL BRACKET

Una mensola forata da un'asola con le estremità smussate si innesta su una piastra a muro dai bordi rotondeggianti. Il paradigma della semicirconferenza trabocca dal corpo illuminante al suo sbraccio. Disponibile in un'unica versione per il corpo illuminante Izar 400.

*A bracket pierced by a slot with chamfered ends fits into a wall plate with rounded edges. The semicircle paradigm characterizing the lighting fixture is recalled by its bracket extension. Available in only one version suitable for Izar 400.*

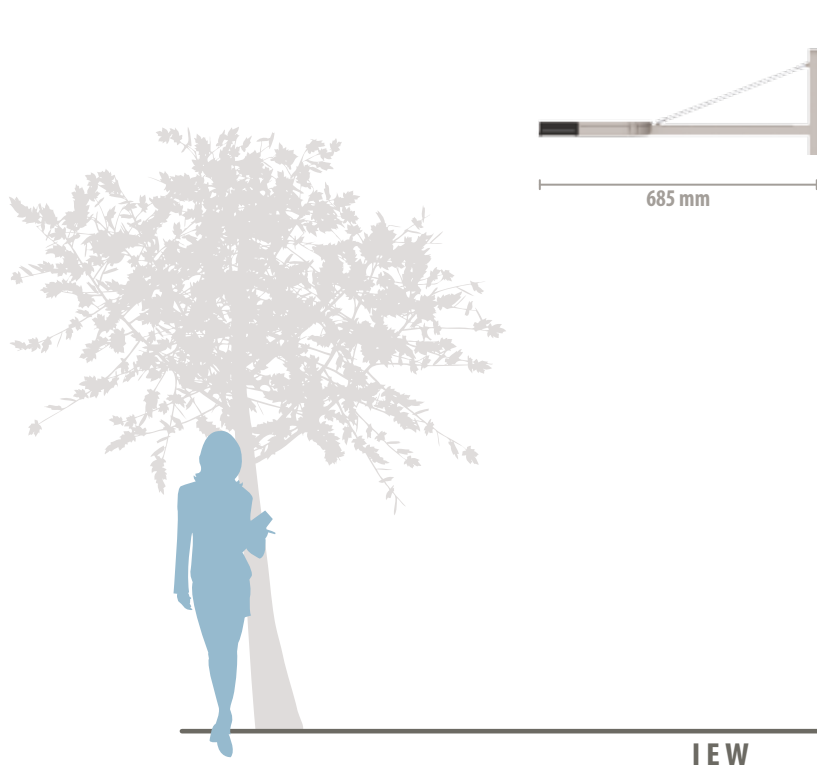

**illuminazione stradale // street lighting**







**Illuminazione stradale //**  
*street lighting*

**CORPI ILLUMINANTI // *lighting fixtures***

58 **LAFGLIA** SMALL

60 **LAFGLIA** MEDIUM

62 **LAFGLIA** LARGE

**PALI // *poles***

66 **LAFGLIA** POLE

**MENSOLE A MURO // *wall brackets***

70 **LAFGLIA** WALL BRACKET



---

# la Foglia

Design: Ing. Arch. Paolo Ceredi, Arch. Francesco Ceredi

Sottile e rotonda come una foglia. Un disegno essenziale e compatto. Un sistema versatile e tecnologico per affrontare le sfide dello spazio urbano contemporaneo.

*Round and thin as a leaf. Essential compact design. The versatile technological system of laFoglia can face the challenges of urban contemporary spaces.*



**L AFOGLIA SMALL**

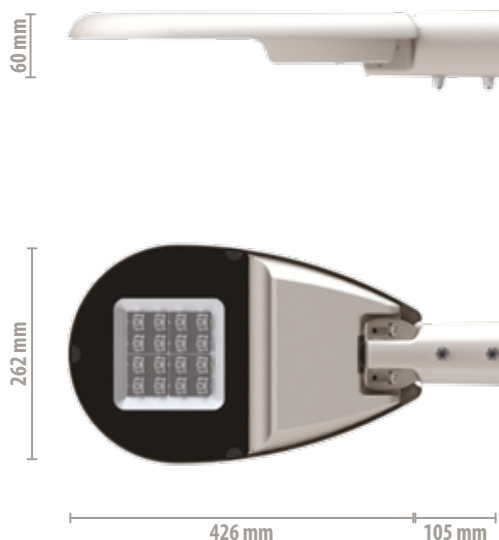

**LFS  
GLASSED**

**Specifiche Tecniche // Technical Features**

<p><b>MATERIALE:</b> pressofusione di alluminio, vetro.</p>	<p><b>MATERIAL:</b> die-cast aluminium, glass.</p>	<p><b>COMPACT</b> Apparecchio sigillato, fornito con connettore rapido per installazione immediata. <i>Sealed fixture with short power cable and IP electrical connector for a quick and simple linkage to the mains.</i></p>		
<p><b>TEMPERATURA DI COLORE // COLOUR TEMPERATURE</b> 3000K // 4000K // 5700K</p>		<p><b>TIPO DI FISSAGGIO // FIXING TYPE</b></p>		
<p><b>DIMMERABILE // DIMMABLE</b></p>				
<p><b>SISTEMI OTTICI // OPTICAL SYSTEMS</b></p>		<table border="1"> <tr> <td data-bbox="815 1675 1050 1804"> <p><b>TESTA-PALO // POLE-TOP</b> Regolabile con step da 5° <i>Adjustable with 5° steps</i></p> <p>+15°</p> </td> <td data-bbox="1050 1675 1286 1804"> <p><b>LATERALE // SIDE</b> Regolabile con step da 5° <i>Adjustable with 5° steps</i></p> <p>+5° -15°</p> </td> </tr> </table>	<p><b>TESTA-PALO // POLE-TOP</b> Regolabile con step da 5° <i>Adjustable with 5° steps</i></p> <p>+15°</p>	<p><b>LATERALE // SIDE</b> Regolabile con step da 5° <i>Adjustable with 5° steps</i></p> <p>+5° -15°</p>
<p><b>TESTA-PALO // POLE-TOP</b> Regolabile con step da 5° <i>Adjustable with 5° steps</i></p> <p>+15°</p>	<p><b>LATERALE // SIDE</b> Regolabile con step da 5° <i>Adjustable with 5° steps</i></p> <p>+5° -15°</p>			
<p>• TYPE 2 •    • TYPE 3 •    • TYPE 4 •</p>				



**LAFOGLIA MEDIUM**

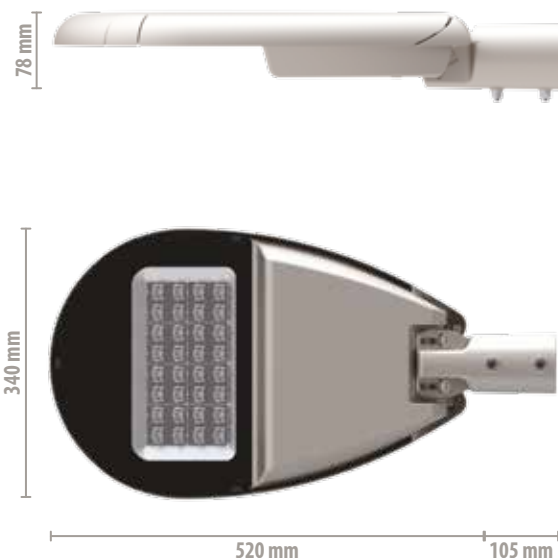

**LFM  
GLASSED**

**Specifiche Tecniche // Technical Features**

<b>MATERIALE:</b>	<b>MATERIAL:</b>	<b>TIMELESS</b>
pressofusione di alluminio, vetro.	die-cast aluminium, glass.	Apparecchio apribile e rigenerabile (componentistica interna sostituibile) senza utilizzo di utensili. <i>Tool-free openable fixture - Replaceable internal components without the need of tools.</i>
<b>TEMPERATURA DI COLORE // COLOUR TEMPERATURE</b>		<b>TIPO DI FISSAGGIO // FIXING TYPE</b>
3000K // 4000K // 5700K		
<b>DIMMERABILE // DIMMABLE</b>		<b>TESTA-PALO // POLE-TOP</b>
<b>SISTEMI OTTICI // OPTICAL SYSTEMS</b>		<b>LATERALE // SIDE</b>
<p>• TYPE 2 •    • TYPE 3 •    • TYPE 4 •</p>		<p>Regolabile con step da 5° <i>Adjustable with 5° steps</i></p> <p>+20°</p> <p>Regolabile con step da 5° <i>Adjustable with 5° steps</i></p> <p>+10° -20°</p>





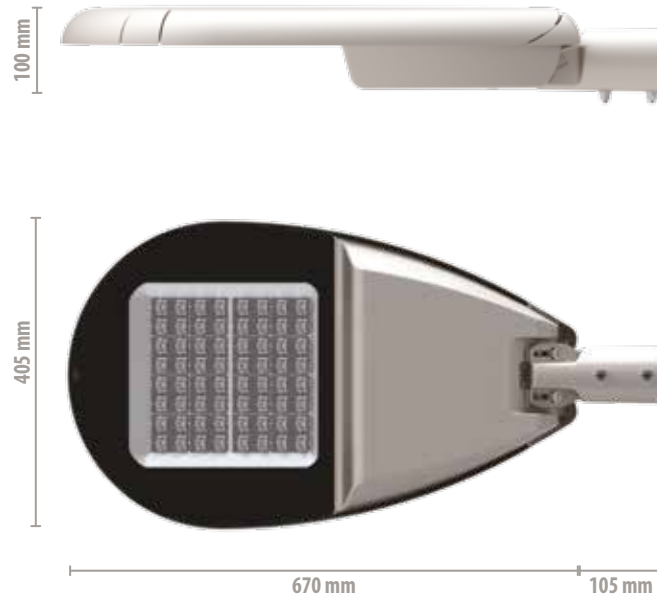

**LAFOGLIA LARGE**

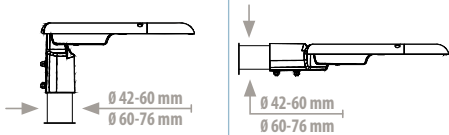

**LFL  
GLASSED**

**Specifiche Tecniche // Technical Features**

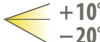
<b>MATERIALE:</b>	<b>MATERIAL:</b>	 <b>TIMELESS</b> Apparecchio apribile e rigenerabile (componentistica interna sostituibile) senza utilizzo di utensili. <i>Tool-free openable fixture - Replaceable internal components without the need of tools.</i>
pressofusione di alluminio, vetro.	die-cast aluminium, glass.	
<b>TEMPERATURA DI COLORE // COLOUR TEMPERATURE</b>		<b>TIPO DI FISSAGGIO // FIXING TYPE</b>
3000K // 4000K // 5700K		
<b>DIMMERABILE // DIMMABLE</b>		<b>TESTA-PALO // POLE-TOP</b>
<b>SISTEMI OTTICI // OPTICAL SYSTEMS</b>		<b>LATERALE // SIDE</b>
 <p>· TYPE 2 ·   · TYPE 3 ·   · TYPE 4 ·</p>		Regolabile con step da 5° <i>Adjustable with 5° steps</i>  +20°
		Regolabile con step da 5° <i>Adjustable with 5° steps</i>  +10° -20°

**illuminazione stradale // street lighting**











## L A F O G L I A P O L E

“laFoglia” è una collezione di pali elegante dal disegno asciutto, nata per illuminare la città nelle sue infinite declinazioni. L'affusolata rotondità del corpo illuminante laFoglia si combina con la slanciata preziosità di un palo conico laminato senza saldature. La cima è marcata da una fuga leggera che segna il confine di una bicromia sorprendente.

*“laFoglia” is an elegant collection with a lean design, created to illuminate the city in its infinite variations. The streamlined circular body of laFoglia is combined with the slender preciousness of a rolled conical pole without welding. The top is marked by a soft break that highlights the boundary of an amazing dual tone finish.*

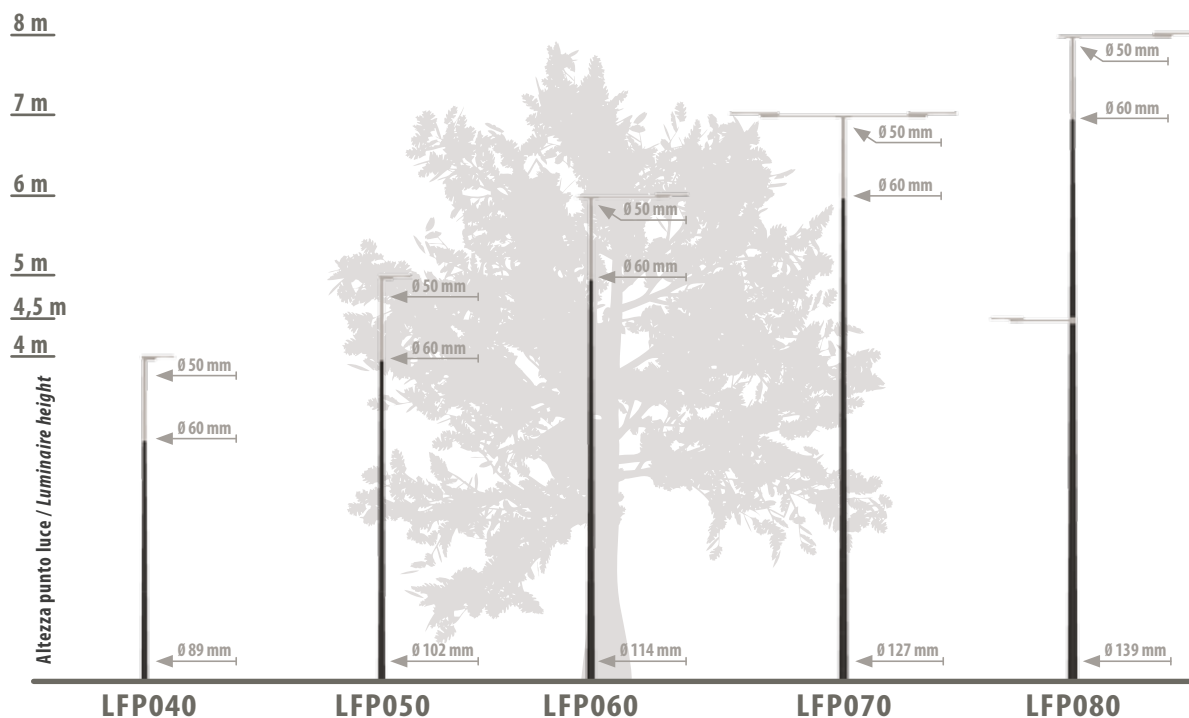

### Versioni Disponibili // Available Versions

LFP060 - LFP070 - LFP080 mensola singola, doppia o sfalsata / LFP060 - LFP070 - LFP080 single, double or split-level arm  
 Ogni palo è predisposto per laFoglia SMALL, MEDIUM o LARGE / All poles can be equipped with laFoglia SMALL, MEDIUM or LARGE

Tipo di fissaggio: flangia o fondazione / Fixing type: flange or foundation

### Sbraccio // Extension

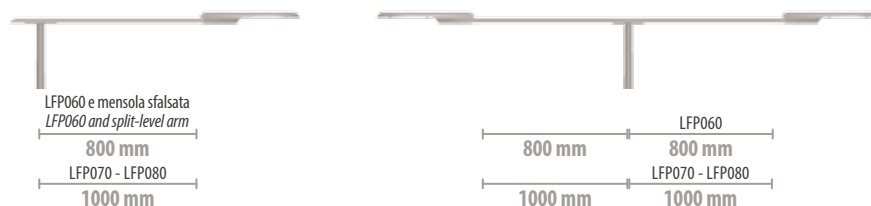



**LAFOGLIA POLE**

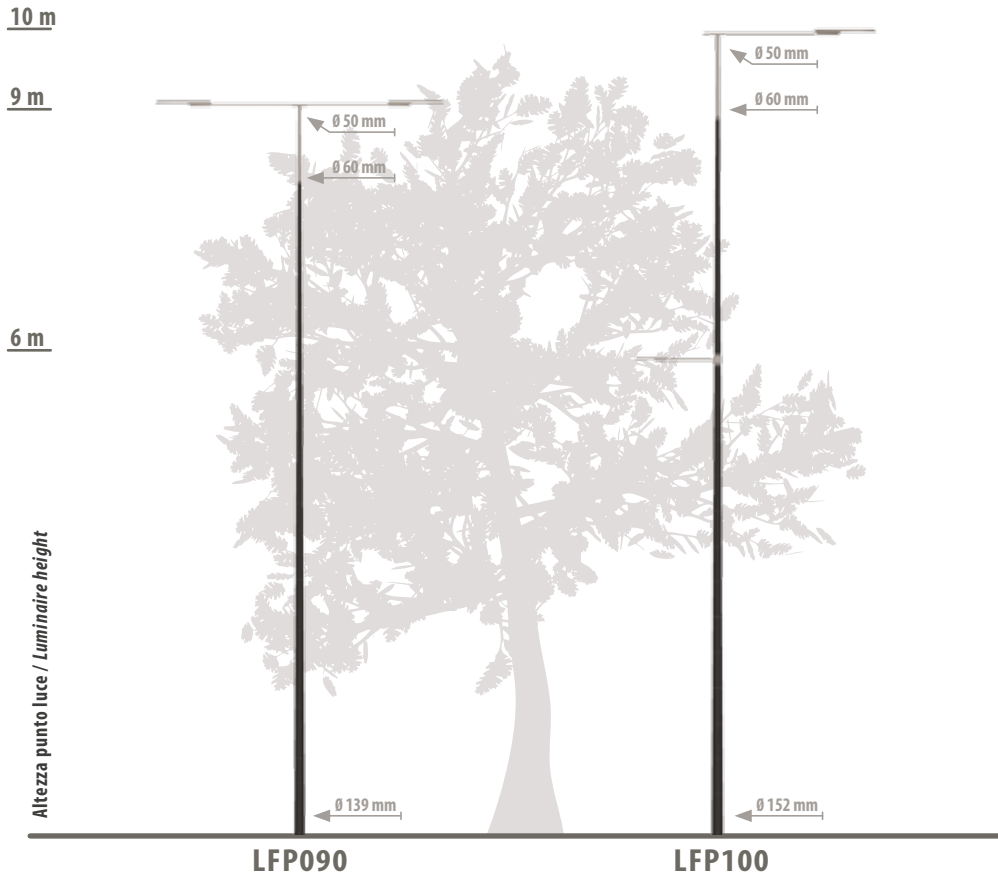

**Versioni Disponibili // Available Versions**

LFP090 - LFP100 mensola singola, doppia o sfalsata / LFP090 - LFP100 single, double or split-level arm  
 Ogni palo è predisposto per laFoglia SMALL, MEDIUM o LARGE / All poles can be equipped with laFoglia SMALL, MEDIUM or LARGE  
 Tipo di fissaggio: flangia o fondazione / Fixing type: flange or foundation

**Sbraccio // Extension**

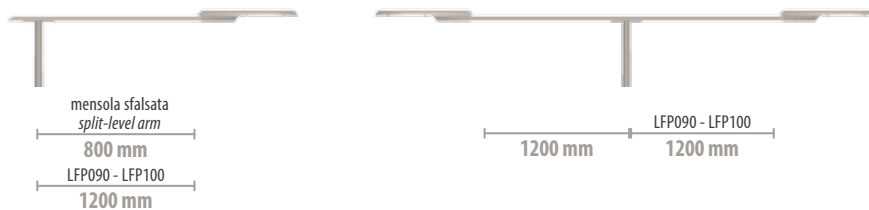



## LAFOGLIA WALL BRACKET

La mensola a muro “laFoglia” completa la gamma di pali, riprendendone le forme ed il design. Disponibile in un’unica versione per sostenere il corpo illuminante laFoglia SMALL e MEDIUM.

*“laFoglia” wall bracket completes the pole range with a coordinated shape and design. Available in only one version suitable for laFoglia SMALL and MEDIUM lighting fixture.*

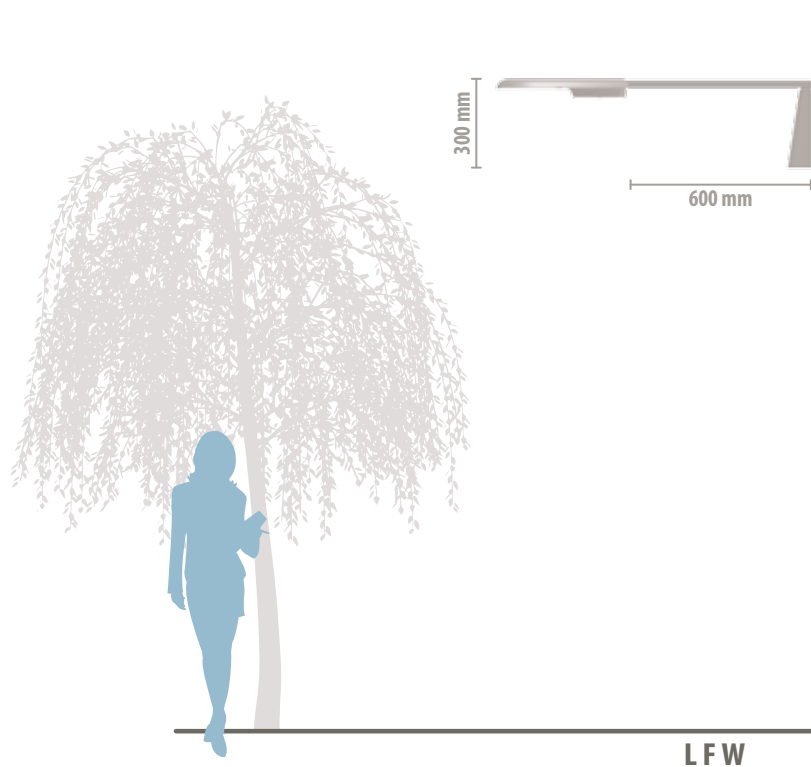



**Illuminazione stradale // street lighting**







**illuminazione stradale //**  
*street lighting*

**CORPI ILLUMINANTI // lighting fixtures**

76

**RONDÒ**

**PALI // poles**

78

**RONDÒ POLE**

88

**RONDÒ ONE POLE**

92

**RONDÒ TRIS POLE**

**TOTEM // totems**

82

**RONDÒ QUADRO TOTEM**

84

**RONDÒ CONO TOTEM**

---

# Rondò

La sua forma armonica e la pluralità delle soluzioni compositive sono la nostra risposta alle esigenze di illuminazione delle nascenti superfici urbane.

*The harmonious shape and the wide range of solutions work together to fit perfectly the lighting needs of any newly designed urban areas.*







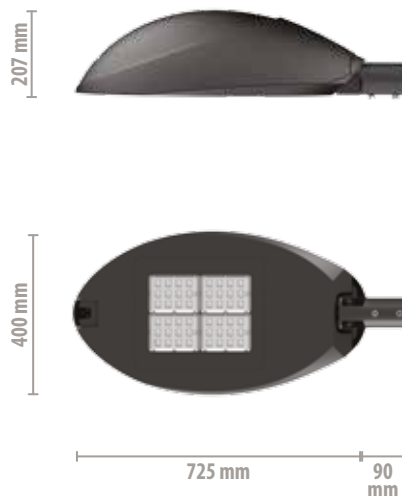

**RONDÒ**

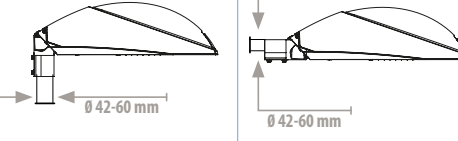

**RON  
GLASS-FREE**

**Specifiche Tecniche // Technical Features**

<b>MATERIALE:</b>	<b>MATERIAL:</b>	 <b>TIMELESS</b> Apparecchio apribile e rigenerabile (componentistica interna sostituibile) senza utilizzo di utensili. <i>Tool-free openable fixture - Replaceable internal components without the need of tools.</i>
pressofusione di alluminio.	die-cast aluminium.	
<b>TEMPERATURA DI COLORE // COLOUR TEMPERATURE</b>		<b>TIPO DI FISSAGGIO // FIXING TYPE</b>
2200K // 3000K // 4000K // 5700K		
<b>DIMMERABILE // DIMMABLE</b>		<b>TESTA-PALO // POLE-TOP</b>
<b>SISTEMI OTTICI // OPTICAL SYSTEMS</b>		<b>LATERALE // SIDE</b>
 <p>• TYPE 2 •    • TYPE 3 •    • TYPE 5 •</p>		Regolabile con step da 3° <i>Adjustable with 3° steps</i>  +30°
		Regolabile con step da 3° <i>Adjustable with 3° steps</i>  +10° -20°

Disponibile anche nella versione a scarica da 100 a 400 W // Also available in 100 to 400W discharge lamp

Per maggiori informazioni vedi scheda tecnica prodotto // For more information see our product datasheet





## RONDÒ POLE

“Rondò” si distingue per la curvatura ampia ed elegante del fusto conico senza saldature a vista, che permette di valorizzare il profilo stradale in contesti urbani ed extraurbani e che lo rende particolarmente indicato per le rotonde.

*“Rondò” is characterised by a wide and elegant curvature of the conical light pole which improves streets’ appearance in different urban and extra-urban contexts and makes it particularly suitable for roundabouts.*

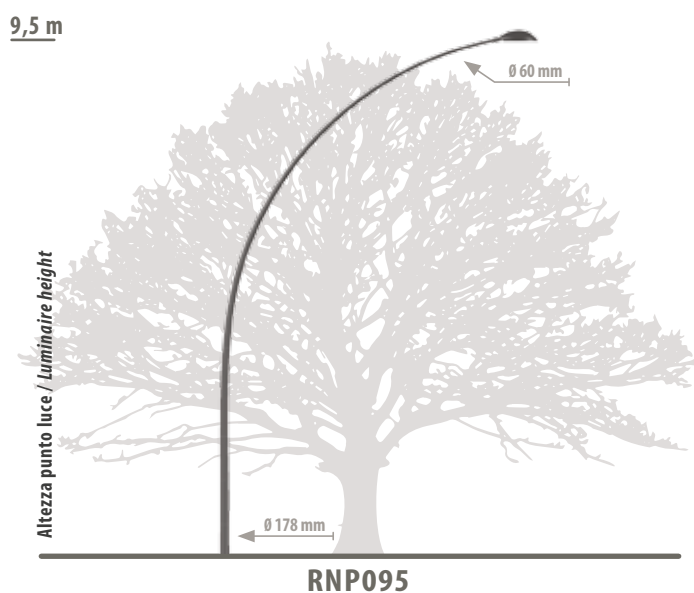

### Versioni Disponibili // Available Versions

Disponibile solo per corpo illuminante Rondò / Only available for Rondò lighting fixture

Tipo di fissaggio: flangia o fondazione / Fixing type: flange or foundation

### Sbraccio // Extension

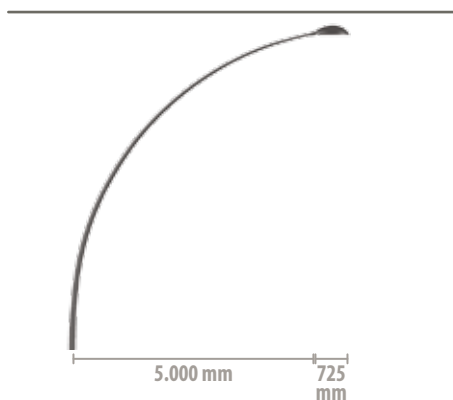

**illuminazione stradale // street lighting**





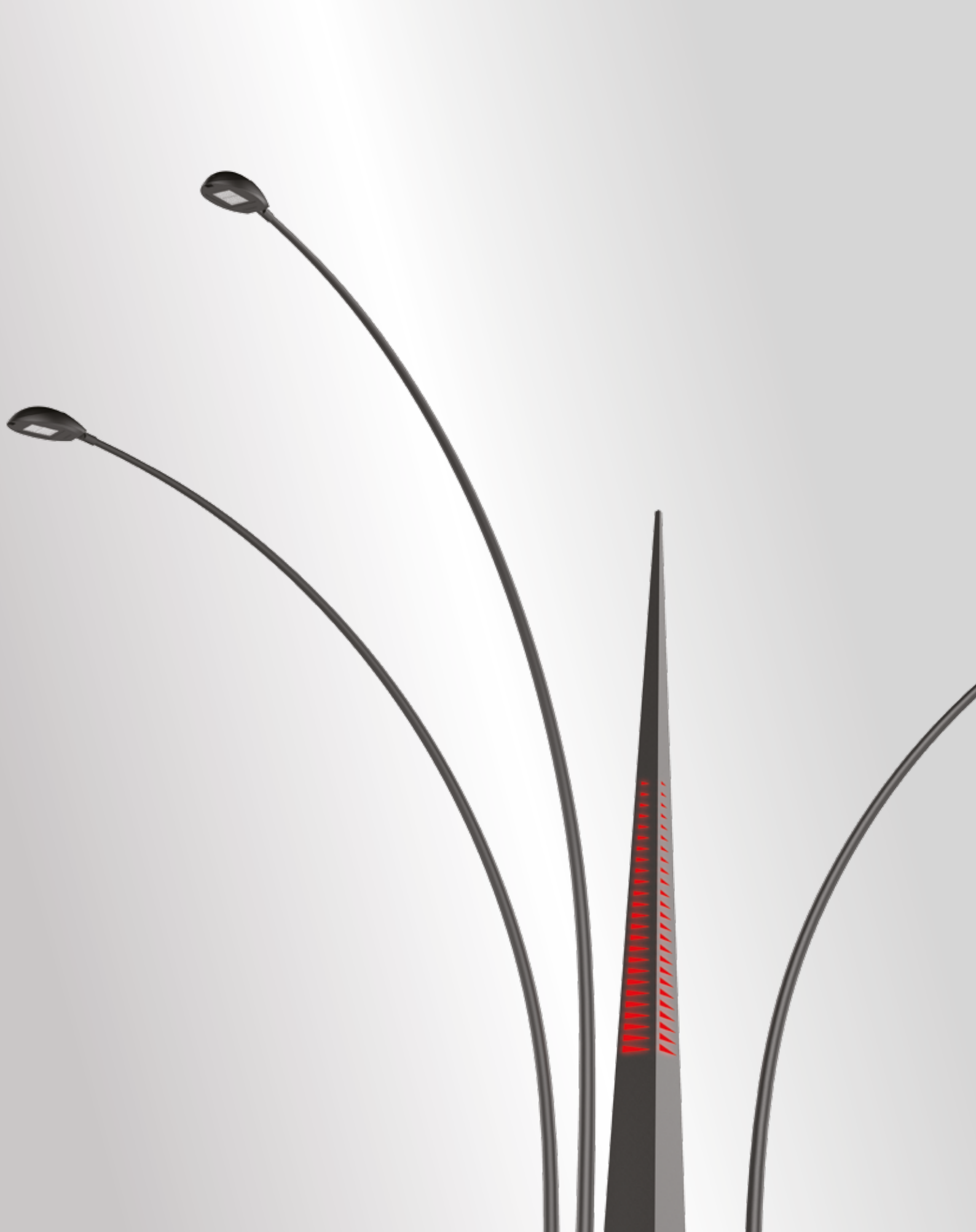

## RONDÒ QUADRO TOTEM

“Rondò Quadro” è un elemento di illuminazione in lamiera di acciaio, disegnato per generare soluzioni di grande impatto visivo, da solo o in abbinamento al palo “Rondò”. Il fusto piramidale si distingue per il decoro retroilluminato a LED, personalizzabile nella forma e nei colori.

*“Rondò Quadro” Totem is a steel sheet lighting element which was designed to have a great visual impact, both as a single element or as a part of “Rondò” Pole collection. Its pyramidal light pole is characterised by a backlit LED decoration which can be customised in shape and colour.*



### **Versioni Disponibili // Available Versions**

Decoro su Totem personalizzabile / Customizable decorative pattern  
 Disponibile nelle varie colorazioni RGB / Available in different RGB colours  
 Tipo di fissaggio: flangia / Fixing type: flange



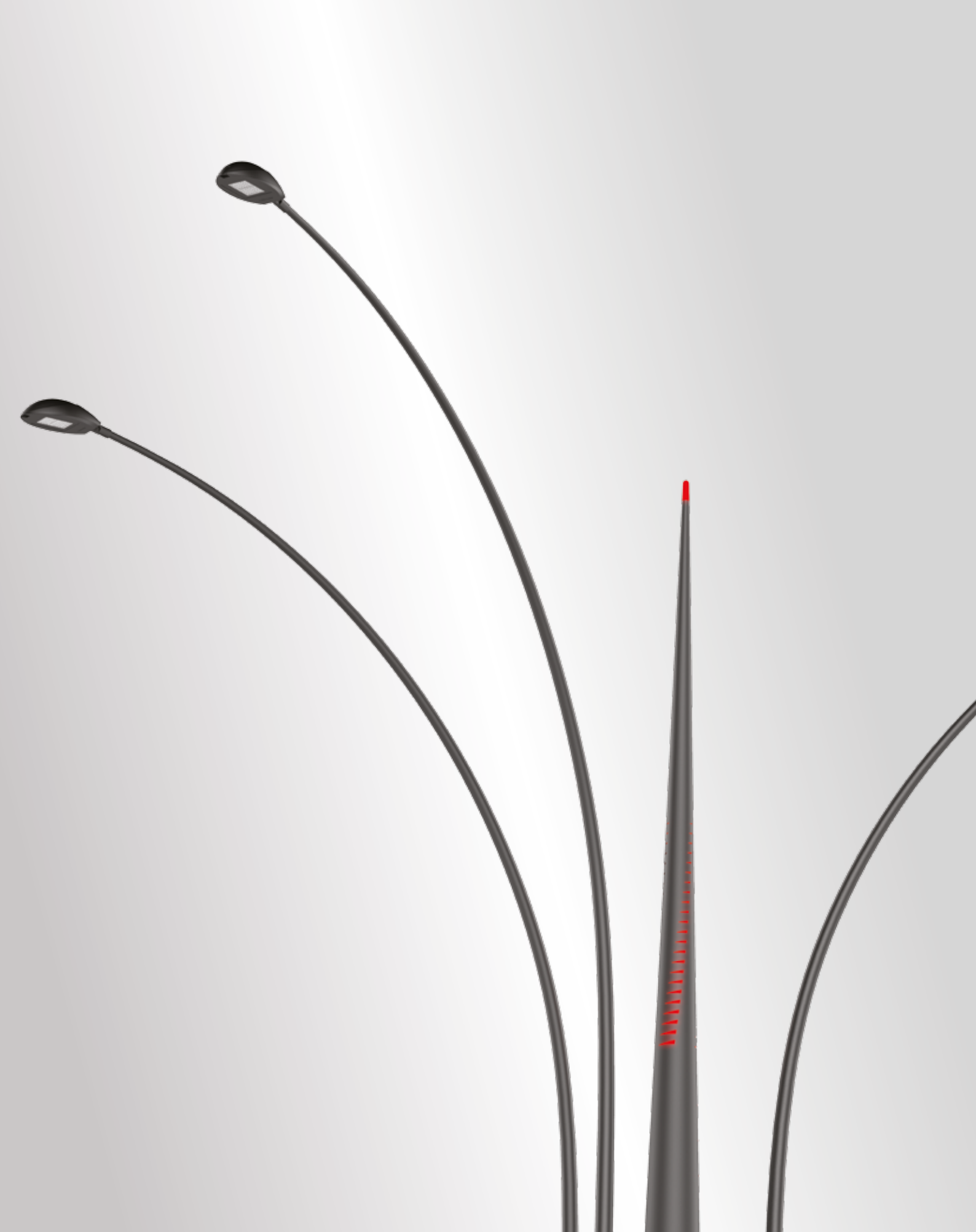

## RONDÒ CONO TOTEM

“Rondò Cono” è un elemento di illuminazione in lamiera di acciaio, disegnato per generare soluzioni di grande impatto visivo, da solo o in abbinamento al palo “Rondò”. Il fusto conico si distingue per il decoro retroilluminato personalizzabile e il puntale, entrambi a LED e disponibili in più varianti di colore.

*“Rondò Cono” is a steel sheet lighting element which was designed to have a great visual impact, both as a single element or as a part of “Rondò” Pole collection. Its conical light pole is characterised by a customisable backlit LED decoration and a LED tip available in different colours.*

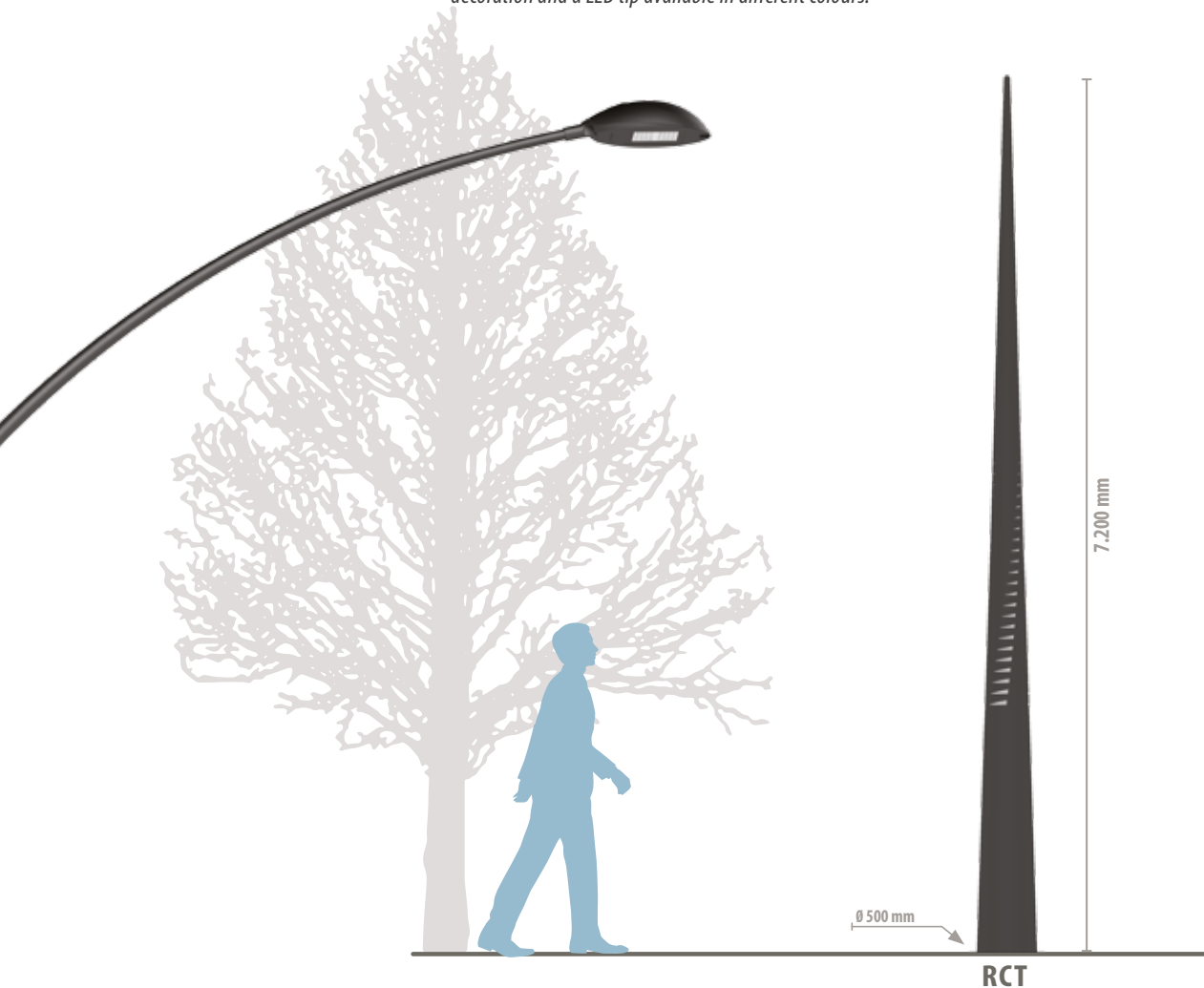

### **Versioni Disponibili // Available Versions**

Decoro su Totem personalizzabile / Customizable decorative pattern  
 Disponibile nelle varie colorazioni RGB / Available in different RGB colours  
 Tipo di fissaggio: flangia / Fixing type: flange

**illuminazione stradale // street lighting**



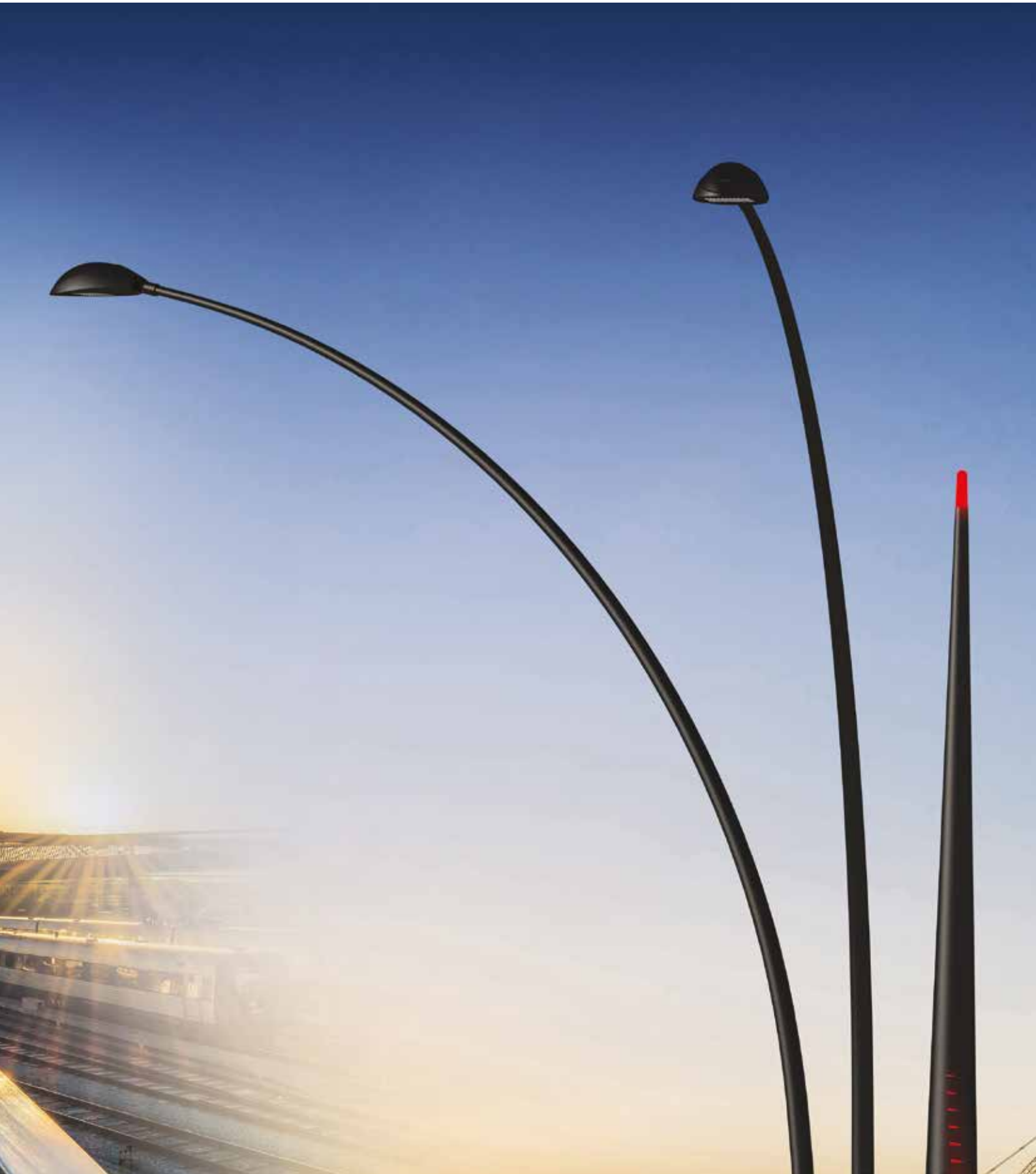



## RONDÒ ONE POLE

“Rondò One” è una serie di pali in acciaio e trafilata di alluminio. L'estetica del fusto e la sinuosità della mensola si combinano alla contemporaneità delle strisce luminose a LED, abbinata agli anelli decorativi sul basamento. La serie è particolarmente indicata per conferire carattere a spazi urbani consolidati o zone extraurbane.

“Rondò One” is a collection of steel and aluminium poles. The design of the pole, together with the curvature of the arm and the LED light strips of the decorative base generate a collection which is particularly suitable for urban or suburban areas.

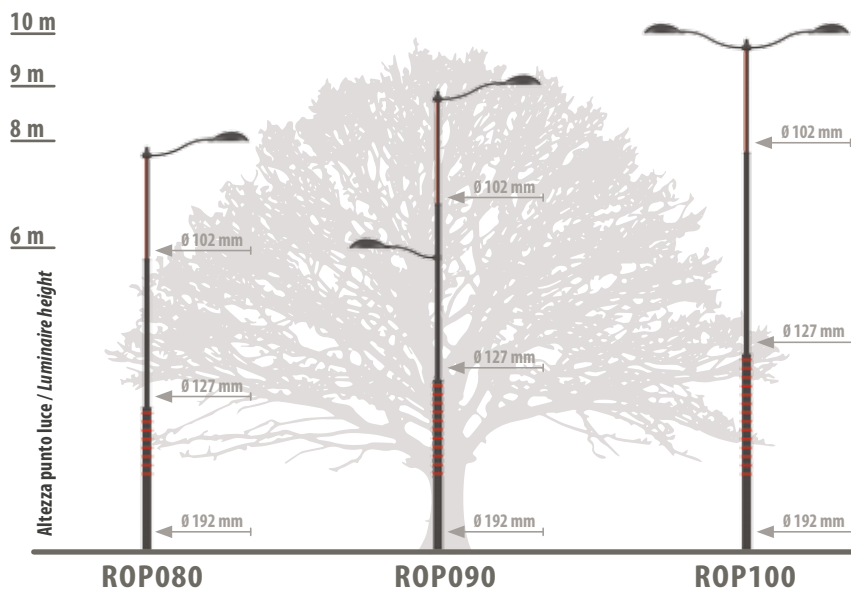

### Versioni Disponibili // Available Versions

ROP080 mensola singola o doppia / ROP080 single or double arm

ROP090 - ROP100 mensola singola, doppia o sfalsata / ROP090 - ROP100 single, double or split-level arm

Strisce luminose a LED e anelli decorativi abbinati fra loro disponibili in rosso, verde, blu o bianco / LED strips and decorative rings available in red, green, blue or white

Tipo di fissaggio: flangia o fondazione / Fixing type: flange or foundation

### Sbraccio // Extension

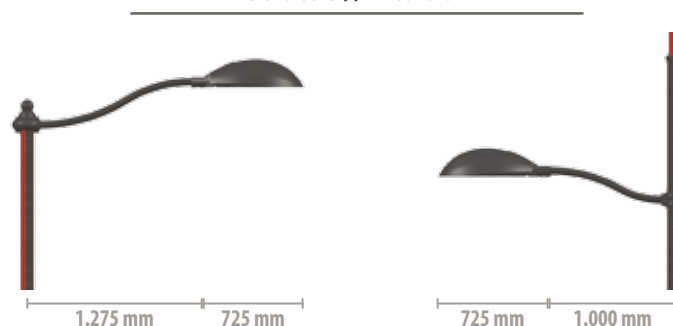



**Illuminazione stradale // street lighting**







## RONDÒ TRIS POLE

“Rondò Tris” è una serie di pali in acciaio e trafilata di alluminio che si distinguono per l'originale geometria del corpo centrale. Le strisce luminose a LED del fusto e gli anelli decorativi del basamento infondono al palo un carattere marcato, capace di valorizzare l'aspetto evocativo e spaziale del contesto.

*“Rondò Tris” is a collection of steel and aluminium poles characterised by the unique design of the central geometry element. The LED light strips on the pole, together with the decorative elements at the base make up a striking design, which is sure to add its own touch to the surroundings.*

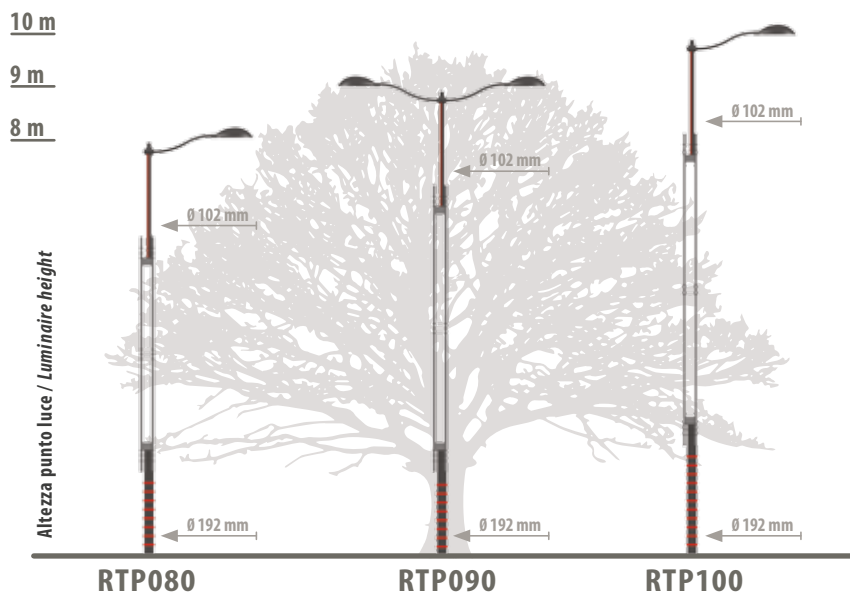

### Versioni Disponibili // Available Versions

RTP080 - RTP090 - RTP100 mensola singola o doppia / RTP080 - RTP090 - RTP100 single or double arm

Strisce luminose a LED e anelli decorativi abbinati fra loro disponibili in rosso, verde, blu o bianco / LED strips and decorative rings available in red, green, blue or white

Tipo di fissaggio: flangia o fondazione / Fixing type: flange or foundation

### Sbraccio // Extension

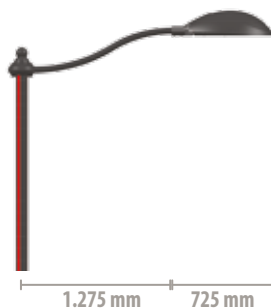



**illuminazione stradale // street lighting**









**Illuminazione stradale //**  
*street lighting*

**CORPI ILLUMINANTI //** *lighting fixtures*

- |     |                |
|-----|----------------|
| 98  | <b>ORN 400</b> |
| 100 | <b>ORN 500</b> |
| 102 | <b>ORN 600</b> |

# Orn

Minimale e tecnico, Orn è un apparecchio di illuminazione funzionale per il massimo risparmio energetico ed economico in termini di investimento a lungo periodo.

*Orn is essential and simple: a lighting fixture designed to ensure optimal energy and economic saving in terms of long-run investment.*



**ORN 400**

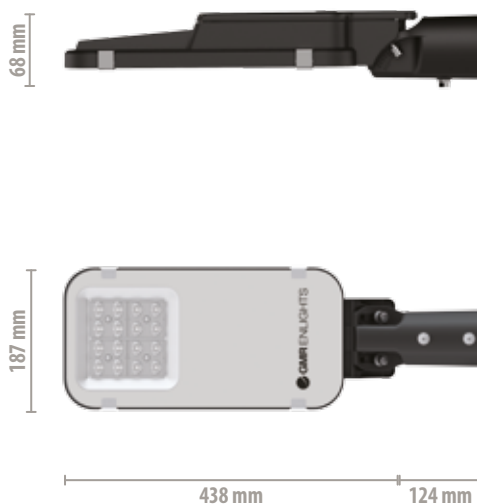

**OR4  
GLASSED**

**Specifiche Tecniche // Technical Features**

<b>MATERIALE:</b>	<b>MATERIAL:</b>	<b>OPENABLE</b>
pressofusione di alluminio, vetro.	die-cast aluminium, glass.	Apparecchio apribile e rigenerabile (componentistica interna sostituibile) con l'utilizzo di utensili. <i>Openable fixture with basic tools - Replaceable internal components using basic tools.</i>
<b>TEMPERATURA DI COLORE // COLOUR TEMPERATURE</b>		<b>TIPO DI FISSAGGIO // FIXING TYPE</b>
3000K // 4000K // 5700K		
<b>DIMMERABILE // DIMMABLE</b>		<b>TESTA-PALO // POLE-TOP</b>
<b>SISTEMI OTTICI // OPTICAL SYSTEMS</b>		<b>LATERALE // SIDE</b>
		<p>Regolabile con step da 5° <i>Adjustable with 5° steps</i></p> <p>+20°</p> <p>Regolabile con step da 5° <i>Adjustable with 5° steps</i></p> <p>+10° -20°</p>



**ORN 500**

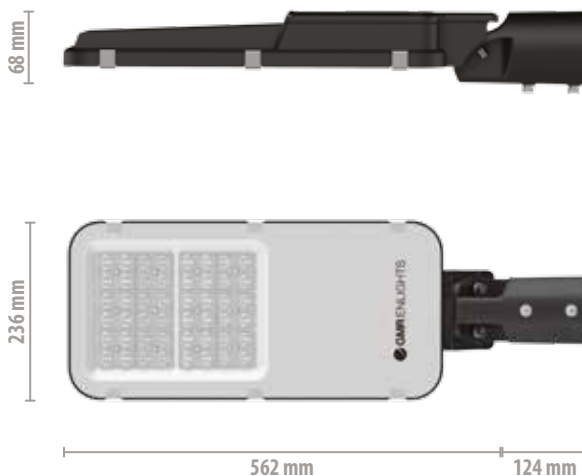

**OR5  
GLASSED**

**Specifiche Tecniche // Technical Features**

<b>MATERIALE:</b>	<b>MATERIAL:</b>	<b>OPENABLE</b>
pressofusione di alluminio, vetro.	die-cast aluminium, glass.	<p>Apparecchio apribile e rigenerabile (componentistica interna sostituibile) con l'utilizzo di utensili.  <i>Openable fixture with basic tools - Replaceable internal components using basic tools.</i></p>
<b>TEMPERATURA DI COLORE // COLOUR TEMPERATURE</b>		<b>TIPO DI FISSAGGIO // FIXING TYPE</b>
3000K // 4000K // 5700K		
<b>DIMMERABILE // DIMMABLE</b>		<b>TESTA-PALO // POLE-TOP</b>
<b>SISTEMI OTTICI // OPTICAL SYSTEMS</b>		<b>LATERALE // SIDE</b>
		<p>Regolabile con step da 5°  <i>Adjustable with 5° steps</i></p> <p>+20°</p> <p>Regolabile con step da 5°  <i>Adjustable with 5° steps</i></p> <p>+10° -20°</p>





**ORN 600**



**OR6  
GLASSED**

**Specifiche Tecniche // Technical Features**

<b>MATERIALE:</b>	<b>MATERIAL:</b>	<b>OPENABLE</b>	
pressofusione di alluminio, vetro.	die-cast aluminium, glass.	<p>Apparecchio apribile e rigenerabile (componentistica interna sostituibile) con l'utilizzo di utensili.  <i>Openable fixture with basic tools - Replaceable internal components using basic tools.</i></p>	
<b>TEMPERATURA DI COLORE // COLOUR TEMPERATURE</b>		<b>TIPO DI FISSAGGIO // FIXING TYPE</b>	
3000K // 4000K // 5700K			
<b>DIMMERABILE // DIMMABLE</b>		<b>TESTA-PALO // POLE-TOP</b>	
<b>SISTEMI OTTICI // OPTICAL SYSTEMS</b>		<b>LATERALE // SIDE</b>	
<p>· TYPE 2 ·    · TYPE 3 ·    · TYPE 4 ·</p>		<p>Regolabile con step da 5° Adjustable with 5° steps</p> <p>+20°</p>	<p>Regolabile con step da 5° Adjustable with 5° steps</p> <p>+10° -20°</p>

**Illuminazione stradale // street lighting**







## **Proiettori // floodlights**

108	<b>TARUS 200</b>
110	<b>TARUS 400</b>
114	<b>WOLTRON 1</b>
116	<b>WOLTRON 2</b>
118	<b>WOLTRON 3</b>
122	<b>CUBE</b>
124	<b>CUBE X</b>
126	<b>CUBE</b> MODULE COMBINING
130	<b>HIBRA</b>
132	<b>HIBRA</b> MODULE COMBINING

---

# Proiettori *floodlights*

Prodotti professionali sviluppati per soddisfare le più complesse richieste di illuminazione: grandi aree, impianti sportivi, contesti industriali e gallerie.

*Professional products designed to accommodate more complex lighting requirements: large areas, sports structures, industrial areas and tunnels.*





GMR ENLIGHTS

**TARUS 200**

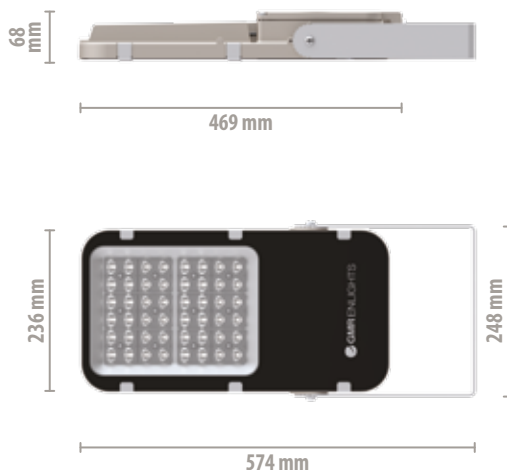

**TA2  
GLASSED**



Disponibile versione per gallerie // Tunnel version available **TT2**

**Specifiche Tecniche // Technical Features**

<p><b>MATERIALE:</b></p> <p><b>Corpo:</b> pressofusione di alluminio, vetro. <b>Staffa:</b> acciaio (TA2) / acciaio inox (TT2).</p>	<p><b>MATERIAL:</b></p> <p><b>Body:</b> die-cast aluminium, glass. <b>Bracket:</b> steel (TA2) / stainless steel (TT2).</p>	<p><b>OPENABLE</b></p> <p>Apparecchio apribile e rigenerabile (componentistica interna sostituibile) con l'utilizzo di utensili. <i>Openable fixture with basic tools - Replaceable internal components using basic tools.</i></p>	
<p><b>TEMPERATURA DI COLORE // COLOUR TEMPERATURE</b></p> <p>3000K // 4000K // 5700K</p>		<p><b>TIPO DI FISSAGGIO // FIXING TYPE</b></p>	
<p><b>DIMMERABILE // DIMMABLE</b></p>		<p>Regolabile con step da 5° // Adjustable with 5° steps</p>	<p>staffe per canale da 100 a 300 mm // brackets for 100 to 300 mm cable channel</p>
<p><b>SISTEMI OTTICI // OPTICAL SYSTEMS</b></p>		<p><b>CIMA-PALO // POLE-TOP</b></p>	<p><b>CANALE E PASSERELLE // CABLE CHANNEL SUPPORT</b></p>
		<p>Disponibile solo per versione TT2 // Available only for TT2 version</p>	



 GMR ENLIGHTS

**TARUS 400**

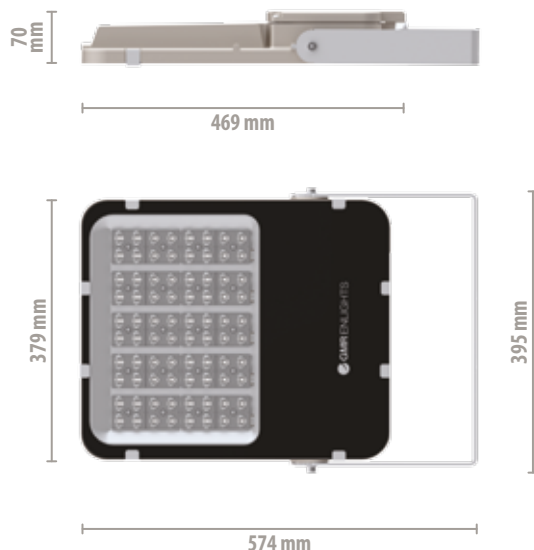

**TA4  
GLASSED**



Disponibile versione per gallerie // Tunnel version available **TT4**

**Specifiche Tecniche // Technical Features**

<b>MATERIALE:</b>	<b>MATERIAL:</b>
<b>Corpo:</b> pressofusione di alluminio, vetro. <b>Staffa:</b> acciaio (TA4) / acciaio inox (TT4).	<b>Body:</b> die-cast aluminium, glass. <b>Bracket:</b> steel (TA4) / stainless steel (TT4).
<b>TEMPERATURA DI COLORE // COLOUR TEMPERATURE</b>	
3000K // 4000K // 5700K	
<b>DIMMERABILE // DIMMABLE</b>	
<b>SISTEMI OTTICI // OPTICAL SYSTEMS</b>	

	<b>OPENABLE</b>
Apparecchio apribile e rigenerabile (componentistica interna sostituibile) con l'utilizzo di utensili. <i>Openable fixture with basic tools - Replaceable internal components using basic tools.</i>	

<b>TIPO DI FISSAGGIO // FIXING TYPE</b>		
Regolabile con step da 5° // Adjustable with 5° steps 	staffe per canale da 100 a 300 mm // brackets for 100 to 300 mm cable channel 	
<b>CIMA-PALO // POLE-TOP</b>	<b>STAFFA A PARETE - TORRE FARO // WALL BRACKET - LIGHTING TOWER</b>	<b>CANALE E PASSERELLE // CABLE CHANNEL SUPPORT</b>

Disponibile solo per versione TT4 // Available only for TT4 version

**Proiettori // floodlights**









## WOLTRON 1

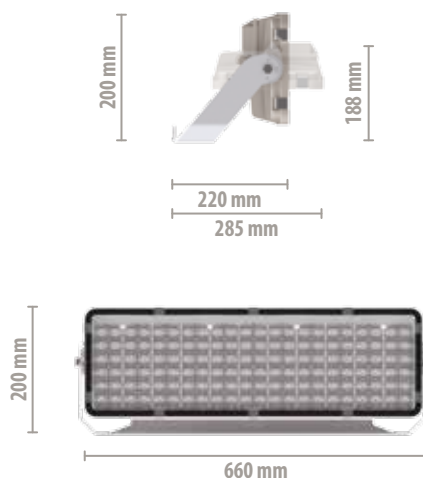

### W01 GLASSED



Disponibile versione per gallerie  
// Tunnel version available



**WT1**



Adatto per riprese televisive  
// Suitable for television broadcasts

**WS1**

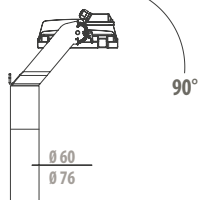
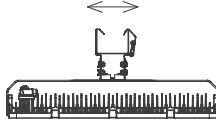
## Specifiche Tecniche // Technical Features

<p><b>MATERIALE:</b></p> <p>Corpo: pressofusione di alluminio, vetro. Staffa: acciaio (W01-W01-WS1) / acciaio inox (WT1).</p>	<p><b>MATERIAL:</b></p> <p>Body: die-cast aluminium, glass. Bracket: steel (W01-WS1) / stainless steel (WT1).</p>	<p><b>OPENABLE</b></p> <p>Apparecchio apribile e rigenerabile (componentistica interna sostituibile) con l'utilizzo di utensili. <i>Openable fixture with basic tools - Replaceable internal components using basic tools.</i></p>	
<p><b>TEMPERATURA DI COLORE // COLOUR TEMPERATURE</b></p> <p>3000K // 4000K // 5700K</p>		<p><b>TIPO DI FISSAGGIO // FIXING TYPE</b></p>	
<p><b>DIMMERABILE // DIMMABLE</b></p>		<p>Regolabile con step da 5° // Adjustable with 5° steps</p>  <p>90°</p> <p>90°</p> <p>90°</p>	<p>staffe per canale da 100 a 300 mm // brackets for 100 to 300 mm cable channel</p> 
<p><b>SISTEMI OTTICI // OPTICAL SYSTEMS</b></p>		<p><b>CIMA-PALO // POLE-TOP</b></p>	<p><b>CANALE E PASSERELLE // CABLE CHANNEL SUPPORT</b></p>
 <p>• TYPE 1 •    • TYPE 3 •    • 9 •    • 10 •    • 11 •</p>		<p>Disponibile solo per versione WT1 // Available only for WT1 version</p>	

Gruppo di alimentazione esterno **IP66** (disponibile in varie configurazioni) // External **IP66** power supply (available in several configurations)

Per maggiori informazioni vedi scheda tecnica prodotto // For more information see our product datasheet



**WOLTRON 2**

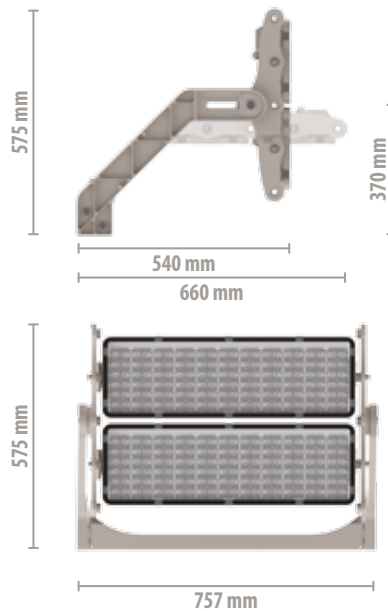

**W02  
GLASSED**



Adatto per riprese televisive // Suitable for television broadcasts **WS2**

**Specifiche Tecniche // Technical Features**

<b>MATERIALE:</b>	<b>MATERIAL:</b>
<b>Corpo:</b> pressofusione di alluminio, vetro. <b>Staffa:</b> acciaio, pressofusione di alluminio.	<b>Body:</b> die-cast aluminium, glass. <b>Bracket:</b> steel, die-cast aluminium.
<b>TEMPERATURA DI COLORE // COLOUR TEMPERATURE</b>	
3000K // 4000K // 5700K	
<b>DIMMERABILE // DIMMABLE</b>	
<b>SISTEMI OTTICI // OPTICAL SYSTEMS</b>	
Gruppo di alimentazione esterno <b>IP66</b> (disponibile in varie configurazioni) - cassetta di derivazione inclusa // External <b>IP66</b> power supply (available in several configurations) - junction box included	

**OPENABLE**

Apparecchio apribile e rigenerabile (componentistica interna sostituibile) con l'utilizzo di utensili.  
*Openable fixture with basic tools - Replaceable internal components using basic tools.*

**TIPO DI FISSAGGIO // FIXING TYPE**

<b>A PORTATA // VERTICAL</b>	<b>LATERALE // SIDE</b>	<b>SOSPENSIONE // SUSPENDED</b>

**REGOLAZIONI // ADJUSTMENTS**

<p>Regolazione longitudinale 100 mm // Longitudinal adjustment 100 mm</p>	<p>+ 40° Step 5° - 40°</p>
<b>PROIETTORE COMPLETO // COMPLETE FLOODLIGHT</b>	<b>SINGOLI MODULI // PER MODULE</b>



**WOLTRON 3**

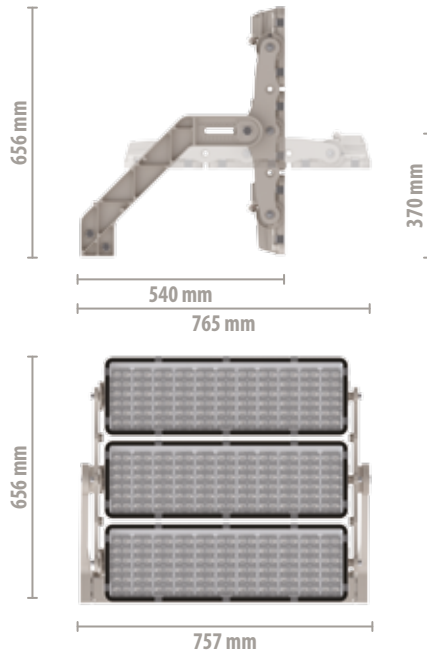

**W03  
GLASSED**



Adatto per riprese televisive // Suitable for television broadcasts **WS3**

**Specifiche Tecniche // Technical Features**

<b>MATERIALE:</b>	<b>MATERIAL:</b>
<b>Corpo:</b> pressofusione di alluminio, vetro. <b>Staffa:</b> acciaio, pressofusione di alluminio.	<b>Body:</b> die-cast aluminium, glass. <b>Bracket:</b> steel, die-cast aluminium.
<b>TEMPERATURA DI COLORE // COLOUR TEMPERATURE</b>	
3000K // 4000K // 5700K	
<b>DIMMERABILE // DIMMABLE</b>	
<b>SISTEMI OTTICI // OPTICAL SYSTEMS</b>	
Gruppo di alimentazione esterno <b>IP66</b> (disponibile in varie configurazioni) - cassetta di derivazione inclusa // External <b>IP66</b> power supply (available in several configurations) - junction box included	

	<b>OPENABLE</b>
Apparecchio apribile e rigenerabile (componentistica interna sostituibile) con l'utilizzo di utensili. <i>Openable fixture with basic tools - Replaceable internal components using basic tools.</i>	

<b>TIPO DI FISSAGGIO // FIXING TYPE</b>		
A PORTATA // VERTICAL	LATERALE // SIDE	SOSPENSIONE // SUSPENDED

<b>REGOLAZIONI // ADJUSTMENTS</b>	
Regolazione longitudinale 100 mm // Longitudinal adjustment 100 mm	+40° Step 5° -40°
<b>PROIETTORE COMPLETO // COMPLETE FLOODLIGHT</b>	<b>SINGOLI MODULI // PER MODULE</b>



**Proiettori // floodlights**





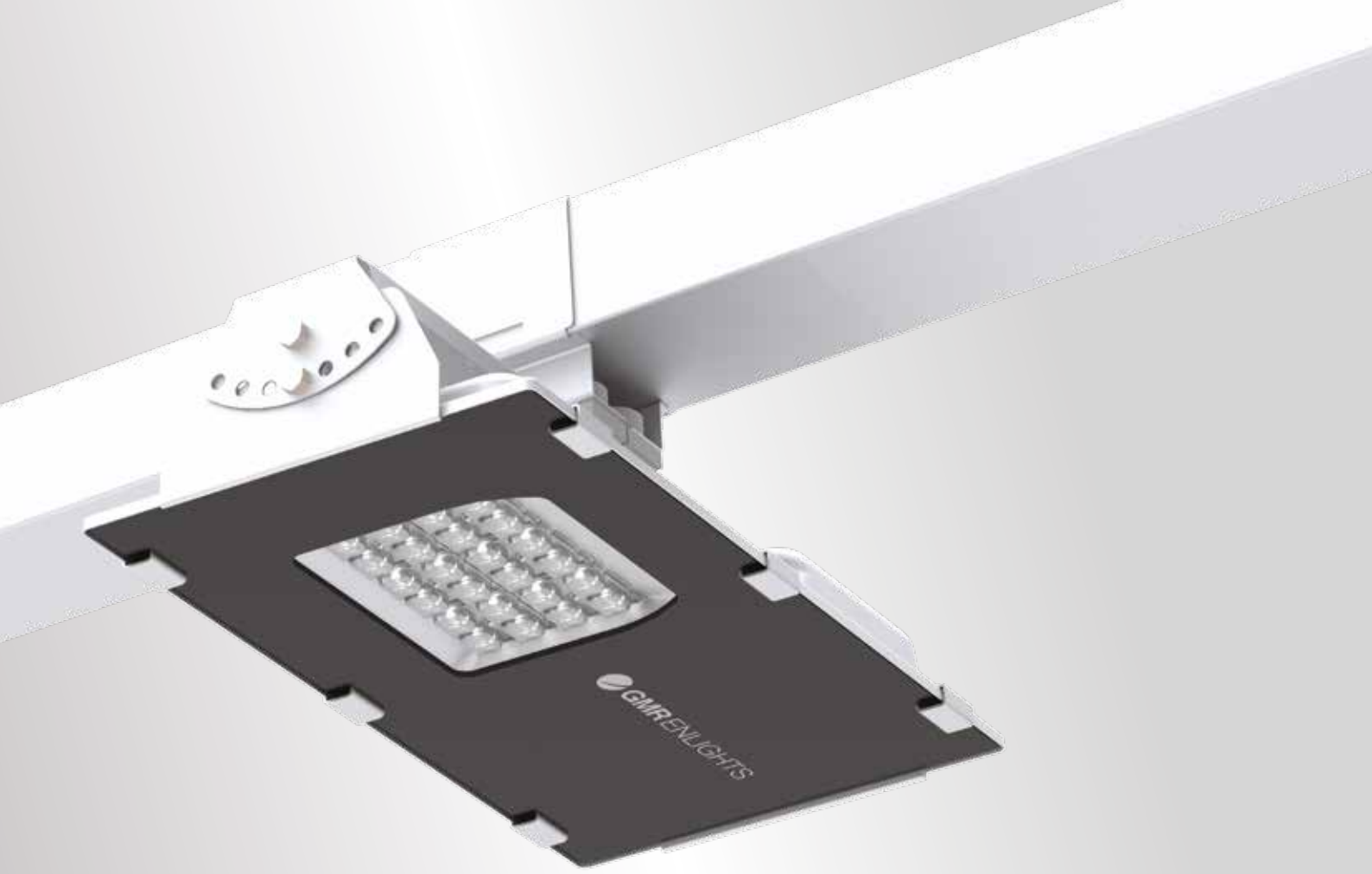

**CUBE**

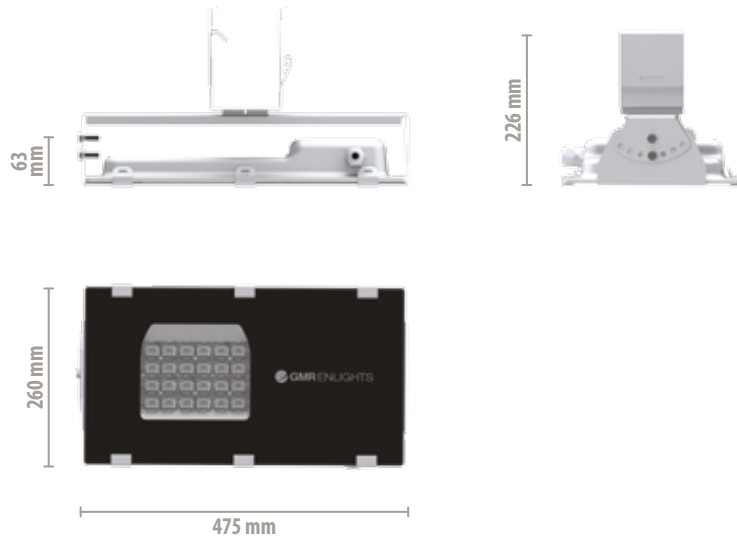

**CUB  
GLASSÉD**



Disponibile versione con fissaggio laterale per ambienti corrosivi  
// Side fixing type version for corrosive environment available

**CUB-S**

**Specifiche Tecniche // Technical Features**

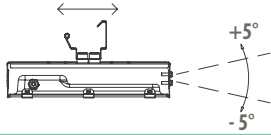
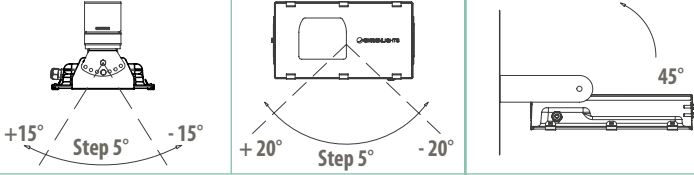
<p><b>MATERIALE:</b> Corpo: acciaio inox, vetro. Staffa: acciaio inox.</p>	<p><b>MATERIAL:</b> Body: stainless steel, glass. Bracket: stainless steel.</p>	<p><b>OPENABLE</b> Apparecchio apribile e rigenerabile (componentistica interna sostituibile) con l'utilizzo di utensili. <i>Openable fixture with basic tools - Replaceable internal components using basic tools.</i></p>
<p><b>TEMPERATURA DI COLORE // COLOUR TEMPERATURE</b> 4000K // 5700K</p>		<p><b>TIPO DI FISSAGGIO // FIXING TYPE</b></p>
<p><b>DIMMERABILE // DIMMABLE</b></p>		<p>staffe per canale da 100 a 300 mm // brackets for 100 to 300 mm cable channel</p> 
<p><b>SISTEMI OTTICI // OPTICAL SYSTEMS</b></p>		
<p>• TYPE 1 •    • TYPE 3 •    • 10 •    • 11 •</p>		<p><b>CANALE E PASSERELLE // CABLE CHANNEL SUPPORT</b>      <b>LATERALE // SIDE</b></p>

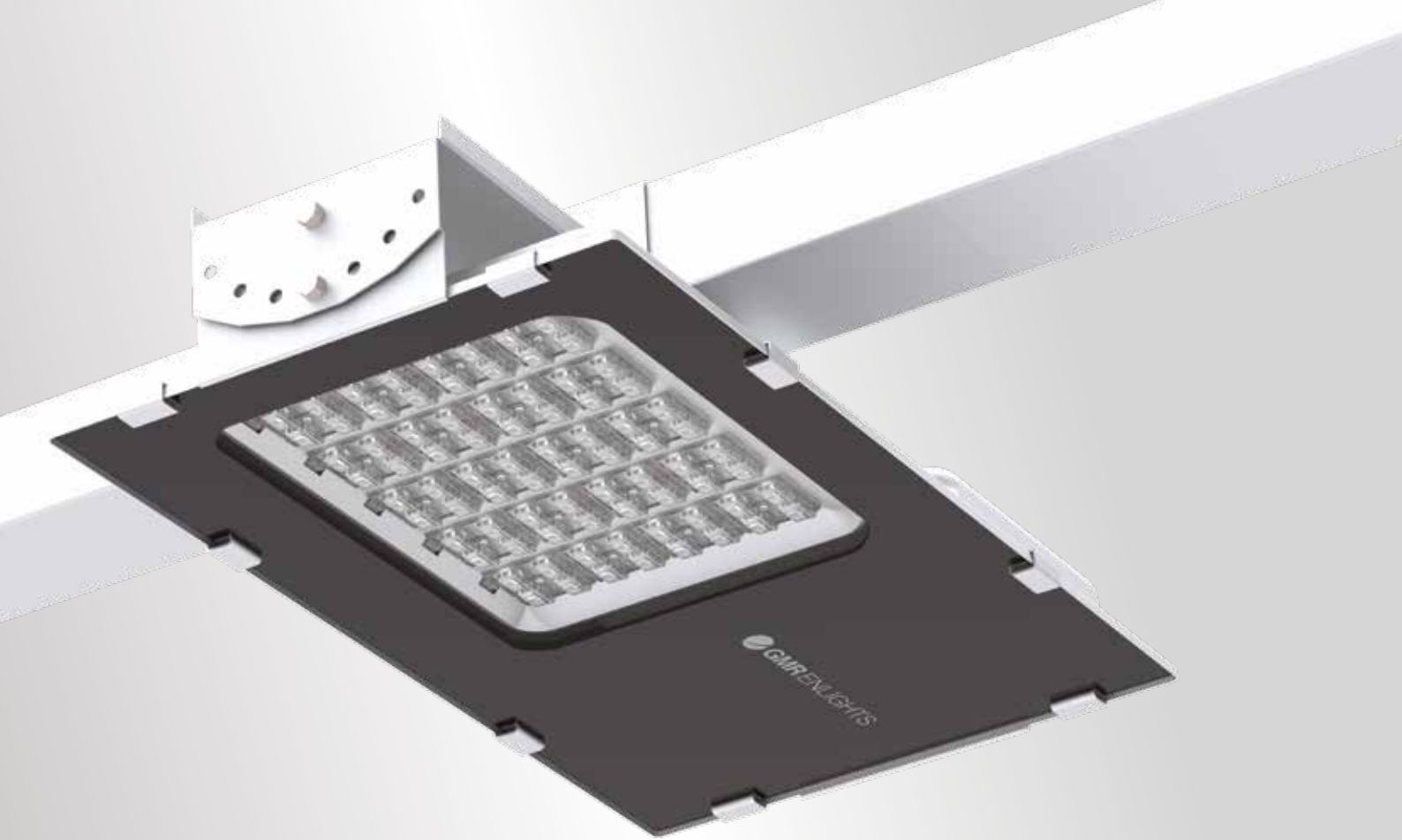

**CUBE X**

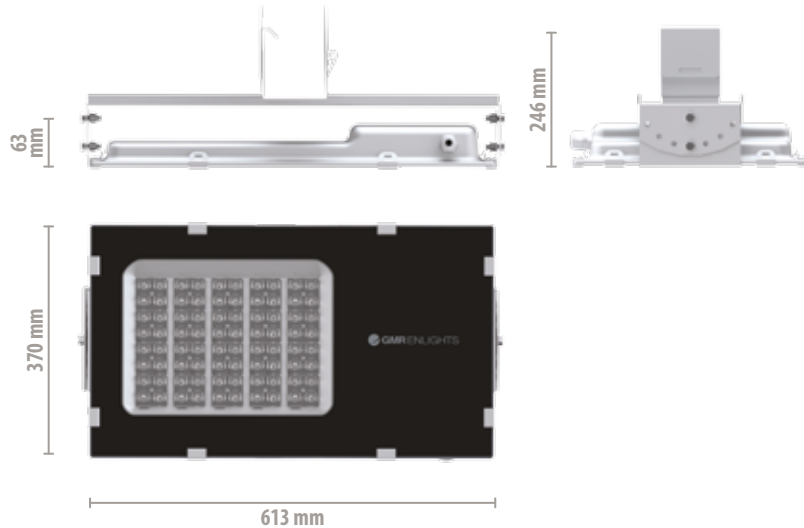

**CUX  
GLASSED**



Disponibile versione con fissaggio laterale per ambienti corrosivi  
// Side fixing type version for corrosive environment available

**CUX-S**

**Specifiche Tecniche // Technical Features**

<b>MATERIALE:</b> Corpo: trafilata di alluminio, acciaio inox, vetro. Staffa: acciaio inox.	<b>MATERIAL:</b> Body: extruded aluminium, stainless steel, glass. Bracket: stainless steel.
<b>TEMPERATURA DI COLORE // COLOUR TEMPERATURE</b> 4000K // 5700K	
<b>DIMMERABILE // DIMMABLE</b>	
<b>SISTEMI OTTICI // OPTICAL SYSTEMS</b>	

**OPENABLE**  
Apparecchio apribile e rigenerabile (componentistica interna sostituibile) con l'utilizzo di utensili.  
*Openable fixture with basic tools - Replaceable internal components using basic tools.*

**TIPO DI FISSAGGIO // FIXING TYPE**  
staffe per canale da 100 a 300 mm // brackets for 100 to 300 mm cable channel

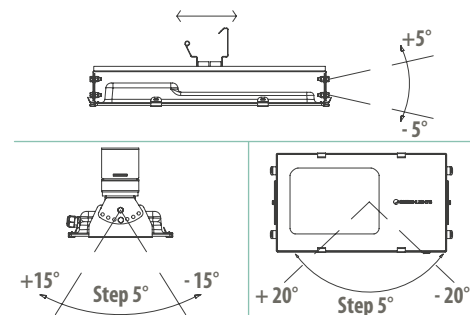

**CANALE E PASSERELLE // CABLE CHANNEL SUPPORT**

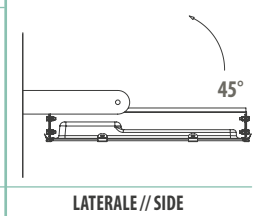

**LATERALE // SIDE**



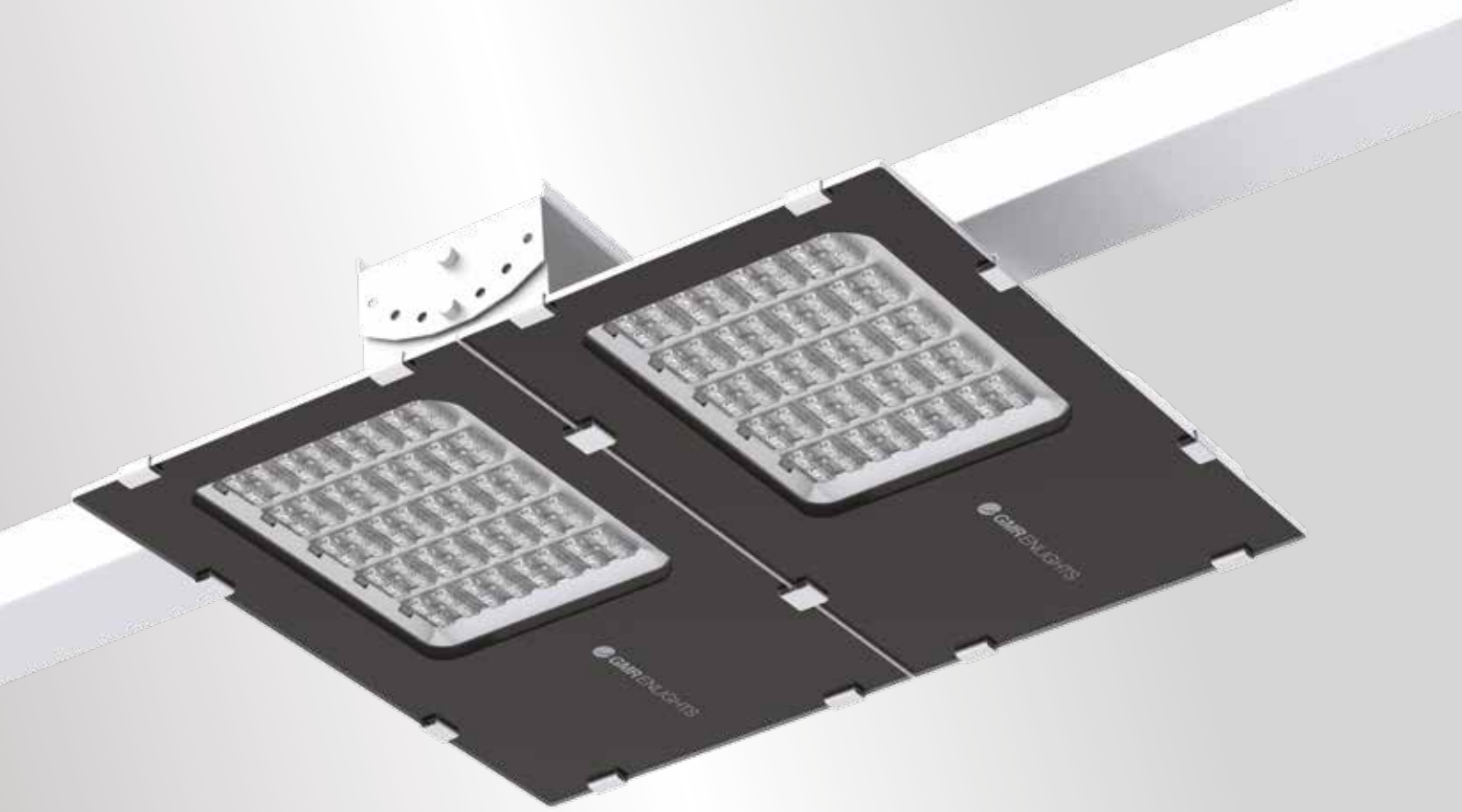

## CUBE MODULE COMBINING

Cube è appositamente studiato per l'illuminazione delle gallerie stradali e autostradali. È stato realizzato in due versioni dimensionali che possono essere utilizzate singolarmente o in differenti combinazioni, per soddisfare complesse esigenze di illuminazione, sia di tipo permanente che per il rinforzo degli imbocchi. Il corpo del prodotto, completamente in acciaio INOX stampato (non saldato), assicura lunga durata e corretto funzionamento anche in condizioni di stress fisico e in ambienti aggressivi. La meccanica dei sistemi di fissaggio è progettata per varie tipologie di regolazioni che permettono ampia versatilità sia in fase di progettazione che di installazione.

*Cube is designed for tunnels and highways lighting. It is available in 2 dimensional versions that can be used alone or in various combinations to meet complex lighting needs, for both permanent and reinforced lighting for tunnel entries. The floodlight body is entirely made of deep drawing stainless steel (without welding) and it ensures a long durability and a proper functioning even under physical stress and in aggressive environments too. The mechanics of fixing systems is designed for various types of adjustment that provides a wide versatility for both the design and installation phase.*

### Soluzioni Modulari // Modular Solutions

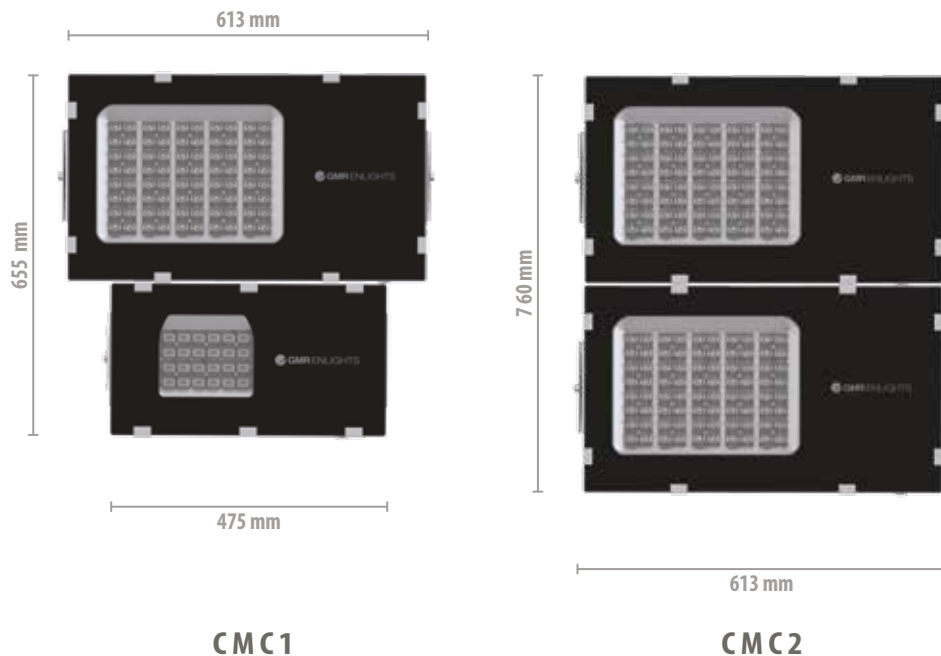

**Proiettori // floodlights**







**HIBRA**

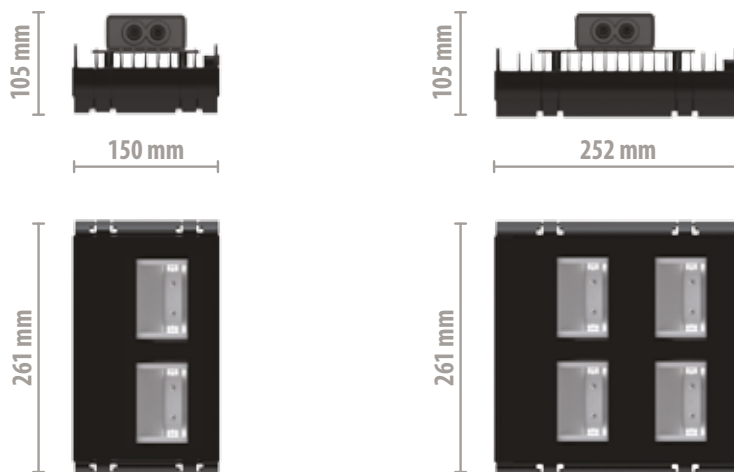

**HI1**

**HI2**

**REFLEXA**



Disponibile versione stradale a parete  
// Wall mounted street version available

**Specifiche Tecniche // Technical Features**

<b>MATERIALE:</b>	<b>MATERIAL:</b>
-------------------	------------------

pressofusione di alluminio, vetro.

die-cast aluminium, glass.

<b>TEMPERATURA DI COLORE // COLOUR TEMPERATURE</b>
--

3000K // 4000K // 5700K

<b>DIMMERABILE // DIMMABLE</b>
--------------------------------

<b>SISTEMI OTTICI // OPTICAL SYSTEMS</b>
--



• R2 • • R3 • • R9 • • R10 •

Gruppo di alimentazione esterno **IP66**  
(disponibile in varie configurazioni) //  
External **IP66** power supply (available in several configurations)

	<b>OPENABLE</b>
--	-----------------

Apparecchio apribile e rigenerabile  
(componentistica interna sostituibile) con l'utilizzo di utensili.  
*Openable fixture with basic tools - Replaceable internal components using basic tools.*

<b>TIPO DI FISSAGGIO // FIXING TYPE</b>
---

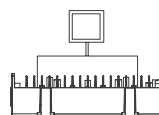

BLINDO // BUSBAR

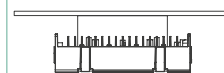

FISSAGGIO A SOFFITTO // CEILING

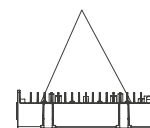

CAVI DI ACCIAIO // STEEL CABLES



OCCHIELLO // LOOP

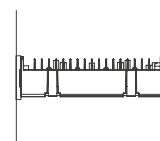

A PARETE // ON WALL

A SOSPENSIONE // SUSPENDED



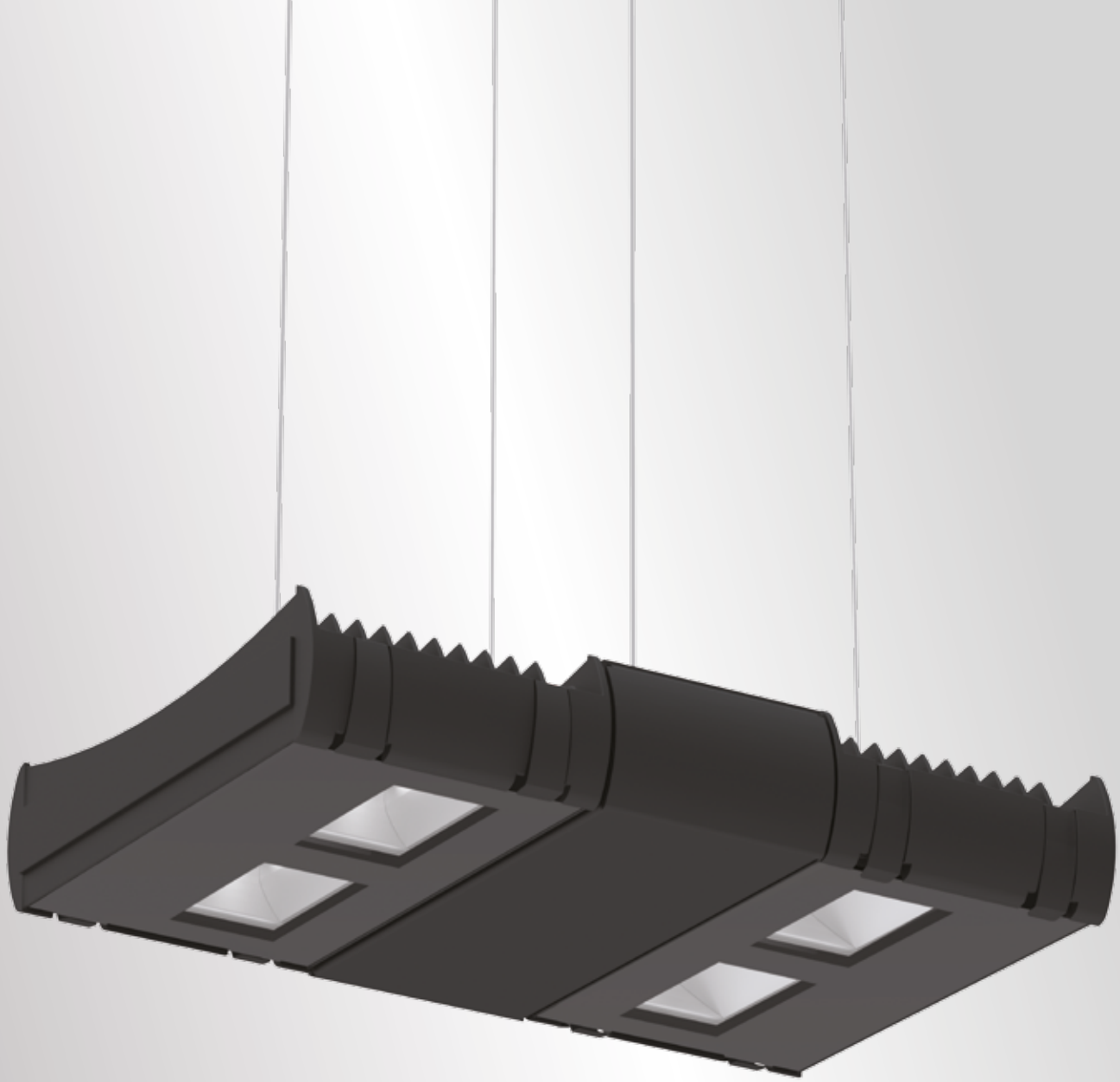

## HIBRA MODULE COMBINING

“Hibra” è un apparecchio high bay modulare e flessibile, utilizzabile in otto diverse geometrie e combinazioni. Grazie alla tecnologia ottica a riflessione sono disponibili numerose soluzioni illuminotecniche. L'apparecchio è predisposto per l'alloggiamento di sensori (Soluzioni Modulari Plus) e ha più possibilità di installazione.

*“Hibra” is a high bay modular and flexible device that can be used in eight different setups and combinations. Thanks to its optical reflection technology it offers many different lighting solutions. This device is pre-arranged for the sensors housing (Plus Modular Solutions). “Hibra” has more installation options.*

### Soluzioni Modulari Basic // Basic Modular Solutions

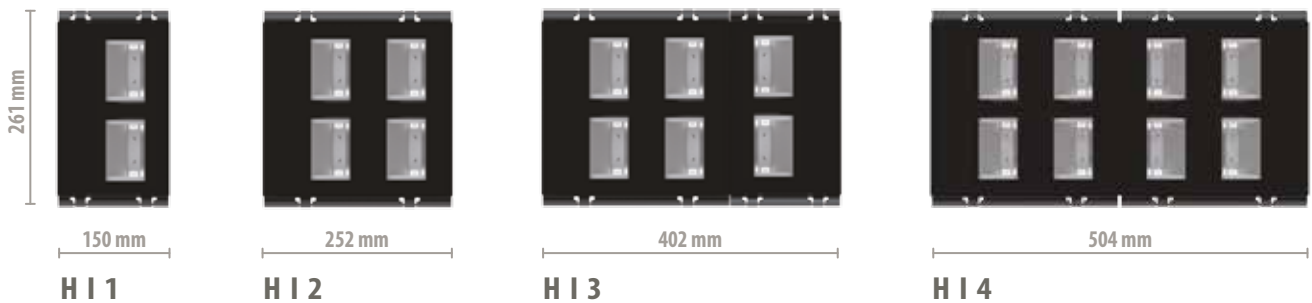

### Soluzioni Modulari Plus // Plus Modular Solutions

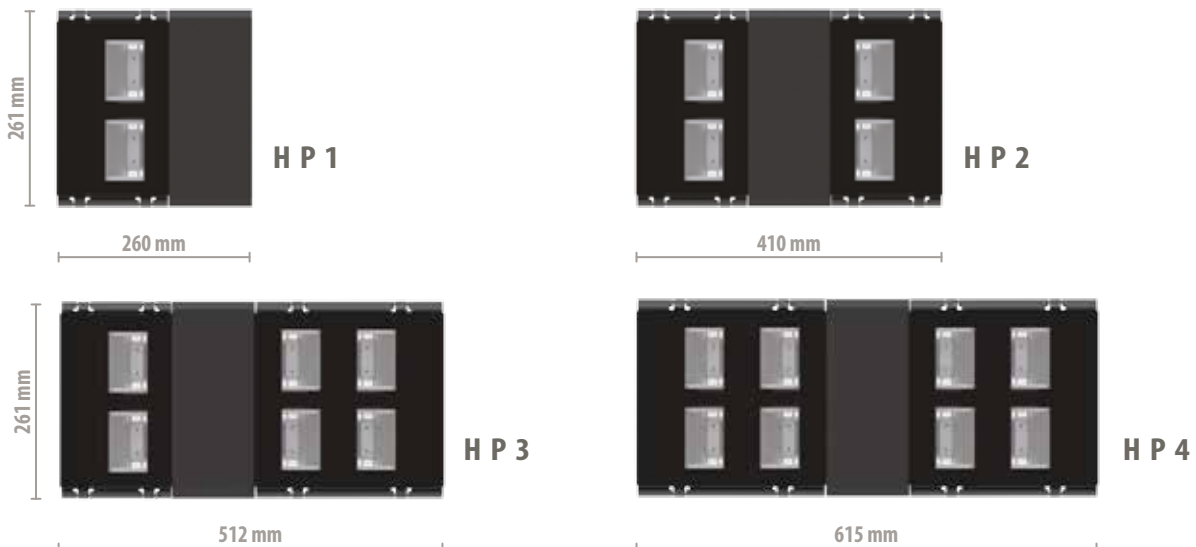

**Proiettori // floodlights**









**illuminazione di arredo  
urbano contemporaneo //**  
*contemporary urban lighting*

**CORPI ILLUMINANTI // *lighting fixtures***

- 138 **VESTA A SMALL**
- 140 **VESTA B SMALL**
- 142 **VESTA C**
- 144 **VESTA A LARGE**
- 146 **VESTA B LARGE**

**PALI // *poles***

- 150 **VESTA RAL POLE**
- 154 **VESTA KLEPSY POLE**
- 158 **VESTA DOMINO POLE**
- 162 **VESTA STEGO POLE**
- 166 **VESTA MEDUSA POLE**

**MENSOLE A MURO // *wall brackets***

- 170 **VESTA WALL BRACKET**

---

# V e s t a

Vesta: un disco dalla forma primordiale, che, con un'eleganza composta, si rifugia dietro a più forme.

*Vesta appears as a disc that evolves in multiple shapes with delicate elegance.*





**VESTA A SMALL**



**VAS  
GLASSED**

**Specifiche Tecniche // Technical Features**

<p><b>MATERIALE:</b></p>	<p><b>MATERIAL:</b></p>	<p><b>TIMELESS</b></p>
<p>pressofusione di alluminio, vetro.</p>	<p>die-cast aluminium, glass.</p>	<p>Apparecchio apribile e rigenerabile (componentistica interna sostituibile) senza utilizzo di utensili. <i>Tool-free openable fixture - Replaceable internal components without the need of tools.</i></p>
<p><b>TEMPERATURA DI COLORE // COLOUR TEMPERATURE</b></p>		<p><b>TIPO DI FISSAGGIO // FIXING TYPE</b></p>
<p>2200K // 3000K // 4000K // 5700K</p>		
<p><b>DIMMERABILE // DIMMABLE</b></p>		<p><b>SOSPENSIONE // SUSPENDED</b>      <b>TESATA DI FUNE // WIRE SYSTEM</b></p>
<p><b>SISTEMI OTTICI // OPTICAL SYSTEMS</b></p>		
<p>· TYPE 1 ·   · TYPE 2 ·   · TYPE 3 ·   · TYPE 4 ·   · TYPE 5 ·</p>		



**VESTA B SMALL**

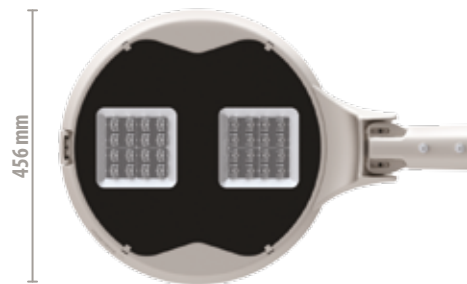

**VBS  
GLASSED**

**Specifiche Tecniche // Technical Features**

<p><b>MATERIALE:</b></p>	<p><b>MATERIAL:</b></p>	<p><b>TIMELESS</b></p>
<p>pressofusione di alluminio, vetro.</p>	<p>die-cast aluminium, glass.</p>	<p>Apparecchio apribile e rigenerabile (componentistica interna sostituibile) senza utilizzo di utensili. <i>Tool-free openable fixture - Replaceable internal components without the need of tools.</i></p>
<p><b>TEMPERATURA DI COLORE // COLOUR TEMPERATURE</b></p>		<p><b>TIPO DI FISSAGGIO // FIXING TYPE</b></p>
<p>2200K // 3000K // 4000K // 5700K</p>		
<p><b>DIMMERABILE // DIMMABLE</b></p>		<p><b>TESTA-PALO // POLE-TOP</b></p>
<p><b>SISTEMI OTTICI // OPTICAL SYSTEMS</b></p>		<p>Regolabile con step da 5° <i>Adjustable with 5° steps</i></p>
		<p><b>LATERALE // SIDE</b></p> <p>Regolabile con step da 5° <i>Adjustable with 5° steps</i></p> <p>+10° -20°</p>



**VESTA C**

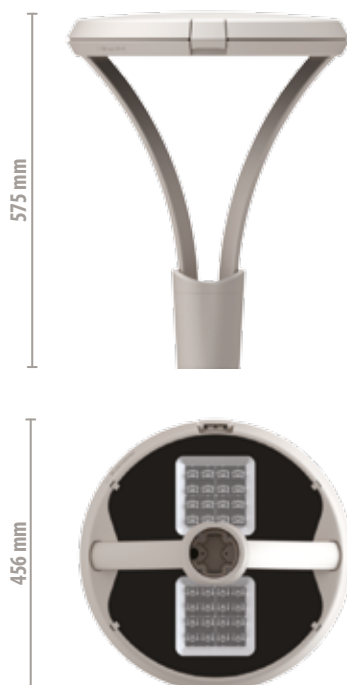

**VCS  
GLASSÉD**

**Specifiche Tecniche // Technical Features**

<p><b>MATERIALE:</b> trafila di alluminio, pressofusione di alluminio, vetro.</p>	<p><b>MATERIAL:</b> extruded aluminium, die-cast aluminium, glass.</p>	<p><b>TIMELESS</b> Apparecchio apribile e rigenerabile (componentistica interna sostituibile) senza utilizzo di utensili. <i>Tool-free openable fixture - Replaceable internal components without the need of tools.</i></p>
<p><b>TEMPERATURA DI COLORE // COLOUR TEMPERATURE</b> 2200K // 3000K // 4000K // 5700K</p>		<p><b>TIPO DI FISSAGGIO // FIXING TYPE</b></p>
<p><b>DIMMERABILE // DIMMABLE</b></p>		
<p><b>SISTEMI OTTICI // OPTICAL SYSTEMS</b></p> <p>• TYPE 2 •    • TYPE 3 •    • TYPE 4 •    • TYPE 5 •</p>		





**VESTA A LARGE**



**VAL  
GLASSED**

**Specifiche Tecniche // Technical Features**

<p><b>MATERIALE:</b></p>	<p><b>MATERIAL:</b></p>	<p><b>TIMELESS</b></p>
<p>pressofusione di alluminio, vetro.</p>	<p>die-cast aluminium, glass.</p>	<p>Apparecchio apribile e rigenerabile (componentistica interna sostituibile) senza utilizzo di utensili. <i>Tool-free openable fixture - Replaceable internal components without the need of tools.</i></p>
<p><b>TEMPERATURA DI COLORE // COLOUR TEMPERATURE</b></p>		<p><b>TIPO DI FISSAGGIO // FIXING TYPE</b></p>
<p>2200K // 3000K // 4000K // 5700K</p>		
<p><b>DIMMERABILE // DIMMABLE</b></p>		
<p><b>SISTEMI OTTICI // OPTICAL SYSTEMS</b></p>		<p><b>SOSPENSIONE // SUSPENDED</b></p>
		<p><b>TESATA DI FUNE // WIRE SYSTEM</b></p>





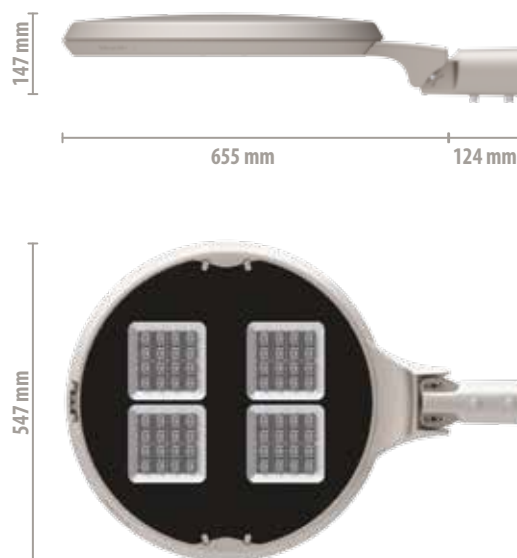

## VESTA B LARGE

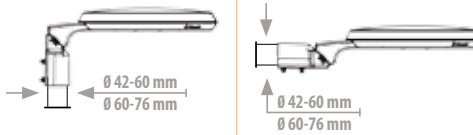

### VBL GLASSED

## Specifiche Tecniche // Technical Features

<b>MATERIALE:</b>	<b>MATERIAL:</b>	 <b>TIMELESS</b>
pressofusione di alluminio, vetro.	die-cast aluminium, glass.	Apparecchio apribile e rigenerabile (componentistica interna sostituibile) senza utilizzo di utensili. <i>Tool-free openable fixture - Replaceable internal components without the need of tools.</i>
<b>TEMPERATURA DI COLORE // COLOUR TEMPERATURE</b>		<b>TIPO DI FISSAGGIO // FIXING TYPE</b>
2200K // 3000K // 4000K // 5700K		
<b>DIMMERABILE // DIMMABLE</b>		<b>TESTA-PALO // POLE-TOP</b>
<b>SISTEMI OTTICI // OPTICAL SYSTEMS</b>		<b>LATERALE // SIDE</b>
 <p>• TYPE 2 •   • TYPE 3 •   • TYPE 4 •   • TYPE 5 •</p>		Regolabile con step da 5° <i>Adjustable with 5° steps</i>  +20°
		Regolabile con step da 5° <i>Adjustable with 5° steps</i>  +10° -20°

**illuminazione di arredo urbano contemporaneo //**  
*contemporary urban lighting*









## VESTA RAL POLE

“Vesta Ral”, dalla forma cilindrica, realizzato in acciaio e trafilato di alluminio, è impreziosito da tre sottili decori luminosi a LED che lo percorrono lungo la sua altezza.

*“Vesta Ral” is characterized by a cylindrical shape, it is made of steel and extruded aluminium. It is enriched by three thin LED decorations across its entire height.*

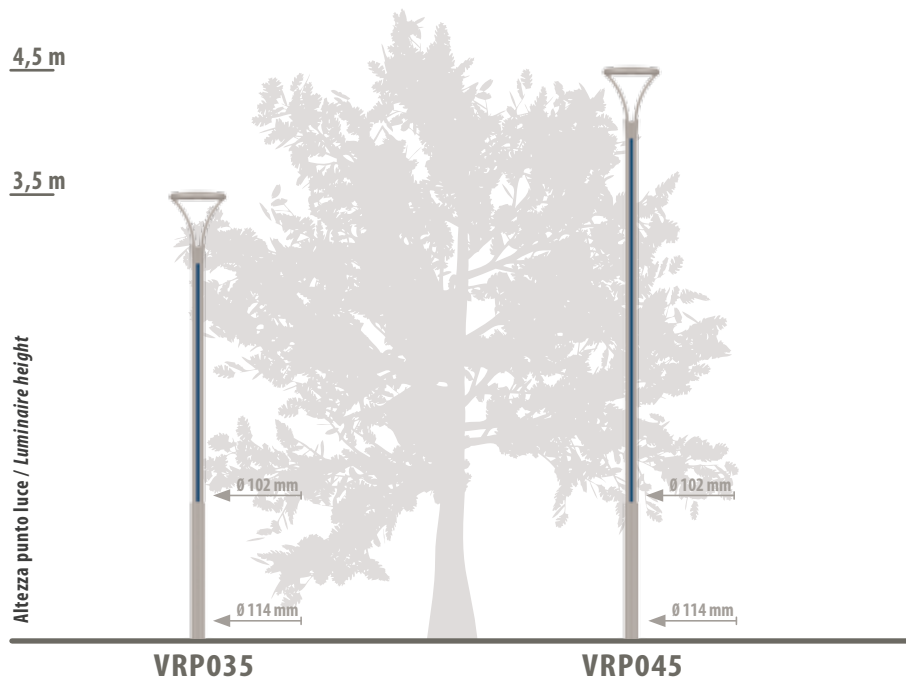

### Versioni Disponibili // Available Versions

Disponibile solo per corpo illuminante Vesta C / Only available for luminaire Vesta C

Strisce luminose a LED disponibili in rosso, verde, blu o bianco / LED strips available in red, green, blue or white

Tipo di fissaggio: flangia o fondazione / Fixing type: flange or foundation

**illuminazione di arredo urbano contemporaneo //**  
*contemporary urban lighting*









## VESTA KLEPSY POLE

“Vesta Klepsy”, dalla particolare forma ondulata, sfrutta appieno la tecnologia di laminatura del tubo d'acciaio.

*“Vesta Klepsy, with a special wavy shape, takes the best out of the steel hot rolling technology.*

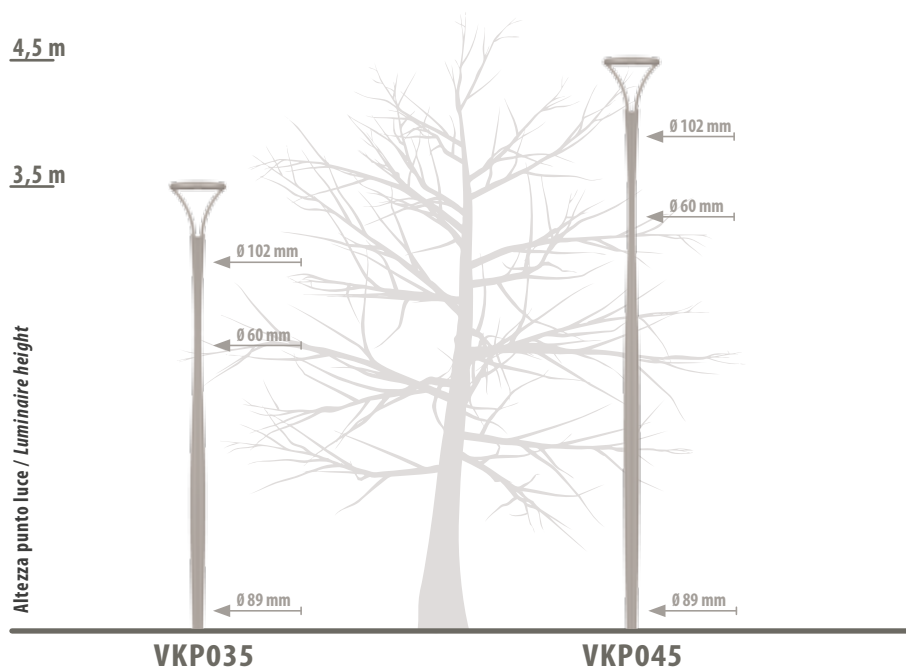

### Versioni Disponibili // Available Versions

Disponibile solo per corpo illuminante Vesta C / Only available for luminaire Vesta C

Tipo di fissaggio: flangia o fondazione / Fixing type: flange or foundation



**illuminazione di arredo urbano contemporaneo //**  
*contemporary urban lighting*









## VESTA DOMINO POLE

“Vesta Domino”, realizzato in acciaio conico senza saldature a vista, si distingue per l’inclinazione longitudinale che crea un effetto di movimento domino.

“Vesta Domino”, made of conical steel without any visible welding, is distinguished by its longitudinal inclination that creates a domino effect.

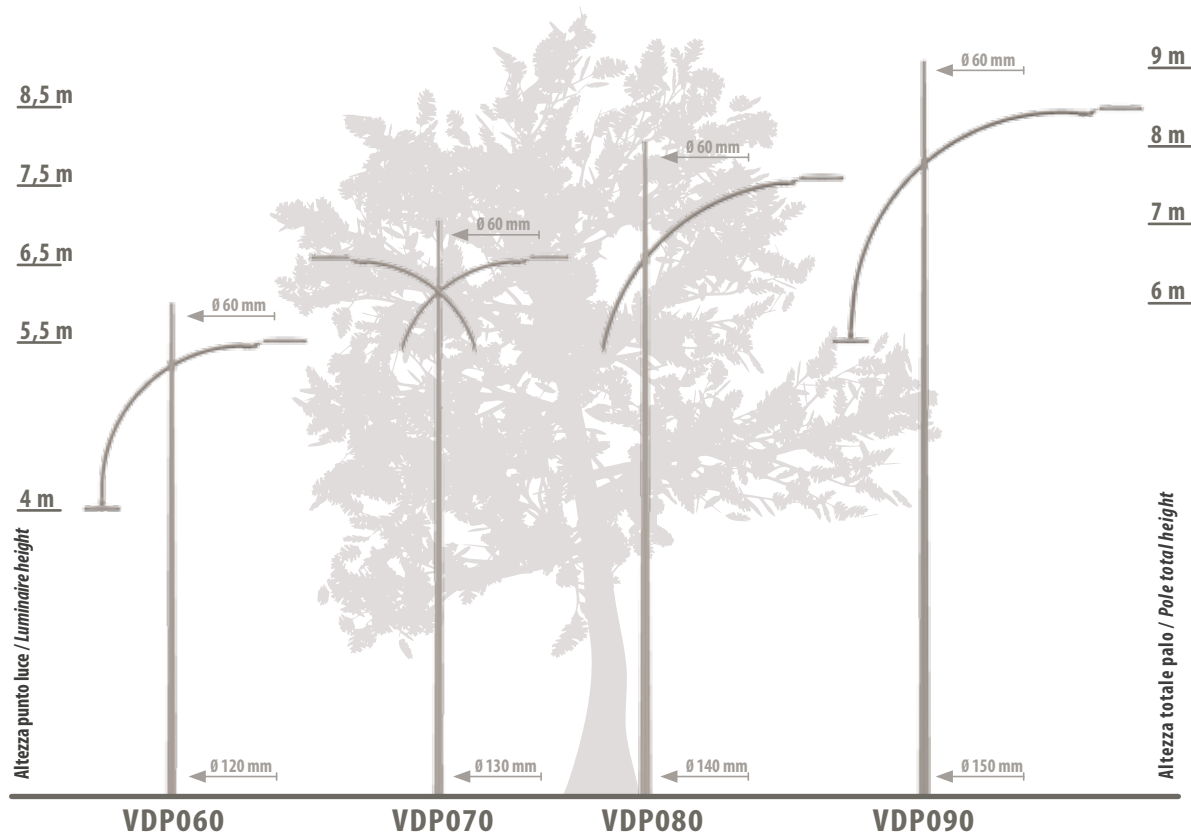

### Versioni Disponibili // Available Versions

Mensola singola, doppia o sfalsata / Single, double or split-level arm

Singolo e doppio disponibile con Vesta B, sfalsato con Vesta B e Vesta A / Single and double, available with Vesta B, split-level available with Vesta B and Vesta A

Pali inclinati di 7° sul lato longitudinale / Poles are inclined by 7° on the longitudinal side

Tipo di fissaggio: flangia o fondazione / Fixing type: flange or foundation

### Sbraccio // Extension

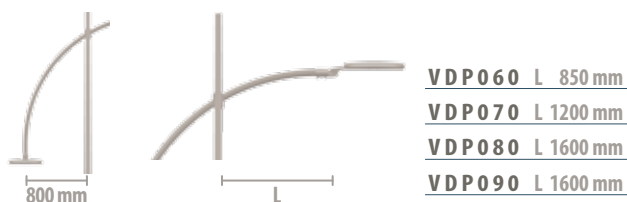



**illuminazione di arredo urbano contemporaneo //**  
*contemporary urban lighting*









## VESTA STEGO POLE

“Vesta Stego” è caratterizzato da un doppio sostegno conico in acciaio senza saldature a vista: due pali intrecciati, che rendono unica l’illuminazione di strade e percorsi ciclo-pedonali.

“Vesta Stego” is characterized by a double conical support made of steel without visible welding. Two overlapping poles that create a unique type of lighting for roads and cycle pedestrian paths.

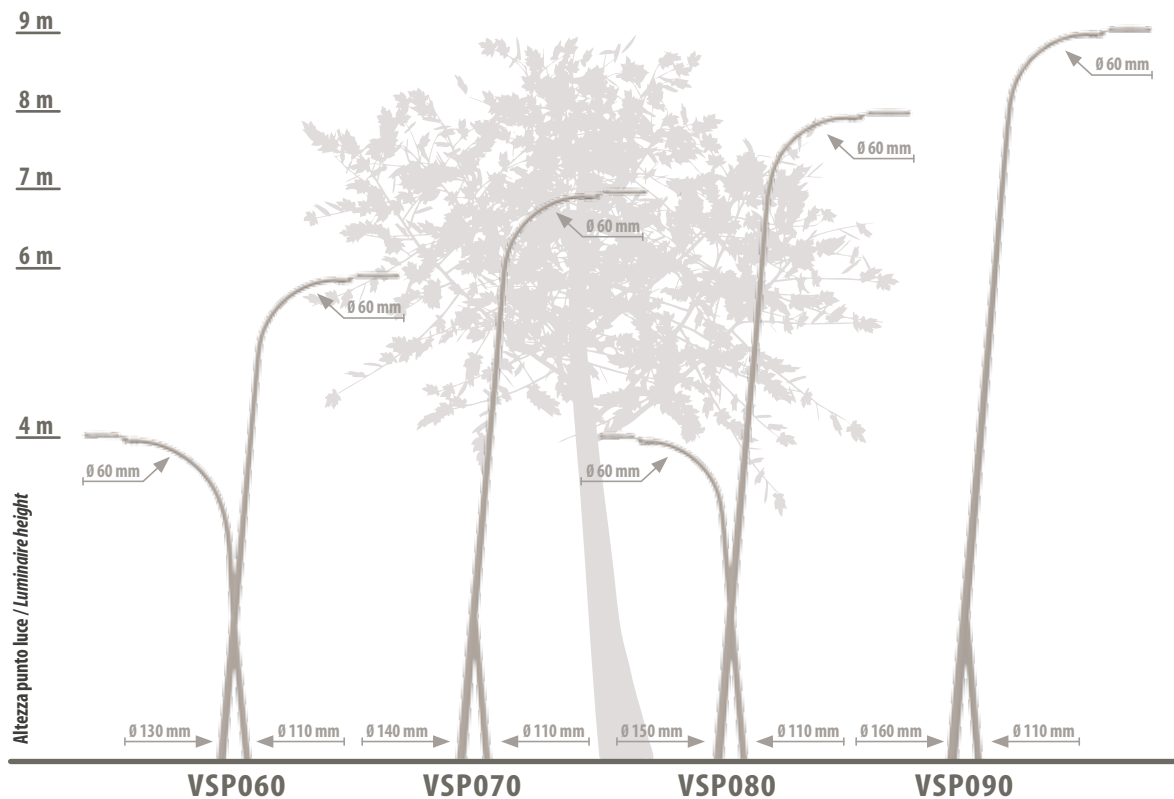

### Versioni Disponibili // Available Versions

Disponibile solo per corpo illuminante Vesta B / Available only for Vesta B lighting fixture

Mensola singola, doppia o sfalsata / Single, double or split-level arm

Tipo di fissaggio: flangia o fondazione / Fixing type: flange or foundation

### Sbraccio // Extension

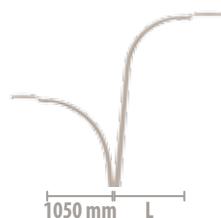

**VSP060 L 1350 mm**

**VSP070 L 1450 mm**

**VSP080 L 1550 mm**

**VSP090 L 1650 mm**

**illuminazione di arredo urbano contemporaneo //**  
*contemporary urban lighting*









**VESTA MEDUSA POLE**

“Vesta Medusa” dal design elicoidale è realizzato in acciaio conico laminato senza saldature. I corpi illuminanti Vesta con attacco laterale, perfettamente inseriti nel gioco di movimenti della struttura, permettono un’illuminazione a 360°. Il puntale luminoso a LED completa il fascino della collezione.

“Vesta Medusa” with its helicoidal design is made of rolled conical steel without welding. Vesta-B lighting fixtures are perfectly integrated in the dynamic structure of the Vesta “Medusa” pole, providing a full 360° lighting. The LED decorative tip gives the final touch to the collection.

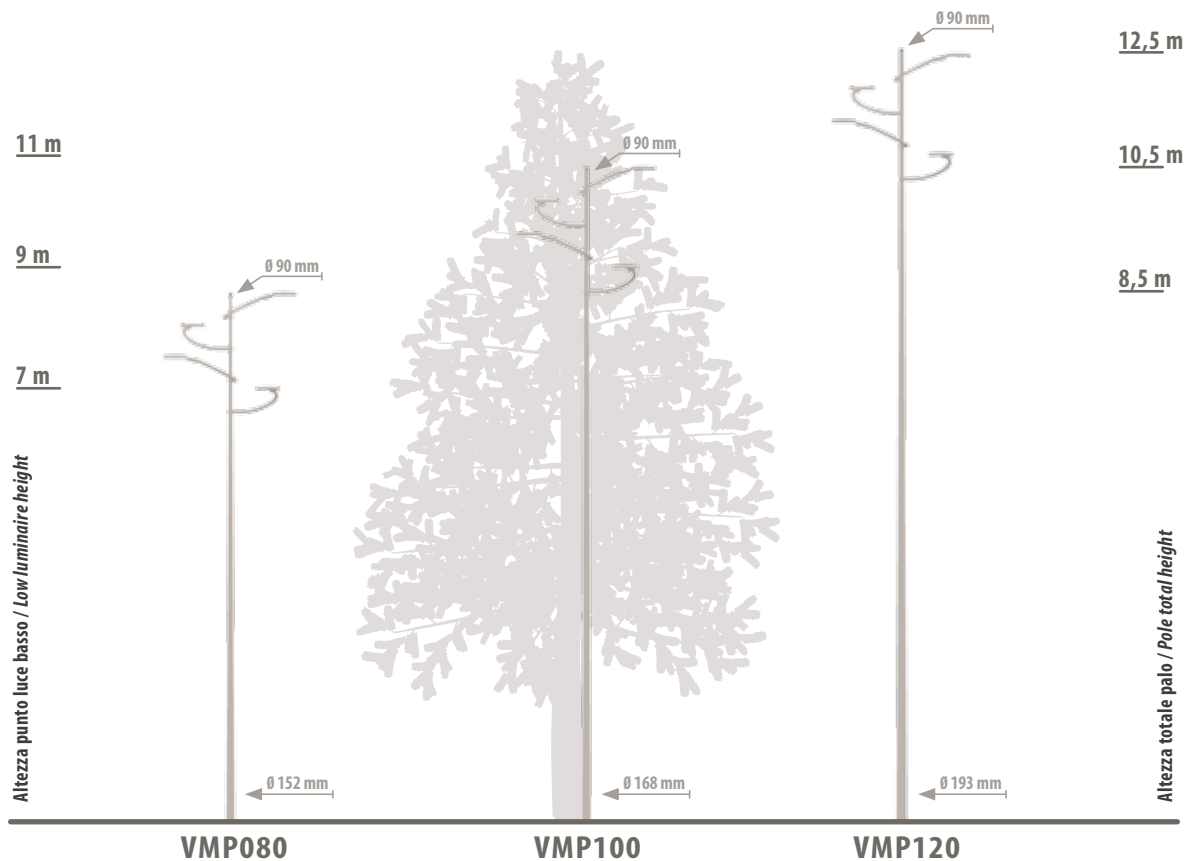

**VMP080**

**VMP100**

**VMP120**

**Versioni Disponibili // Available Versions**

Disponibile solo per corpo illuminante Vesta B / Available only for Vesta B lighting fixture  
 Tipo di fissaggio: flangia o fondazione / Fixing type: flange or foundation

**Sbraccio // Extension**

**In dotazione // Supplied**



Puntale LED / LED decorative tip



**illuminazione di arredo urbano contemporaneo //**  
*contemporary urban lighting*







## VESTA WALL BRACKET

Le mensole a muro "Vesta", in acciaio conico curvo, completano la collezione.

*"Vesta" wall brackets, made of curved conical steel, complete the Vesta collection.*

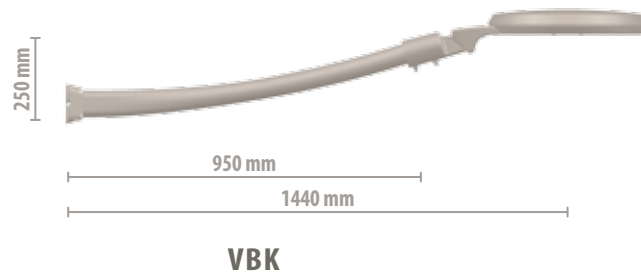
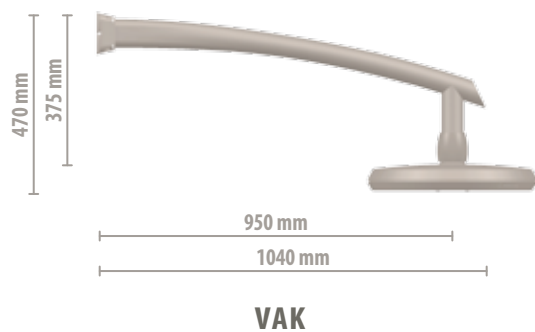
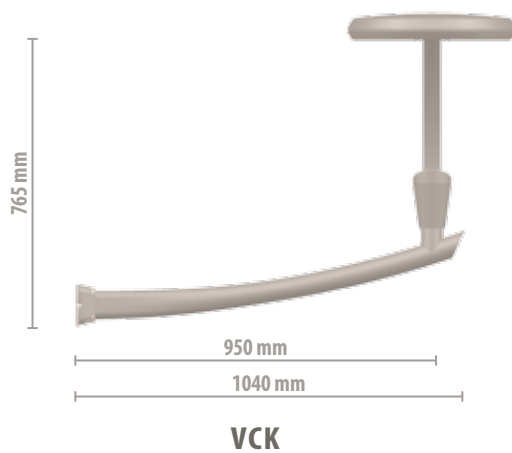

### Versioni Disponibili // Available Versions

VAK disponibile per Vesta A / VAK available for Vesta A

VBK disponibile per Vesta B / VBK available for Vesta B

VCK disponibile per Vesta C / VCK available for Vesta C



**illuminazione di arredo urbano contemporaneo //**  
*contemporary urban lighting*









**Illuminazione di arredo  
urbano contemporaneo //**  
*contemporary urban lighting*

**CORPI ILLUMINANTI // *lighting fixtures***

176	<b>VIRGO A 400</b>
178	<b>VIRGO B 400</b>
180	<b>VIRGO C 400</b>
184	<b>VIRGO A 500</b>
186	<b>VIRGO B 500</b>
188	<b>VIRGO C 500</b>

---

# Virgo

Virgo è un apparecchio minimale e versatile per l'illuminazione funzionale dello spazio urbano contemporaneo.

*Virgo is a minimalist and versatile fixture for contemporary urban spaces's functional lighting.*



**VIRGO A 400**

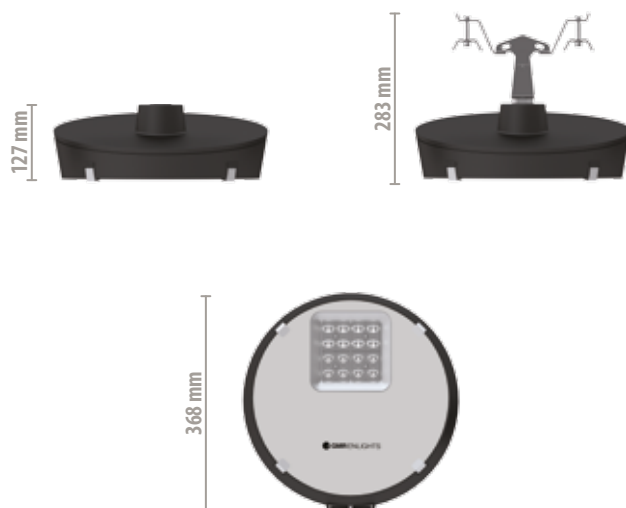

**VA 4  
GLASSED**

**Specifiche Tecniche // Technical Features**

<p><b>MATERIALE:</b> pressofusione di alluminio, vetro.</p>	<p><b>MATERIAL:</b> die-cast aluminium, glass.</p>	<p><b>OPENABLE</b> Apparecchio apribile e rigenerabile (componentistica interna sostituibile) con l'utilizzo di utensili. <i>Openable fixture with basic tools - Replaceable internal components using basic tools.</i></p>
<p><b>TEMPERATURA DI COLORE // COLOUR TEMPERATURE</b> 2200K // 3000K // 4000K // 5700K</p>		<p><b>TIPO DI FISSAGGIO // FIXING TYPE</b></p>
<p><b>DIMMERABILE // DIMMABLE</b></p>		
<p><b>SISTEMI OTTICI // OPTICAL SYSTEMS</b></p>		<p><b>SOSPENSIONE // SUSPENDED</b>      <b>TESATA DI FUNE // WIRE SYSTEM</b></p>



**VIRGO B 400**



**VB4  
GLASSED**

**Specifiche Tecniche // Technical Features**

<p><b>MATERIALE:</b></p>	<p><b>MATERIAL:</b></p>	<p><b>OPENABLE</b></p>
<p>pressofusione di alluminio, vetro.</p>	<p>die-cast aluminium, glass.</p>	<p>Apparecchio apribile e rigenerabile (componentistica interna sostituibile) con l'utilizzo di utensili. <i>Openable fixture with basic tools - Replaceable internal components using basic tools.</i></p>
<p><b>TEMPERATURA DI COLORE // COLOUR TEMPERATURE</b></p>		<p><b>TIPO DI FISSAGGIO // FIXING TYPE</b></p>
<p>2200K // 3000K // 4000K // 5700K</p>		
<p><b>DIMMERABILE // DIMMABLE</b></p>		<p><b>TESTA-PALO // POLE-TOP</b></p>
<p><b>SISTEMI OTTICI // OPTICAL SYSTEMS</b></p>		<p><b>LATERALE // SIDE</b></p>
		<p>Regolabile con step da 5° <i>Adjustable with 5° steps</i></p> <p>Regolabile con step da 5° <i>Adjustable with 5° steps</i></p>
<p>• TYPE 2 •    • TYPE 3 •    • TYPE 4 •    • TYPE 5 •</p>		<p>+20°</p> <p>+10° -20°</p>





**VIRGO C 400**

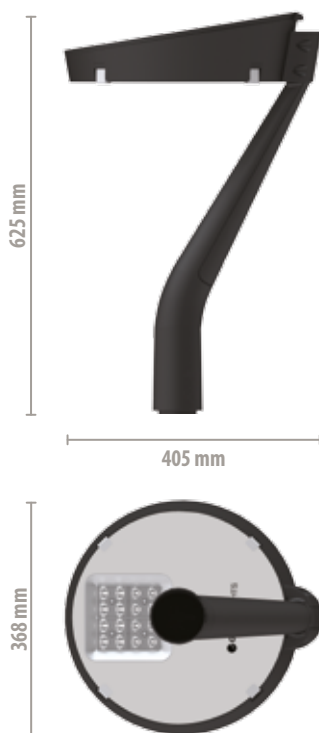

**VC4  
GLASSED**

**Specifiche Tecniche // Technical Features**

<b>MATERIALE:</b>	<b>MATERIAL:</b>	<b>OPENABLE</b>
pressofusione di alluminio, vetro.	die-cast aluminium, glass.	Apparecchio apribile e rigenerabile (componentistica interna sostituibile) con l'utilizzo di utensili. <i>Openable fixture with basic tools - Replaceable internal components using basic tools.</i>
<b>TEMPERATURA DI COLORE // COLOUR TEMPERATURE</b>		<b>TIPO DI FISSAGGIO // FIXING TYPE</b>
2200K // 3000K // 4000K // 5700K		
<b>DIMMERABILE // DIMMABLE</b>		<b>TESTA-PALO // POLE-TOP</b>
<b>SISTEMI OTTICI // OPTICAL SYSTEMS</b>		

**illuminazione di arredo urbano contemporaneo //**  
*contemporary urban lighting*

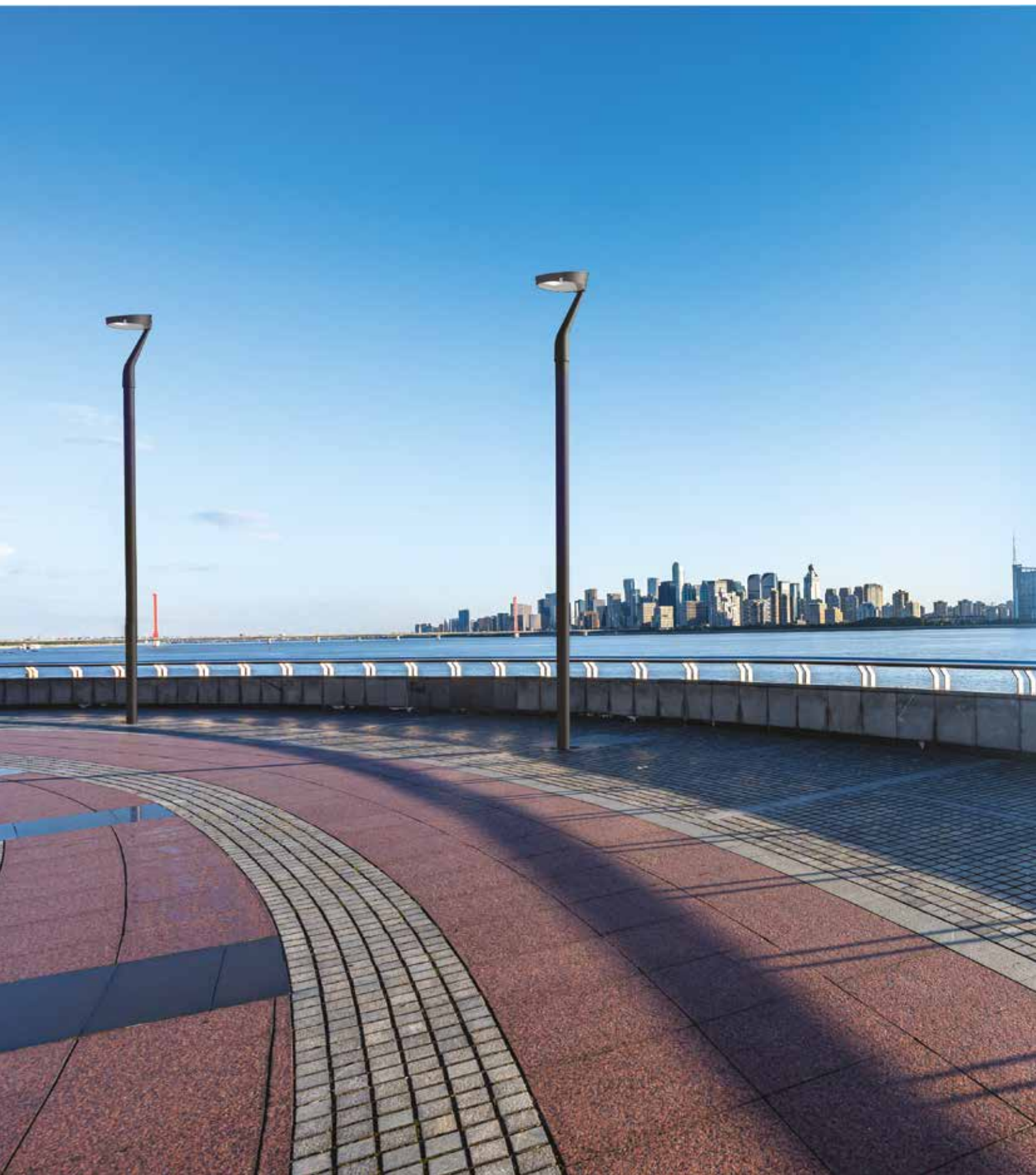



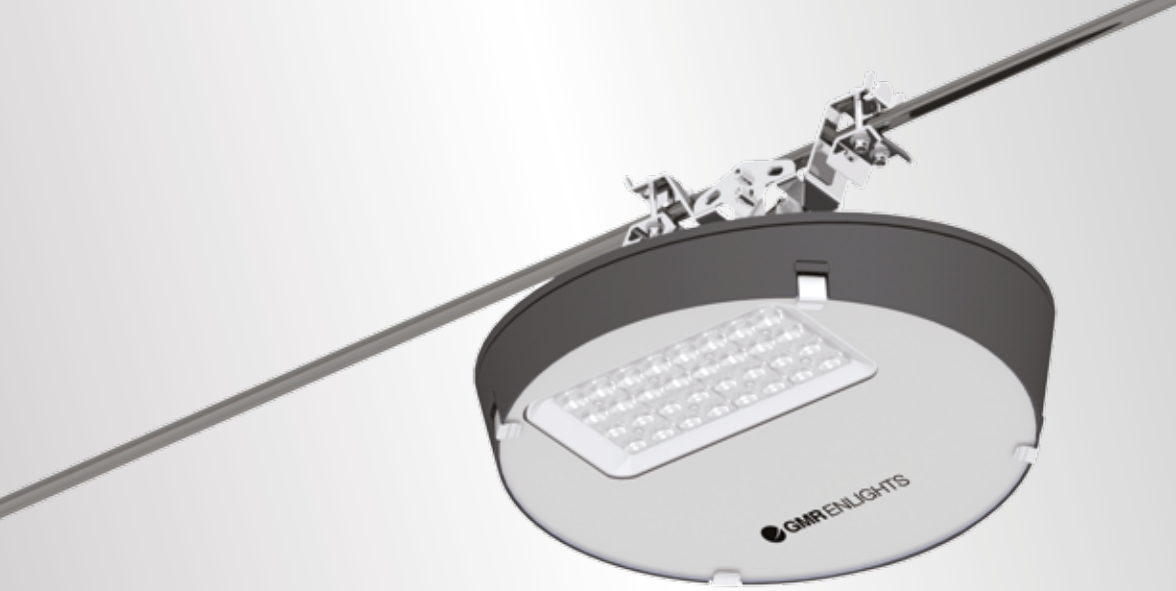



**VIRGO A 500**

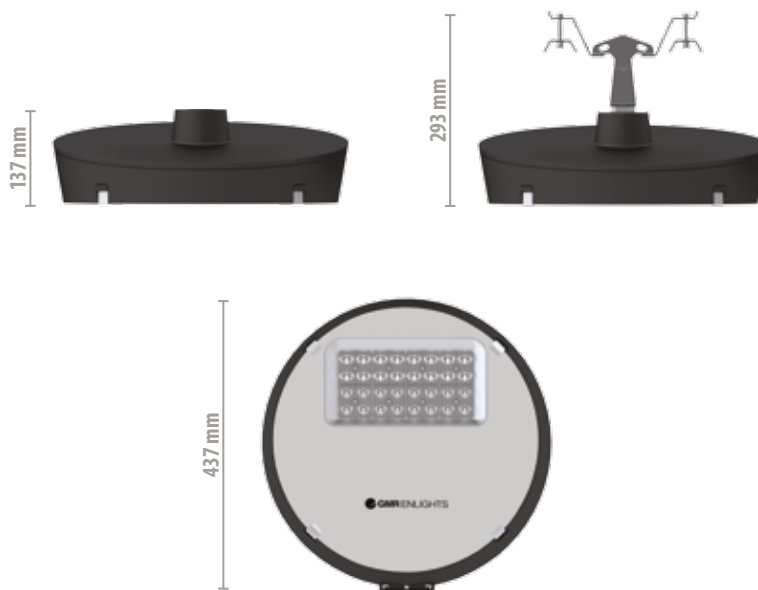

**VA5  
GLASSED**

**Specifiche Tecniche // Technical Features**

<p><b>MATERIALE:</b></p>	<p><b>MATERIAL:</b></p>	<p><b>OPENABLE</b></p>
<p>pressofusione di alluminio, vetro.</p>	<p>die-cast aluminium, glass.</p>	<p>Apparecchio apribile e rigenerabile (componentistica interna sostituibile) con l'utilizzo di utensili. <i>Openable fixture with basic tools - Replaceable internal components using basic tools.</i></p>
<p><b>TEMPERATURA DI COLORE // COLOUR TEMPERATURE</b></p>		<p><b>TIPO DI FISSAGGIO // FIXING TYPE</b></p>
<p>2200K // 3000K // 4000K // 5700K</p>		
<p><b>DIMMERABILE // DIMMABLE</b></p>		<p><b>SOSPENSIONE // SUSPENDED</b>      <b>TESATA DI FUNE // WIRE SYSTEM</b></p>
<p><b>SISTEMI OTTICI // OPTICAL SYSTEMS</b></p>		
<p>• TYPE 1 •    • TYPE 2 •    • TYPE 3 •    • TYPE 4 •    • TYPE 5 •</p>		





**VIRGO B 500**

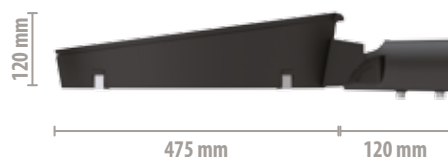

**VB5  
GLASSED**

**Specifiche Tecniche // Technical Features**

<b>MATERIALE:</b>	<b>MATERIAL:</b>	<b>OPENABLE</b>	
pressofusione di alluminio, vetro.	die-cast aluminium, glass.	Apparecchio apribile e rigenerabile (componentistica interna sostituibile) con l'utilizzo di utensili. <i>Openable fixture with basic tools - Replaceable internal components using basic tools.</i>	
<b>TEMPERATURA DI COLORE // COLOUR TEMPERATURE</b>		<b>TIPO DI FISSAGGIO // FIXING TYPE</b>	
2200K // 3000K // 4000K // 5700K			
<b>DIMMERABILE // DIMMABLE</b>		<b>TESTA-PALO // POLE-TOP</b>	
<b>SISTEMI OTTICI // OPTICAL SYSTEMS</b>		Regolabile con step da 5° <i>Adjustable with 5° steps</i> 	<b>LATERALE // SIDE</b> Regolabile con step da 5° <i>Adjustable with 5° steps</i> 
• TYPE 2 •	• TYPE 3 •	• TYPE 4 •	• TYPE 5 •



**VIRGO C 500**



**VC5  
GLASSED**

**Specifiche Tecniche // Technical Features**

<p><b>MATERIALE:</b> pressofusione di alluminio, vetro.</p>	<p><b>MATERIAL:</b> die-cast aluminium, glass.</p>	<p><b>OPENABLE</b> Apparecchio apribile e rigenerabile (componentistica interna sostituibile) con l'utilizzo di utensili. <i>Openable fixture with basic tools - Replaceable internal components using basic tools.</i></p>
<p><b>TEMPERATURA DI COLORE // COLOUR TEMPERATURE</b> 2200K // 3000K // 4000K // 5700K</p>		<p><b>TIPO DI FISSAGGIO // FIXING TYPE</b></p>
<p><b>DIMMERABILE // DIMMABLE</b></p>		
<p><b>SISTEMI OTTICI // OPTICAL SYSTEMS</b></p>		<p><b>TESTA-PALO // POLE-TOP</b></p>
<p>• TYPE 2 •    • TYPE 3 •    • TYPE 4 •    • TYPE 5 •</p>		

**illuminazione di arredo urbano contemporaneo //**  
*contemporary urban lighting*









**Illuminazione di arredo  
urbano contemporaneo //**  
*contemporary urban lighting*

**CORPI ILLUMINANTI // *lighting fixtures***

194

**HULLA**

196

**HULLA MODULE COMBINING**

**PALI // *poles***

200

**HULLA REGOLO POLE**

**MENSOLE A MURO // *wall brackets***

202

**HULLA REGOLO WALL BRACKET**

**TOTEM // *totems***

206

**HULLA ELIO TOTEM**

**BOLLARD // *bollards***

208

**HULLA GEO BOLLARD**

212

**HULLA ZENO BOLLARD**

**WALL WASHER**

216

**HULLA WALL WASHER**

# H u l l a

La semplicità di una linea di luce: Hulla.

*Simplicity in a line of light: Hulla.*

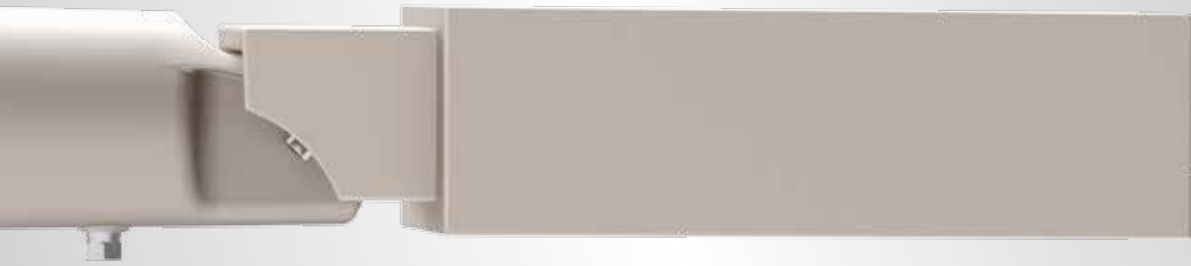

**HULLA**

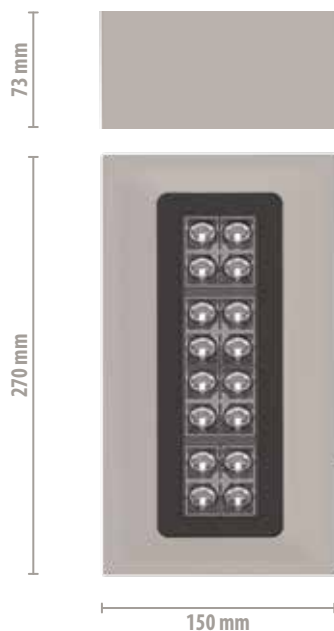

**HMC  
GLASSED**

**Specifiche Tecniche // Technical Features**

<p><b>MATERIALE:</b> trafila di alluminio, pressofusione di alluminio, vetro.</p>	<p><b>MATERIAL:</b> extruded aluminium, die-cast aluminium, glass.</p>	<p><b>COMPACT</b> Apparecchio sigillato, fornito con connettore rapido per installazione immediata. <i>Sealed fixture with short power cable and IP electrical connector for a quick and simple linkage to the mains.</i></p>								
<p><b>TEMPERATURA DI COLORE // COLOUR TEMPERATURE</b> 3000K // 4000K // 5700K</p>		<p><b>TIPO DI FISSAGGIO // FIXING TYPE</b></p>								
<p><b>DIMMERABILE // DIMMABLE</b></p>		<table border="1"> <tr> <td data-bbox="815 1493 1050 1669"> <p><b>TESTA-PALO // POLE-TOP</b> Regolabile con step da 5° <i>Adjustable with 5° steps</i></p> <p>+15°</p> </td> <td data-bbox="1050 1493 1310 1669"> <p><b>LATERALE // SIDE</b> Regolabile con step da 5° <i>Adjustable with 5° steps</i></p> <p>+ 5° -15°</p> </td> <td data-bbox="1310 1493 1532 1669"> <p><b>A PARETE // WALL-MOUNTED</b></p> </td> </tr> </table>	<p><b>TESTA-PALO // POLE-TOP</b> Regolabile con step da 5° <i>Adjustable with 5° steps</i></p> <p>+15°</p>	<p><b>LATERALE // SIDE</b> Regolabile con step da 5° <i>Adjustable with 5° steps</i></p> <p>+ 5° -15°</p>	<p><b>A PARETE // WALL-MOUNTED</b></p>					
<p><b>TESTA-PALO // POLE-TOP</b> Regolabile con step da 5° <i>Adjustable with 5° steps</i></p> <p>+15°</p>	<p><b>LATERALE // SIDE</b> Regolabile con step da 5° <i>Adjustable with 5° steps</i></p> <p>+ 5° -15°</p>	<p><b>A PARETE // WALL-MOUNTED</b></p>								
<p><b>SISTEMI OTTICI // OPTICAL SYSTEMS</b></p>										
<table border="1"> <tr> <td data-bbox="304 1689 416 1764"></td> <td data-bbox="416 1689 528 1764"></td> <td data-bbox="528 1689 639 1764"></td> <td data-bbox="639 1689 783 1764"></td> </tr> <tr> <td>• TYPE 2 •</td> <td>• TYPE 3 •</td> <td>• TYPE 4 •</td> <td>• TYPE 5 •</td> </tr> </table>						• TYPE 2 •	• TYPE 3 •	• TYPE 4 •	• TYPE 5 •	
• TYPE 2 •	• TYPE 3 •	• TYPE 4 •	• TYPE 5 •							

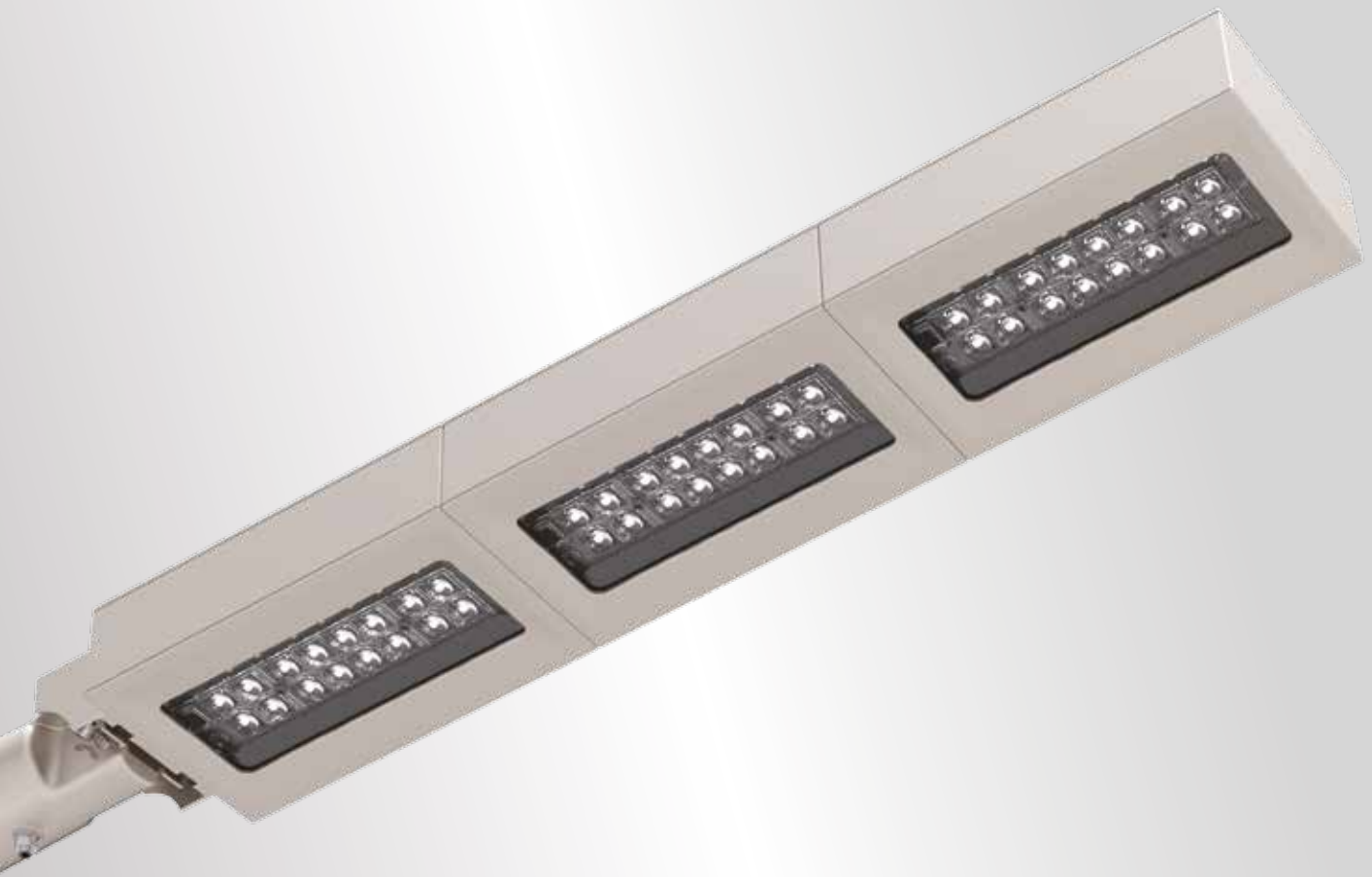

## HULLA MODULE COMBINING

“Hulla” è un corpo illuminante concepito nell’ottica della flessibilità. Può essere combinato in soluzioni lineari fino ad un massimo di tre moduli, in funzione della geometria di installazione. “Hulla” può essere installato in qualsiasi tipo di palo o mensola grazie allo snodo regolabile.

*Flexibility is the main source of inspiration for Hulla. It can be combined in linear solutions with maximum three modules according to the type of installation. “Hulla” can be installed in all types of pole or bracket by means of the adjustable joint.*

### Soluzioni Modulari // Modular Solutions

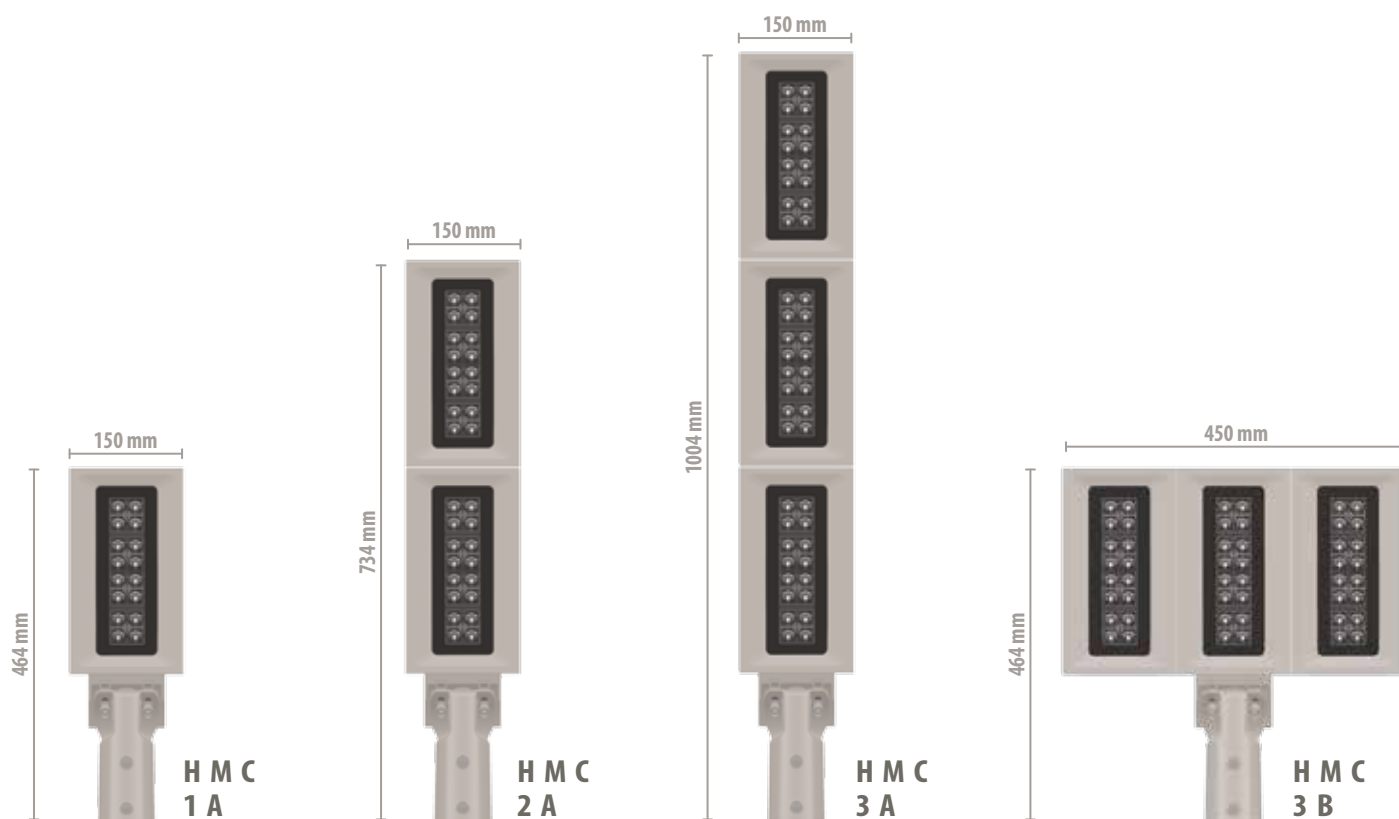



**illuminazione di arredo urbano contemporaneo //**  
*contemporary urban lighting*









## HULLA REGOLO POLE

“Hulla Regolo” è una collezione di pali in acciaio a sezione rettangolare. Disponibili in più altezze e con numero variabile di moduli luminosi.

*“Hulla Regolo” is a collection of steel poles with a rectangular shaft. Available in different heights with customisable number of LED modules.*

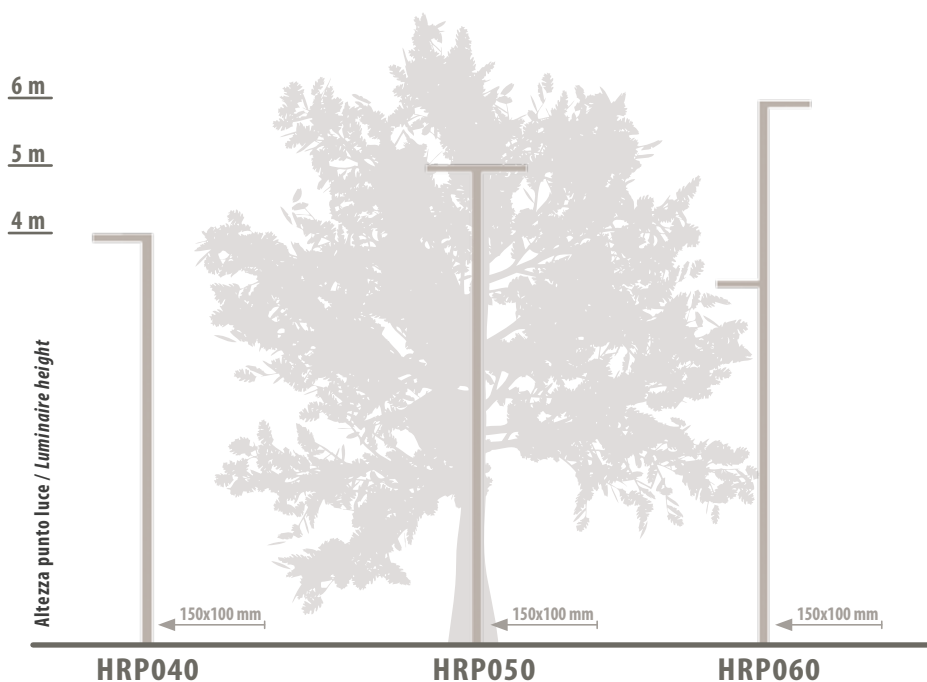

### Versioni Disponibili // Available Versions

HRP040 - HRP050 mensola singola o doppia / HRP040 - HRP050 single or double arm

HRP060 mensola singola, doppia o sfalsata / HRP060 single, double or split-level arm

Tipo di fissaggio: flangia o fondazione / Fixing type: flange or foundation

### Soluzioni Modulari // Modular Solutions

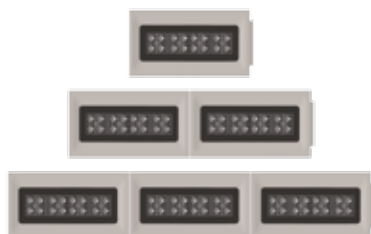

Configurabile per ogni altezza come riportato in figura.  
Configurable for any height as shown in the figure.

### Sbraccio // Extension

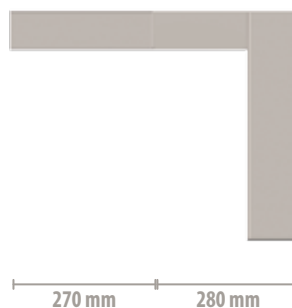



## HULLA REGOLO WALL BRACKET

La mensola a muro "Hulla Regolo" completa la collezione di pali, riprendendone la linea e lo stile. Disponibile in un'unica versione e con un numero differente di moduli luminosi in funzione della geometria di installazione.

*"Hulla Regolo" wall bracket completes the pole collection with a coordinated line and style. Only available in one version with either one or two LED modules.*

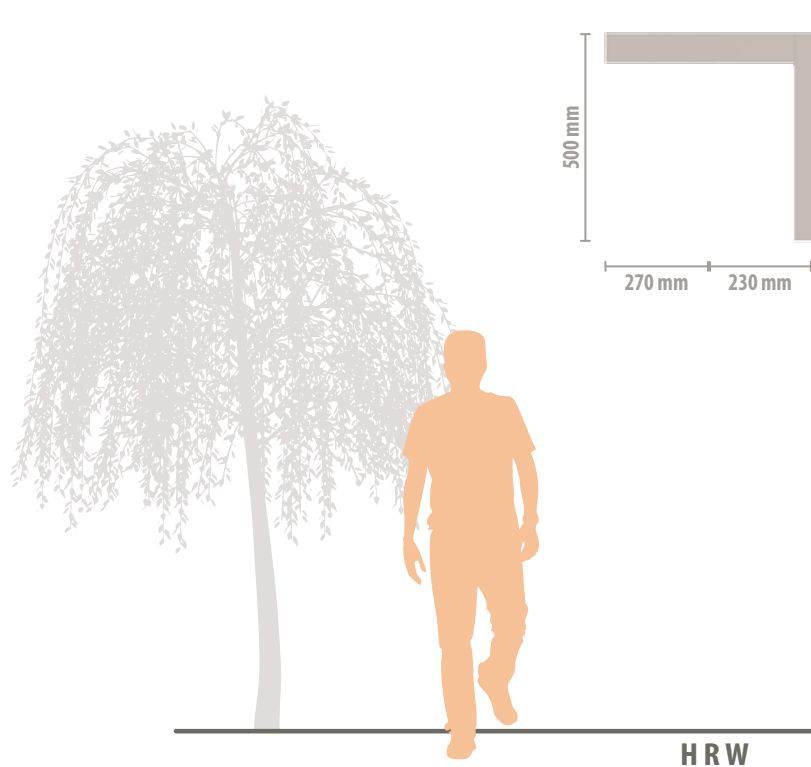

### Soluzioni Modulari // Modular Solutions

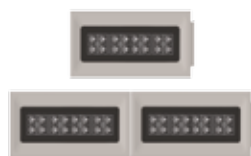

Configurabile come riportato in figura.  
*Configurable as shown in the figure.*



**illuminazione di arredo urbano contemporaneo //**  
*contemporary urban lighting*







## HULLA ELIO TOTEM

“Hulla Elio” è un sistema di illuminazione lineare ed elegante. Il sostegno è realizzato in acciaio con finiture di precisione. Applicabile in contesti sia urbani che privati.

*“Hulla Elio” totem is an elegant linear lighting system. The support is made of steel with very accurate finishes. Suitable for application both in urban and residential solutions.*



### Versioni Disponibili // Available Versions

Totem singolo o doppio / Single or double totem

Tipo di fissaggio: flangia o fondazione / Fixing type: flange or foundation





## HULLA GEO BOLLARD

Il bollard "Hulla Geo" offre un'ampia possibilità di impiego in vari campi dell'arredo per esterni. Una delle caratteristiche principali del bollard è la possibilità di orientare la sorgente luminosa a 360°.

*"Hulla Geo" bollard offers a wide range of applications in multiple outdoor furniture sectors. One of its main features is the 360° orientation of the light source.*

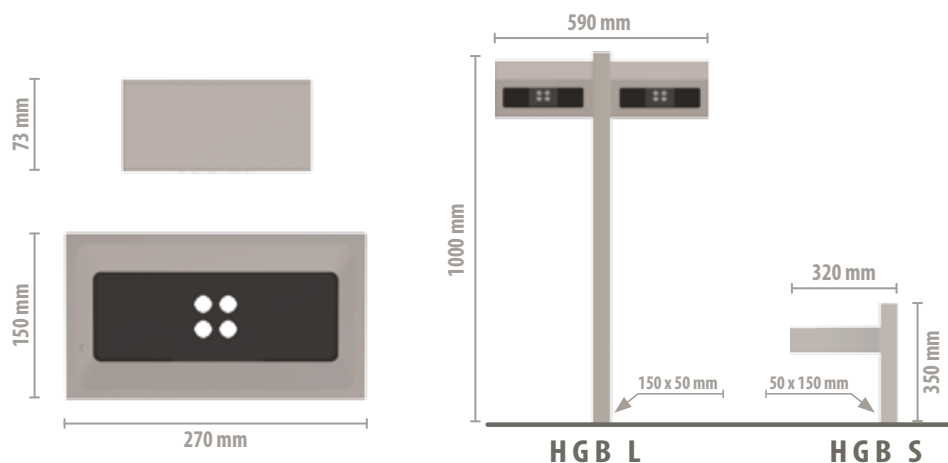

### Specifiche Tecniche // Technical Features

<p><b>MATERIALE:</b></p> <p><b>Corpo:</b> trafilata di alluminio, pressofusione di alluminio, vetro. <b>Sostegno:</b> acciaio.</p>	<p><b>MATERIAL:</b></p> <p><b>Body:</b> extruded aluminium, die-cast aluminium, glass. <b>Support:</b> steel.</p>	<p><b>COMPACT</b></p> <p>Apparecchio sigillato, fornito con connettore rapido per installazione immediata. <i>Sealed fixture with short power cable and IP electrical connector for a quick and simple linkage to the mains.</i></p>
<p><b>TEMPERATURA DI COLORE // COLOUR TEMPERATURE</b></p> <p>3000K // 4000K // 5700K</p>	<p><b>TIPO DI FISSAGGIO // FIXING TYPE</b></p>	
<p><b>DIMMERABILE // DIMMABLE</b></p>		
<p><b>SISTEMI OTTICI // OPTICAL SYSTEMS</b></p>	<p><b>FLANGIA // FLANGE</b></p>	<p><b>PICCHETTO // EARTH SPIKE</b></p>
<p><b>MONODIREZIONALE // UNIDIRECTIONAL</b></p>		
<p><b>Modulo Luminoso Regolabile di 360°</b> <i>360° adjustable luminous module</i></p>		



**illuminazione di arredo urbano contemporaneo //**  
*contemporary urban lighting*









## HULLA ZENO BOLLARD

Il bollard "Hulla Zeno" offre un'ampia possibilità di impiego in vari contesti di arredo urbano.

*"Hulla Zeno" bollard offers a wide range of applications in multiple urban furniture solutions.*

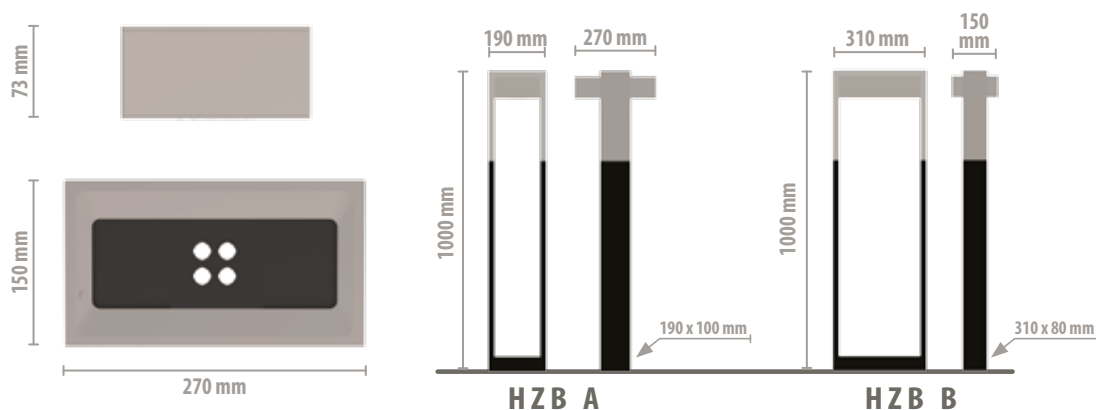

### Specifiche Tecniche // Technical Features

<p><b>MATERIALE:</b></p> <p><b>Corpo:</b> trafilata di alluminio, pressofusione di alluminio, vetro. <b>Sostegno:</b> acciaio.</p>	<p><b>MATERIAL:</b></p> <p><b>Body:</b> extruded aluminium, die-cast aluminium, glass. <b>Support:</b> steel.</p>	<p><b>COMPACT</b></p> <p>Apparecchio sigillato, fornito con connettore rapido per installazione immediata. <i>Sealed fixture with short power cable and IP electrical connector for a quick and simple linkage to the mains.</i></p>
<p><b>TEMPERATURA DI COLORE // COLOUR TEMPERATURE</b></p> <p>3000K // 4000K // 5700K</p>		<p><b>TIPO DI FISSAGGIO // FIXING TYPE</b></p> <div style="display: flex; justify-content: space-around;"> <div data-bbox="815 1493 1046 1669"> <p><b>FLANGIA // FLANGE</b></p> </div> <div data-bbox="1046 1493 1286 1669"> <p><b>PICCHETTO // EARTH SPIKE</b></p> </div> </div>
<p><b>DIMMERABILE // DIMMABLE</b></p>		
<p><b>SISTEMI OTTICI // OPTICAL SYSTEMS</b></p> <div style="display: flex; justify-content: space-around;"> <div data-bbox="427 1689 539 1796"> <p>• 7 •</p> </div> <div data-bbox="547 1689 659 1796"> <p>• 8 •</p> </div> </div>		



**illuminazione di arredo urbano contemporaneo //**  
*contemporary urban lighting*











## HULLA WALL WASHER

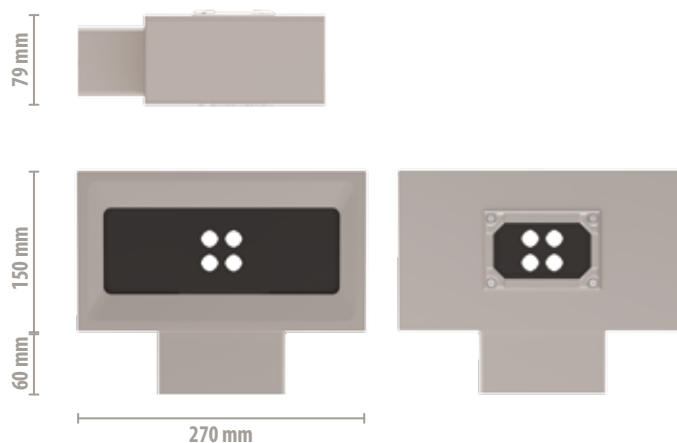

Il Wall Washer "Hulla" rappresenta la versione a parete della collezione. Si presta per una molteplicità di soluzioni architettoniche, sia urbane che private.

*"Hulla" wall washer is the wall-mounted version of the Hulla collection. It is suitable for both urban and residential architectural solutions.*

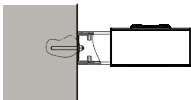

**H W W**

### Specifiche Tecniche // Technical Features

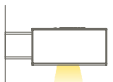
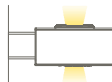
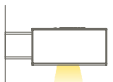
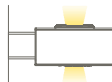
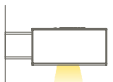
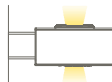
<p><b>MATERIALE:</b> Corpo: trafilata di alluminio, pressofusione di alluminio, vetro. Supporto a muro: acciaio.</p>	<p><b>MATERIAL:</b> Body: extruded aluminium, die-cast aluminium, glass. Wall-mounted support: steel.</p>	<p><b>COMPACT</b> Apparecchio sigillato, fornito con connettore rapido per installazione immediata. <i>Sealed fixture with short power cable and IP electrical connector for a quick and simple linkage to the mains.</i></p>		
<p><b>TEMPERATURA DI COLORE // COLOUR TEMPERATURE</b> 3000K // 4000K // 5700K</p>		<p><b>TIPO DI FISSAGGIO // FIXING TYPE</b></p>		
<p><b>DIMMERABILE // DIMMABLE</b></p>		<p> <b>A PARETE // WALL-MOUNTED</b></p>		
<p><b>SISTEMI OTTICI // OPTICAL SYSTEMS</b></p> <p></p>		<table border="1"> <tr> <td data-bbox="815 1675 1054 1806"> <p> <b>MONODIREZIONALE // UNIDIRECTIONAL</b></p> </td> <td data-bbox="1054 1675 1286 1806"> <p> <b>BIDIREZIONALE // BIDIRECTIONAL</b></p> </td> </tr> </table>	<p> <b>MONODIREZIONALE // UNIDIRECTIONAL</b></p>	<p> <b>BIDIREZIONALE // BIDIRECTIONAL</b></p>
<p> <b>MONODIREZIONALE // UNIDIRECTIONAL</b></p>	<p> <b>BIDIREZIONALE // BIDIRECTIONAL</b></p>			

**illuminazione di arredo urbano contemporaneo //**  
*contemporary urban lighting*







**Illuminazione di arredo  
urbano contemporaneo //**  
*contemporary urban lighting*

**CORPI ILLUMINANTI // *lighting fixtures***

222 **ESA**

224 **ESA MODULE COMBINING**

**PALI // *poles***

228 **ESA TRIAL POLE**

234 **ESA ARCO POLE**

236 **ESA ARCO POLE ARM**

240 **ESA PRISMA POLE**

242 **ESA PRISMA POLE ARM**

**MENSOLE A MURO // *wall brackets***

230 **ESA TRIAL WALL BRACKET**

**BOLLARD // *bollards***

246 **ESA SPILLO, ESA ORFEO BOLLARD**

**WALL WASHER**

248 **ESA WALL WASHER**



# E s a

Un'idea ispirata alla geometrica armonia delle forme naturali: Esa è in grado, con la sua essenziale regolarità, di generare un pattern di luce potenzialmente infinito.

*An idea inspired by the geometrical harmony of natural shapes. With its essential regularity, Esa creates a potentially endless light pattern.*

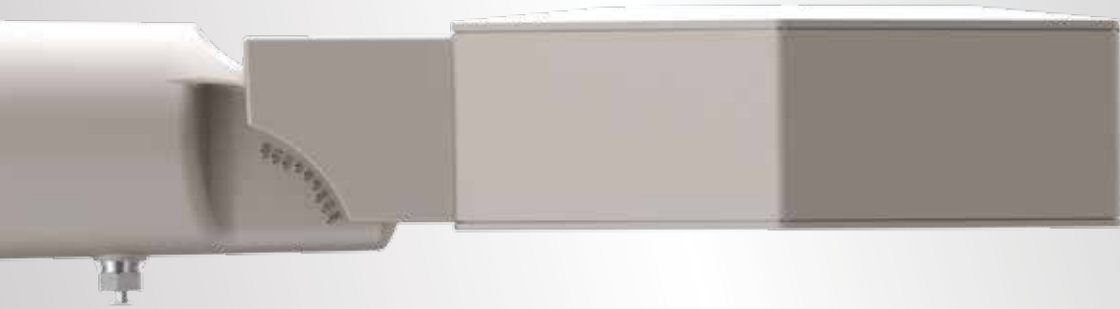

**ESA**

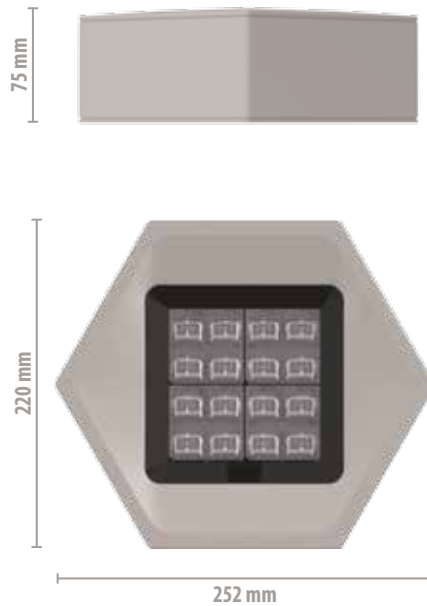

**EMC  
GLASSED**

**Specifiche Tecniche // Technical Features**

<p><b>MATERIALE:</b></p> <p>trafila di alluminio, pressofusione di alluminio, vetro.</p>	<p><b>MATERIAL:</b></p> <p>extruded aluminium, die-cast aluminium, glass.</p>	<p><b>COMPACT</b></p> <p>Apparecchio sigillato, fornito con connettore rapido per installazione immediata. <i>Sealed fixture with short power cable and IP electrical connector for a quick and simple linkage to the mains.</i></p>		
<p><b>TEMPERATURA DI COLORE // COLOUR TEMPERATURE</b></p> <p>3000K // 4000K // 5700K</p>		<p><b>TIPO DI FISSAGGIO // FIXING TYPE</b></p>		
<p><b>DIMMERABILE // DIMMABLE</b></p>				
<p><b>SISTEMI OTTICI // OPTICAL SYSTEMS</b></p>		<p><b>TESTA-PALO // POLE-TOP</b></p>	<p><b>LATERALE // SIDE</b></p>	<p><b>A PARETE // WALL-MOUNTED</b></p>
<p>• TYPE 2 •   • TYPE 3 •   • TYPE 4 •   • TYPE 5 •</p>		<p>Regolabile con step da 5° <i>Adjustable with 5° steps</i></p> <p>+15°</p>	<p>Regolabile con step da 5° <i>Adjustable with 5° steps</i></p> <p>+ 5° -15°</p>	



## ESA MODULE COMBINING

“Esa” è un corpo illuminante concepito nell’ottica della flessibilità. Grazie alla forma geometrica regolare può essere combinato in più soluzioni, fino ad un massimo di tre moduli, in funzione del tipo di installazione. “Esa” può essere installato in qualsiasi tipo di palo o di mensola grazie all’apposito snodo regolabile.

*Flexibility is the main source of inspiration for “Esa”. Thanks to its regular geometrical shape it can be combined in multiple solutions with maximum three modules according to the type of installation. “Esa” can be installed in all types of poles or brackets by means of the adjustable joint.*

### Soluzioni Modulari // Modular Solutions

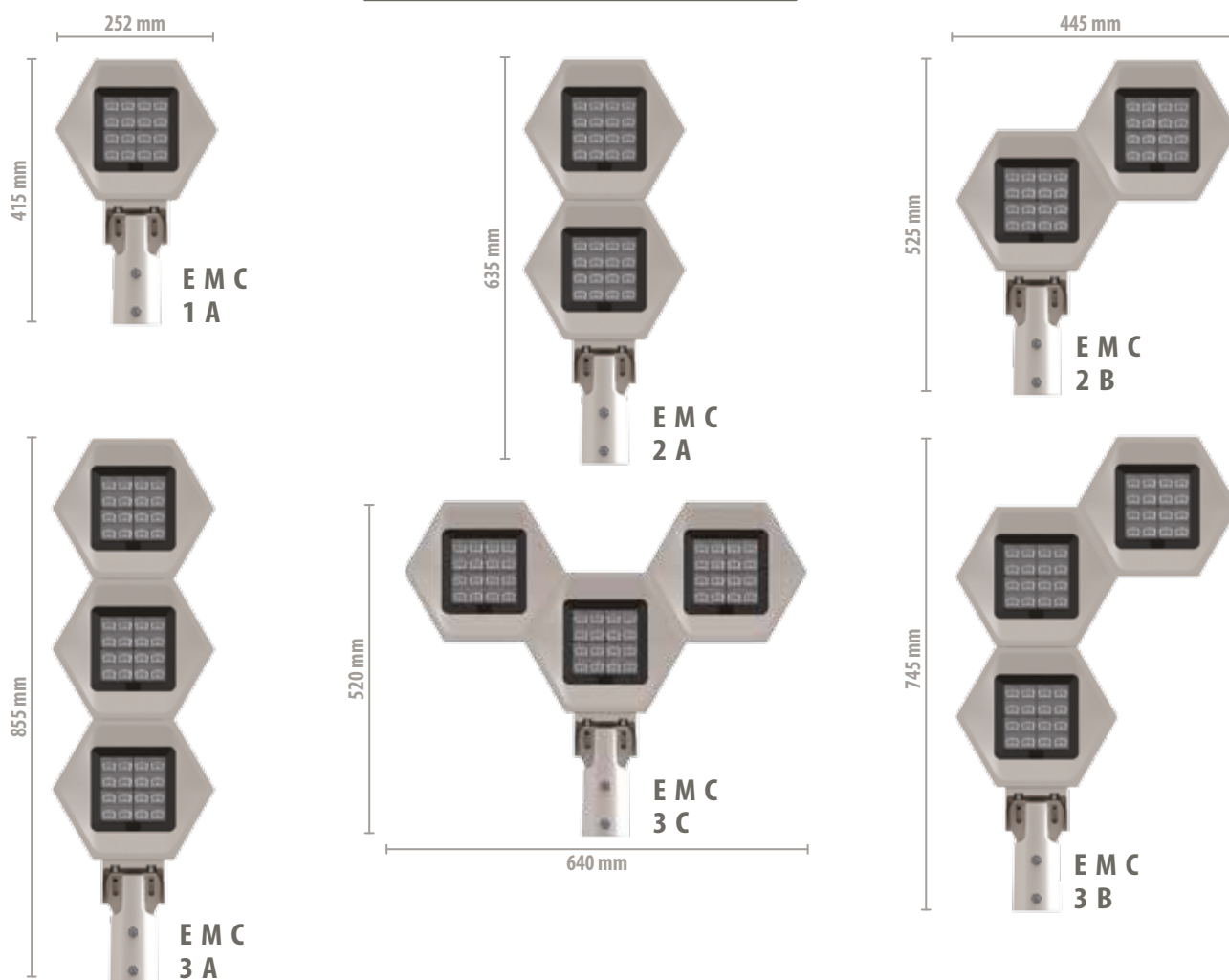



**illuminazione di arredo urbano contemporaneo //**  
*contemporary urban lighting*









## ESA TRIAL POLE

“Esa Trial” è una collezione di pali in acciaio a sezione trapezoidale. Disponibili in diverse altezze e numero di moduli luminosi.

“Esa Trial” is a collection of steel poles with a trapezoidal shaft. Available in different heights and number of LED modules.

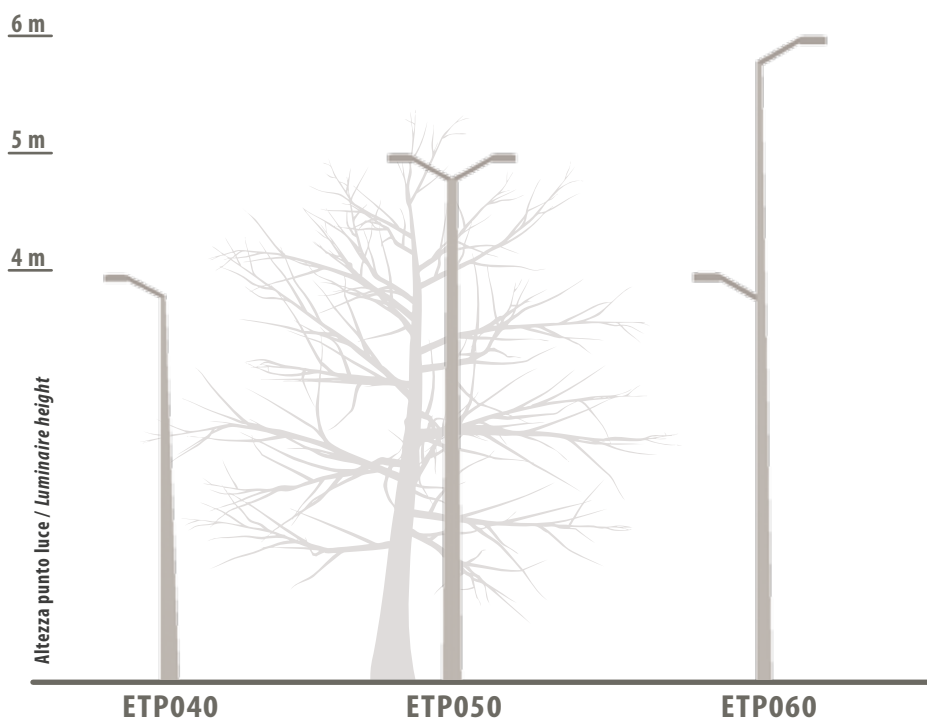

### Versioni Disponibili // Available Versions

ETP040 - ETP050 mensola singola o doppia / ETP040 - ETP050 single or double arm  
 ETP060 mensola singola, doppia o sfalsata / ETP060 single, double or split-level arm  
 Tipo di fissaggio: flangia o fondazione / Fixing type: flange or foundation

### Soluzioni Modulari // Modular Solutions

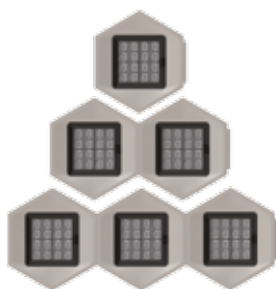

Configurabile per ogni altezza come riportato in figura.  
 Configurable for any height as shown in the figure.

### Sezione palo alla base // Pole section at the base

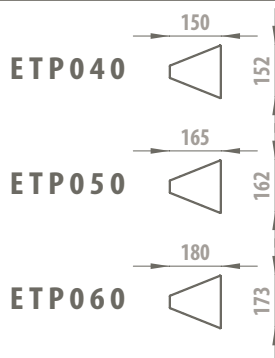

### Sbraccio // Extension

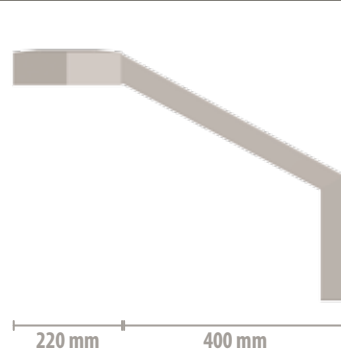





## ESA TRIAL WALL BRACKET

La mensola a muro “Esa Trial” completa la collezione di pali, riprendendone la linea e lo stile. Disponibile in un’unica versione, può essere completata con uno o due moduli luminosi.

*“Esa Trial” wall bracket completes the pole collection with a coordinated line and style. Only available in one version with either one or two LED modules.*

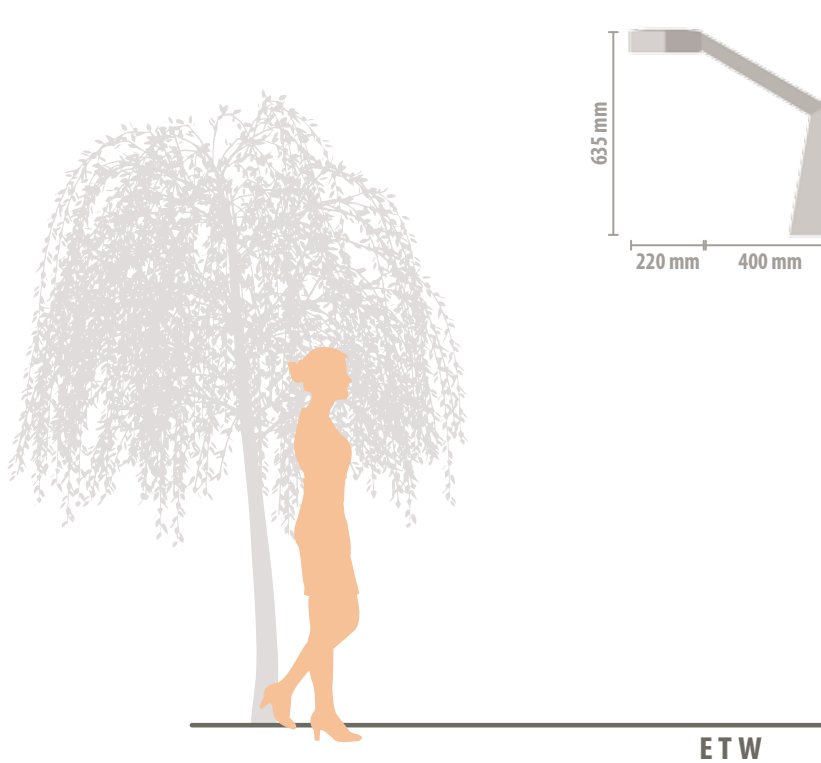

### Soluzioni Modulari // Modular Solutions



Configurabile come riportato in figura.  
Configurable as shown in the figure.

**illuminazione di arredo urbano contemporaneo //**  
*contemporary urban lighting*









## ESA ARCO POLE

“Esa Arco” è appositamente studiato per l’illuminazione di strade e spazi di grandi dimensioni. Il sostegno conico è in acciaio senza saldature a vista. I moduli sono disposti in mensole di acciaio dal design contemporaneo che consentono di direzionare il flusso luminoso senza sovrapposizioni o interferenze dell’emissione luminosa. I moduli possono essere regolati singolarmente a 360° grazie all’apposito snodo.

*“Esa Arco” has been specifically studied to illuminate streets and large areas. It represents a conical support made of steel without visible welding. The modules are disposed on steel shelves with contemporary design that can direct the luminous flux without overlapping or interfering with the luminous emission. They can be individually adjusted by 360° thanks to the specific joint.*

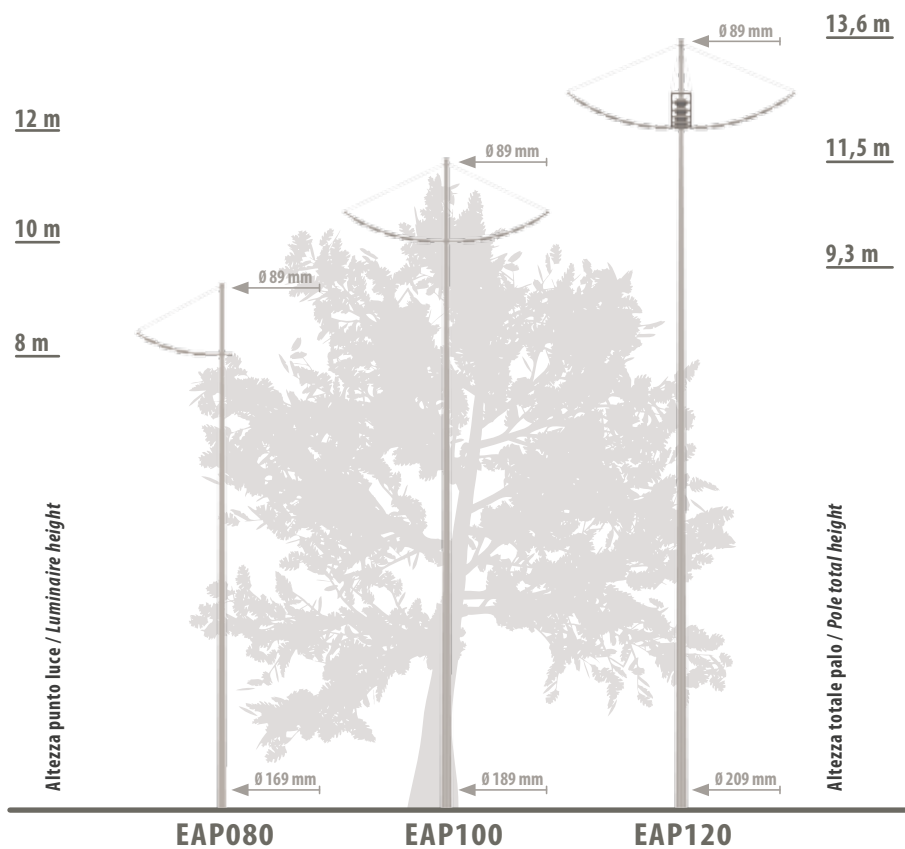

### Versioni Disponibili // Available Versions

Mensola singola, doppia o quadrupla / Single, double or quadruple arm  
 Tipo di fissaggio: flangia o fondazione / Fixing type: flange or foundation





## ESA ARCO POLE ARM

### Specifiche Tecniche // Technical Features

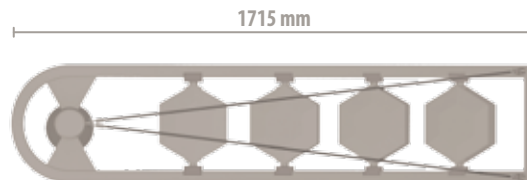

**EAS**

Installabile su palo EAP080 - EAP100 / For installation on pole EAP080 - EAP100

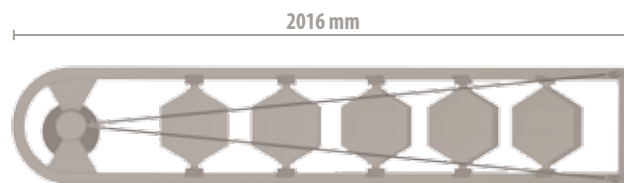

**EAM**

Installabile su palo EAP080 - EAP100 - EAP120 / For installation on pole EAP080 - EAP100 - EAP120

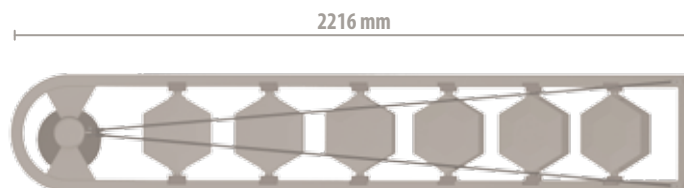

**EAL**

Installabile su palo EAP100 - EAP120 / For installation on pole EAP100 - EAP120



Modulo Luminoso Regolabile di 360°  
360° adjustable LED module

**illuminazione di arredo urbano contemporaneo //**  
*contemporary urban lighting*











## ESA PRISMA POLE

“Esa Prisma” è un sistema complesso studiato appositamente per l’illuminazione di grandi spazi, come ad esempio svincoli, piazze, parcheggi e aree commerciali. Il sostegno conico è in acciaio senza saldature a vista. I singoli moduli, disposti in circonferenza su una corona di acciaio dal design pulito e minimale, consentono di direzionare il fascio luminoso grazie alla regolazione a 180°. I tiranti in acciaio inox conferiscono al sistema un caratteristico aspetto prismatico.

*“Esa Prisma” is a complex system especially developed to illuminate large areas, such as road junctions, squares, parking lots and retail areas. It is a conical support made of steel without visible welding. Each module is arranged on the circumference of a steel crown characterised by a clean and minimal design, with the possibility of directing the luminous flux thanks to a 180° adjustment. The stainless-steel tie rods give a prismatic shape to the system.*

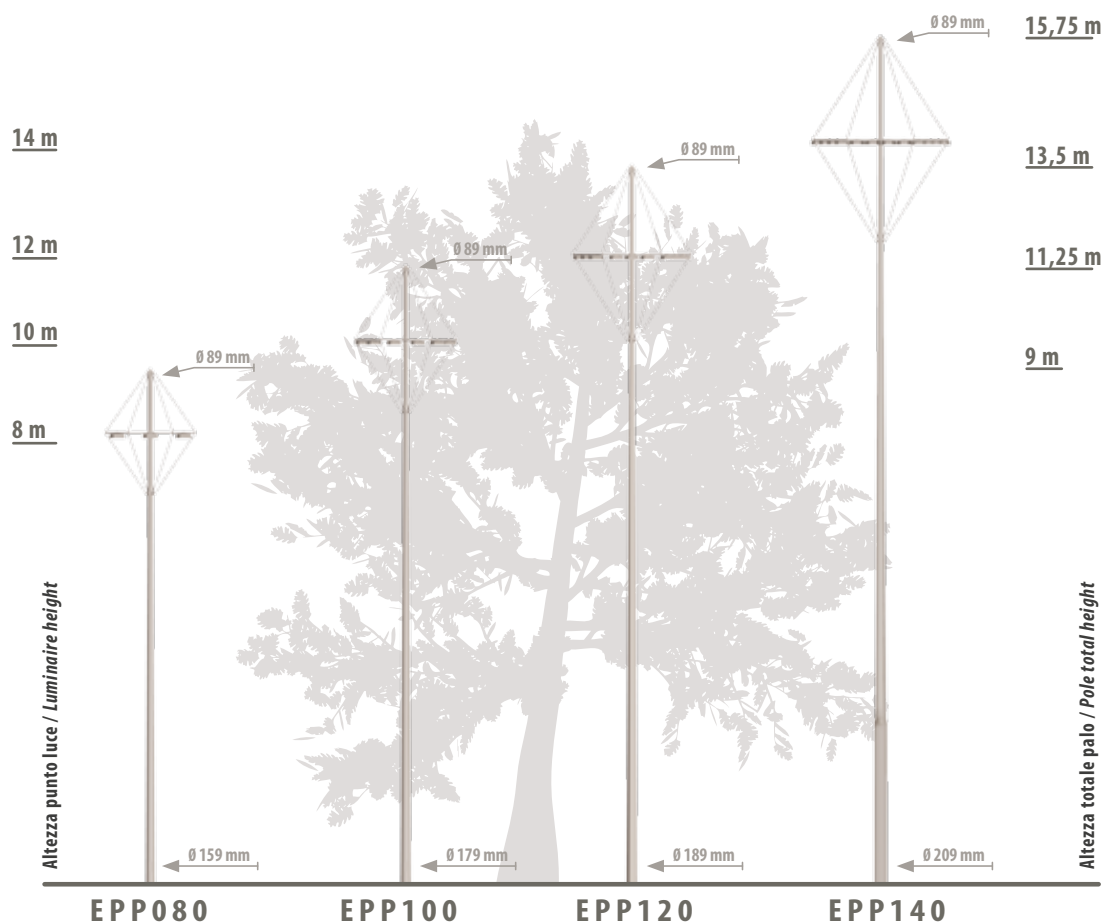

### Versioni Disponibili // Available Versions

Tipo di fissaggio: flangia o fondazione / Fixing type: flange or foundation

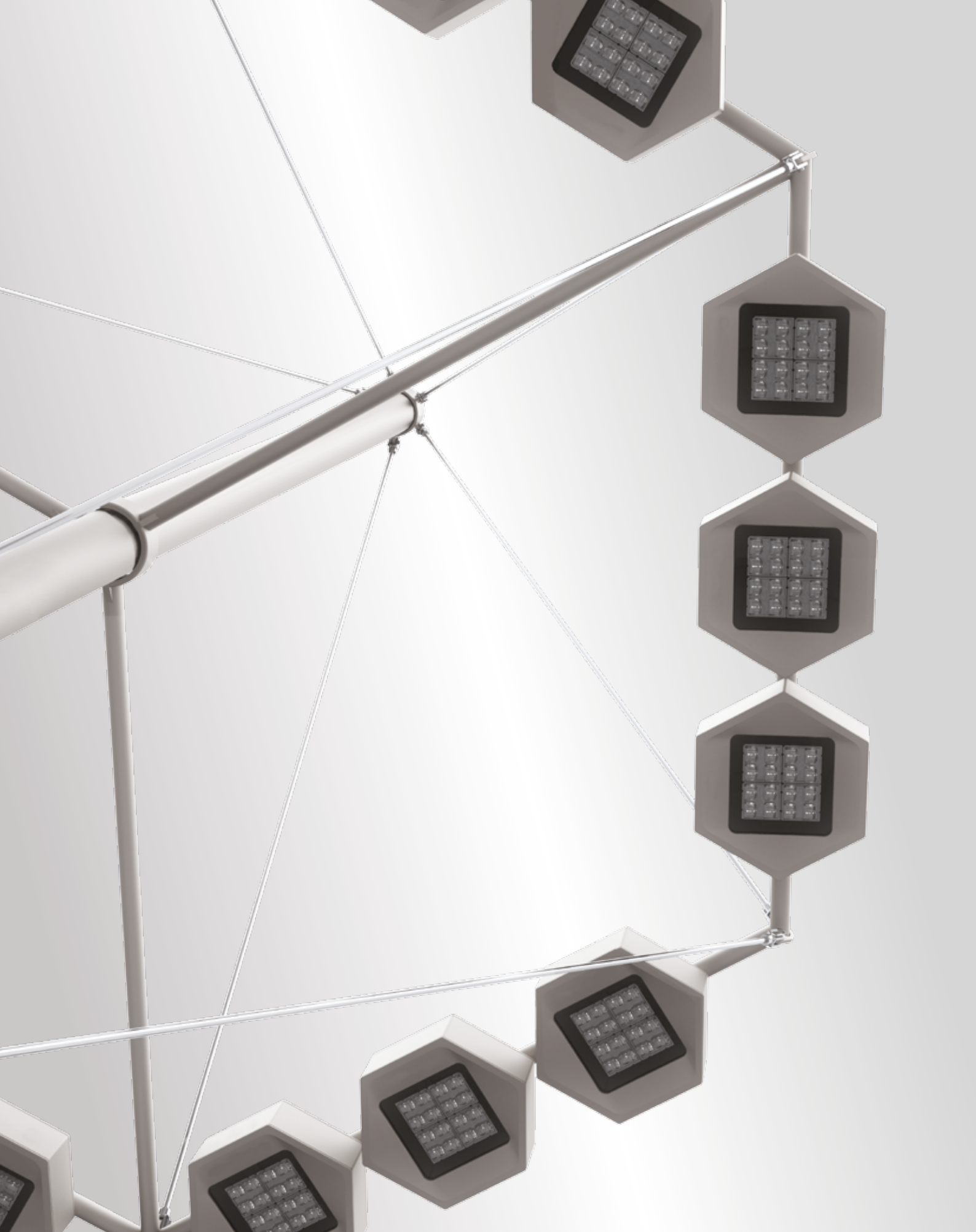

**ESA PRISMA POLE ARM**

**Specifiche Tecniche // Technical Features**

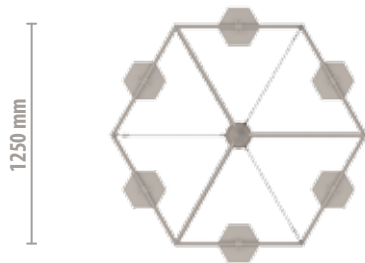

**EPM06**

Installabile su palo EPP080 - EPP100 /  
For installation on pole EPP080 - EPP100

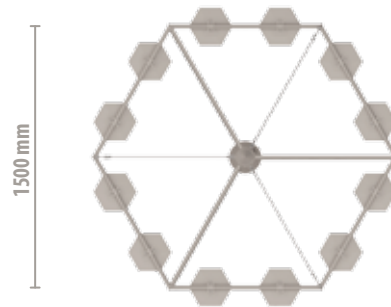

**EPM12**

Installabile su palo EPP080 - EPP100 - EPP120 /  
For installation on pole EPP080 - EPP100 - EPP120

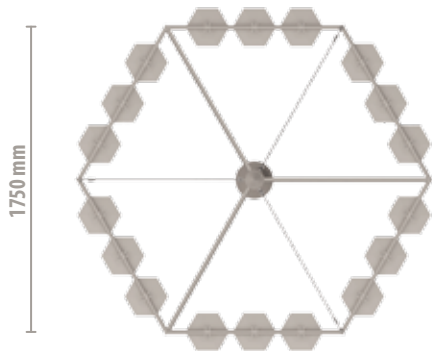

**EPM18**

Installabile su palo EPP100 - EPP120 - EPP140 /  
For installation on pole EPP100 - EPP120 - EPP140

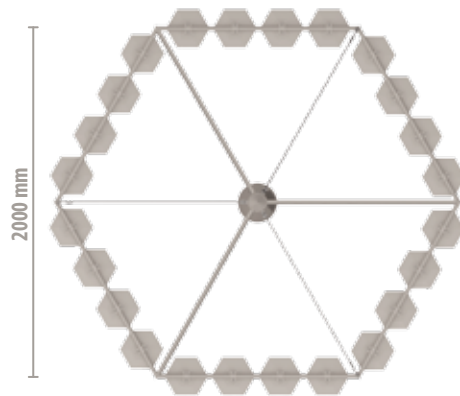

**EPM24**

Installabile su palo EPP120 - EPP140 /  
For installation on pole EPP120 - EPP140



Modulo Luminoso Regolabile di 360°  
360° adjustable LED module



**illuminazione di arredo urbano contemporaneo //**  
*contemporary urban lighting*











## ESA SPILLO, ESA ORFEO BOLLARD

“Esa Spillo” ed “Esa Orfeo” sono bollard eleganti e minimali. Si adattano ad ambiti urbani e privati.

*“Esa Spillo” and “Esa Orfeo” bollard are elegant and minimalist, suitable for both urban and residential applications.*

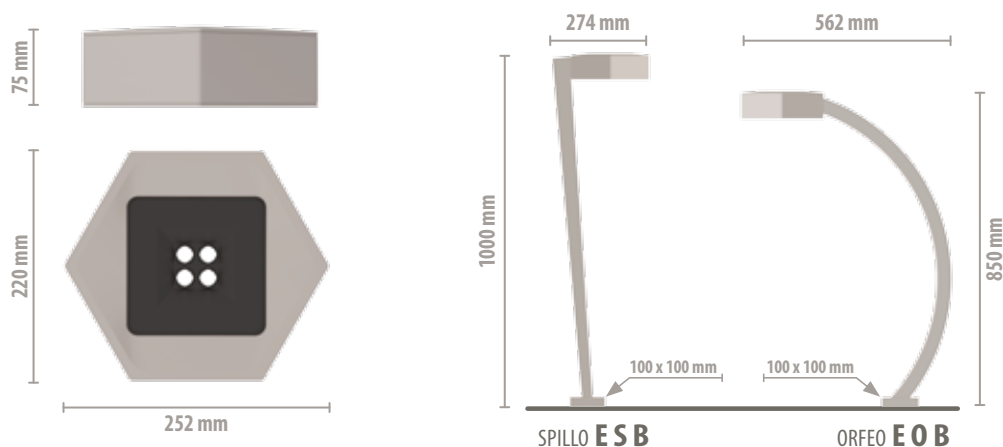

### Specifiche Tecniche // Technical Features

<p><b>MATERIALE:</b></p> <p><b>Corpo:</b> trafilata di alluminio, pressofusione di alluminio, vetro. <b>Sostegno:</b> acciaio.</p>	<p><b>MATERIAL:</b></p> <p><b>Body:</b> extruded aluminium, die-cast aluminium, glass. <b>Support:</b> steel.</p>	<p><b>COMPACT</b></p> <p>Apparecchio sigillato, fornito con connettore rapido per installazione immediata. <i>Sealed fixture with short power cable and IP electrical connector for a quick and simple linkage to the mains.</i></p>	
<p><b>TEMPERATURA DI COLORE // COLOUR TEMPERATURE</b></p> <p>3000K // 4000K // 5700K</p>		<p><b>TIPO DI FISSAGGIO // FIXING TYPE</b></p>	
<p><b>DIMMERABILE // DIMMABLE</b></p>			
<p><b>SISTEMI OTTICI // OPTICAL SYSTEMS</b></p>		<p><b>FLANGIA // FLANGE</b></p>	<p><b>PICCHETTO // EARTH SPIKE</b></p>





## ESA WALL WASHER

Il wall washer "Esa" rappresenta la versione a parete della collezione Esa: si presta per varie soluzioni architettoniche, urbane o private.

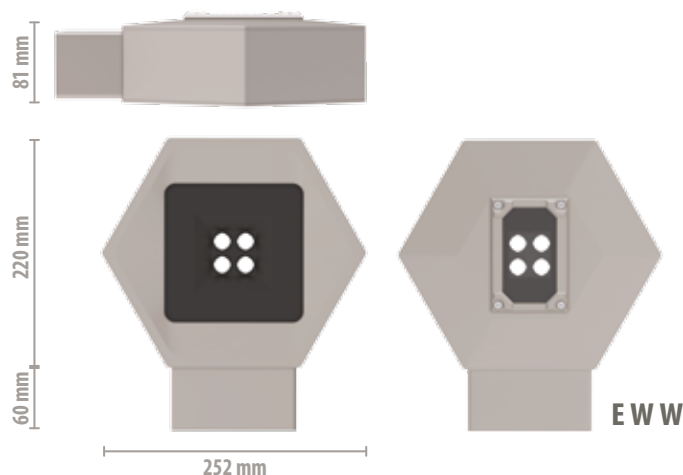
*"Esa" wall washer is the wall-mounted version of the Esa collection. It is suitable for both urban and residential architectural solutions.*

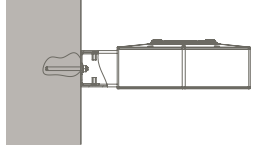
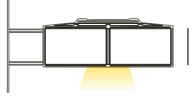
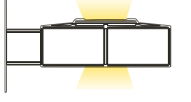

### Specifiche Tecniche // Technical Features

<p><b>MATERIALE:</b></p> <p><b>Corpo:</b> trafilata di alluminio, pressofusione di alluminio, vetro. <b>Supporto a muro:</b> acciaio.</p>	<p><b>MATERIAL:</b></p> <p><b>Body:</b> extruded aluminium, die-cast aluminium, glass. <b>Wall-mounted support:</b> steel.</p>	<p><b>COMPACT</b></p> <p>Apparecchio sigillato, fornito con connettore rapido per installazione immediata. <i>Sealed fixture with short power cable and IP electrical connector for a quick and simple linkage to the mains.</i></p>
<p><b>TEMPERATURA DI COLORE // COLOUR TEMPERATURE</b></p> <p>3000K // 4000K // 5700K</p>		<p><b>TIPO DI FISSAGGIO // FIXING TYPE</b></p> 
<p><b>DIMMERABILE // DIMMABLE</b></p>		<p><b>A PARETE // WALL-MOUNTED</b></p> <div style="display: flex; justify-content: space-around;"> <div data-bbox="815 1709 1050 1856">  <p><b>MONODIREZIONALE // UNIDIRECTIONAL</b></p> </div> <div data-bbox="1050 1709 1286 1856">  <p><b>BIDIREZIONALE // BIDIRECTIONAL</b></p> </div> </div>
<p><b>SISTEMI OTTICI // OPTICAL SYSTEMS</b></p> <div style="display: flex; justify-content: space-around;"> <div data-bbox="427 1689 539 1796">  <p>• 7 •</p> </div> <div data-bbox="555 1689 667 1796">  <p>• 8 •</p> </div> </div>		

**illuminazione di arredo urbano contemporaneo //**  
*contemporary urban lighting*









**illuminazione di arredo  
urbano contemporaneo //**  
*contemporary urban lighting*

**PALI // poles**

254 **STEEL BLACK** POLE

258 **STEEL RED** POLE

262 **STEEL GREEN** POLE

**SISTEMI CIMA-PALO // pole-top systems**

266 **STEEL UP** POLE-TOP SYSTEM

**MENSOLE A PALO // pole arms**

268 **STEEL LINE** POLE ARM

270 **STEEL SOFT** POLE ARM

274 **STEEL FORK** POLE ARM

276 **STEEL AIR** POLE ARM

**MENSOLE A MURO // wall brackets**

278 **STEEL WALL** BRACKETS

---

# acciaio

## *steel*

La funzionalità a sostegno della luce. Spazi urbani dal respiro tradizionale o contemporaneo sono la giusta cornice per la collezione Steel.

*Functionality supports light. Urban spaces with a traditional or contemporary style are the ideal context for the Steel collection.*



## STEEL BLACK POLE

“Steel Black” è la serie di pali cilindrici in acciaio che offre funzionalità ed eleganza. Il perfetto raccordo del corpo illuminante nelle soluzioni testa-palo rende il sistema esteticamente interessante per percorsi ciclo-pedonali e aree verdi. Le soluzioni rastremate, caratterizzate dall'eleganza dei collari decorativi e del tappo in testa in alluminio, sono ideali per ogni contesto di illuminazione pubblica.

*“Steel Black” is a collection of steel cylindrical poles, functional and elegant at the same time. The design of the collection makes it well suited for cycle-pedestrian paths and green areas. The tapered version with the elegance of decorative collars and of the aluminum top cap are suitable for public lighting requirements.*

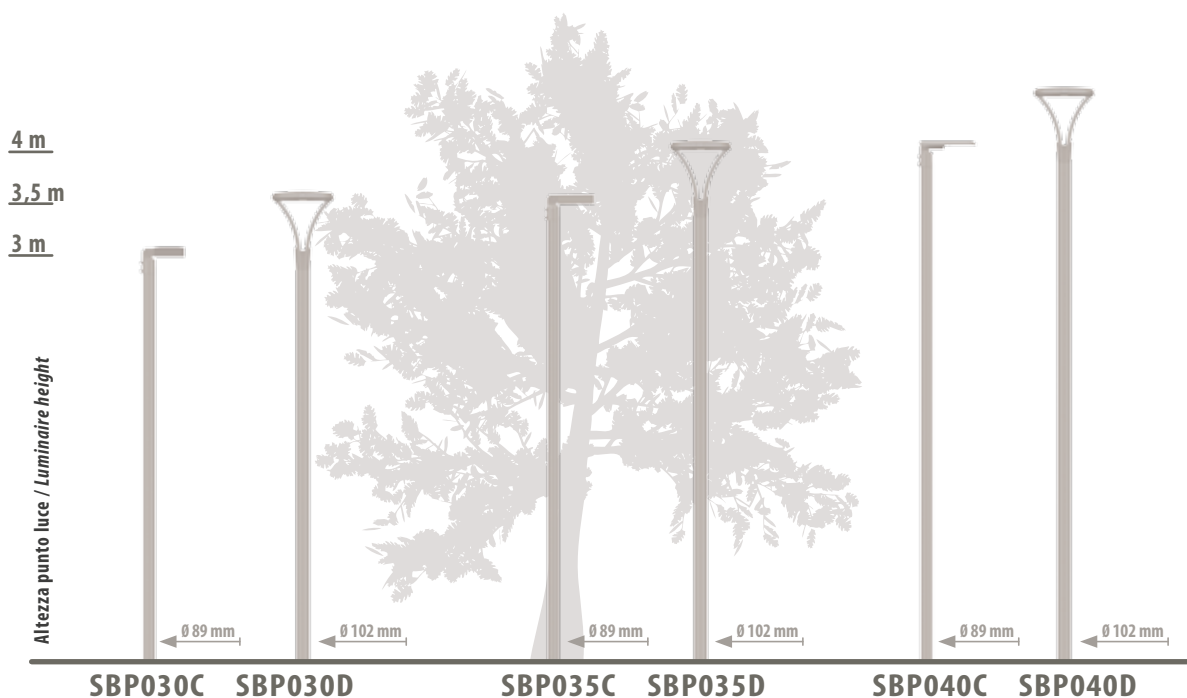

### Versioni Disponibili // Available Versions

Diametro 89 mm per tutti i corpi illuminanti con snodo regolabile / Diameter 89 mm for all lighting fixtures with adjustable arm

Diametro 102 mm per corpi illuminanti testa-palo o con sistema cima-palo Steel Up p. 266 /

Diameter 102 mm for pole-top fixtures or with Steel Up pole-top system p. 266

Tipo di fissaggio: flangia o fondazione / Fixing type: flange or foundation





**STEEL BLACK POLE**

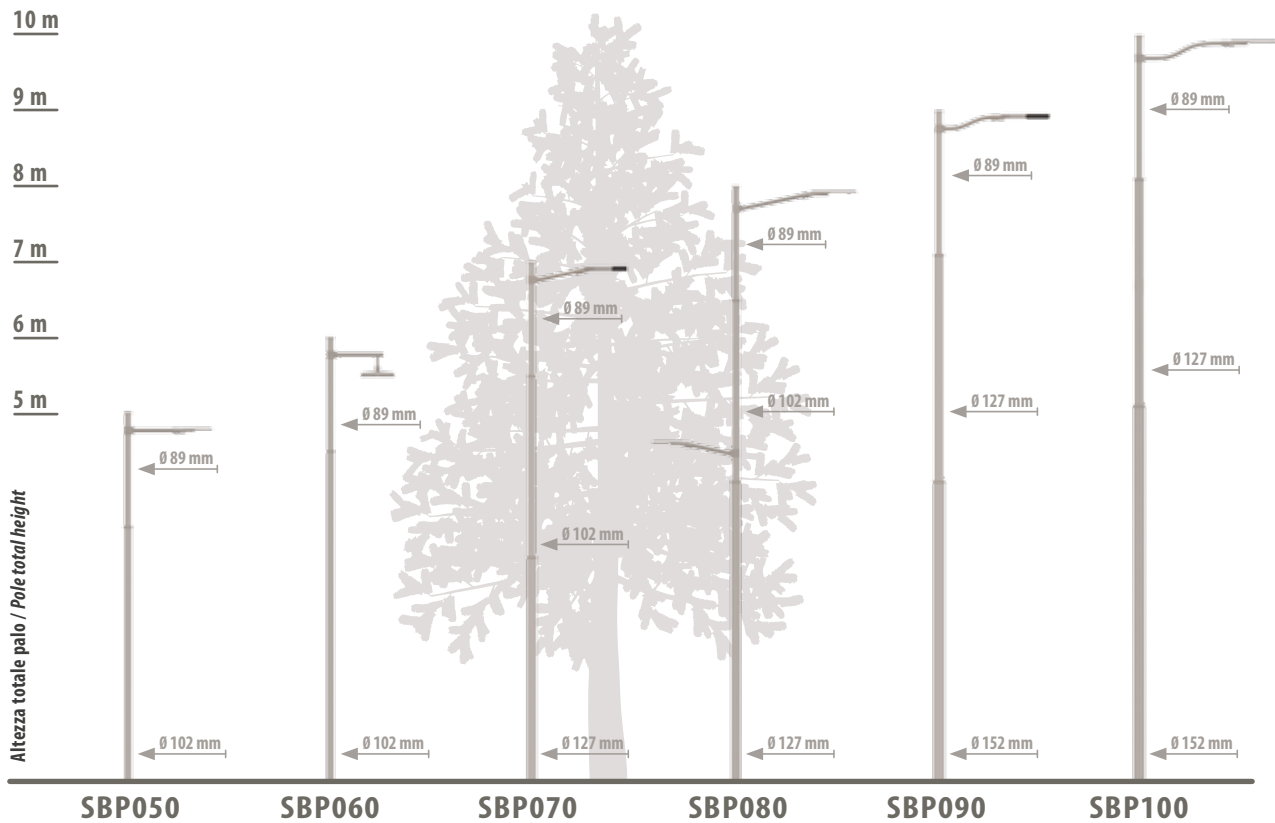

**Versioni Disponibili // Available Versions**

Su ogni palo è possibile montare le mensole Line - Soft - Fork - Air / The Line - Soft - Fork - Air arms can be mounted on each pole

SBP050 mensola singola o doppia / SBP050 single or double arm

SBP060 mensola singola, doppia o sfalsata / SBP060 single, double or split-level arm

SBP070 - SBP080 - SBP090 - SBP100 mensola singola, doppia, sfalsata, tripla o quadrupla / SBP070-SBP080-SBP090-SBP100 single, double, split-level, triple or quadruple arm

Tipo di fissaggio: flangia o fondazione / Fixing type: flange or foundation

**In dotazione // Supplied**

**Su richiesta // On request**



Collare copri-rastrematura / Flash collar



Tappo di testa / Top cap



Puntale LED / LED decorative tip

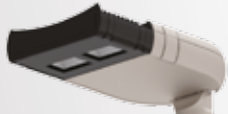

## STEEL RED POLE

“Steel Red” è una serie di pali conici in acciaio senza saldature a vista. Il sostegno pulito e slanciato consente un perfetto collocamento in ogni contesto urbano.

*“Steel Red” Pole is a collection of conical poles made of steel without visible welding. The clean and slender support ensures perfect installation in urban spaces.*

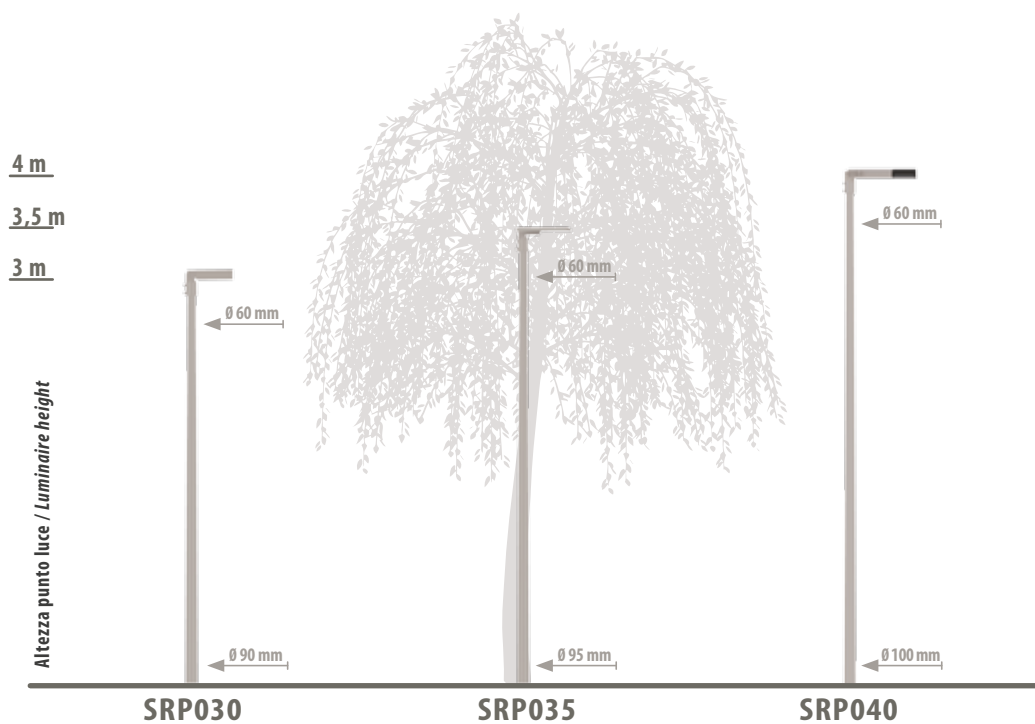

### Versioni Disponibili // Available Versions

Tipo di fissaggio: flangia o fondazione / Fixing type: flange or foundation





**STEEL RED POLE**

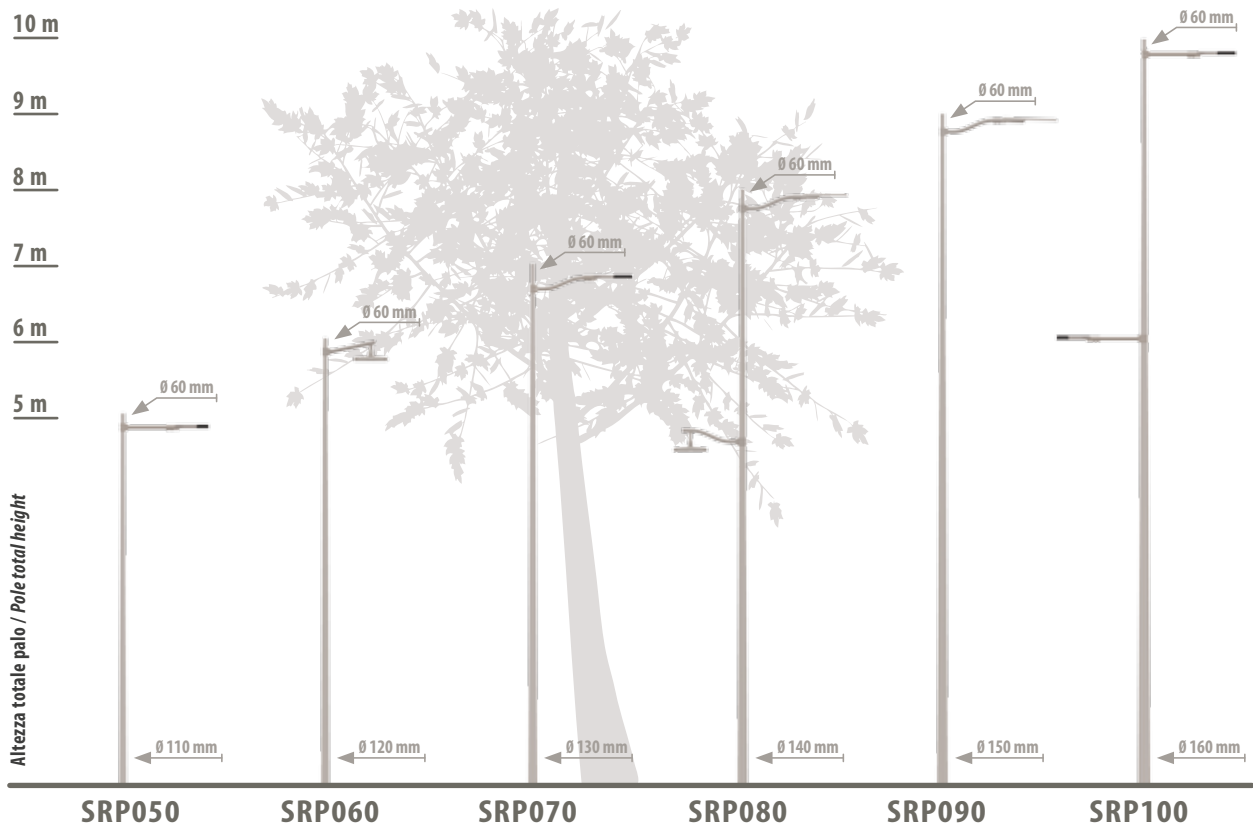

**Versioni Disponibili // Available Versions**

Su ogni palo è possibile montare le mensole Line - Soft - Fork - Air / The Line - Soft - Fork - Air arms can be mounted on each pole

SRP050 mensola singola o doppia / SRP050 single or double arm

SRP060 mensola singola, doppia o sfalsata / SRP060 single, double or split-level arm

SRP070 - SRP080 - SRP090 - SRP100 mensola singola, doppia, sfalsata, tripla o quadrupla /

SRP070 - SRP080 - SRP090 - SRP100 single, double, split-level, triple or quadruple arm

Tipo di fissaggio: flangia o fondazione / Fixing type: flange or foundation



## STEEL GREEN POLE

“Steel Green” è una serie di pali conici curvati in acciaio senza saldature a vista: una soluzione dinamica, ideale per contesti urbani ed extra-urbani.

*“Steel Red” Pole are a dynamic solution of steel curved conical poles without visible welding. Ideal for urban and extra-urban public lighting spaces.*

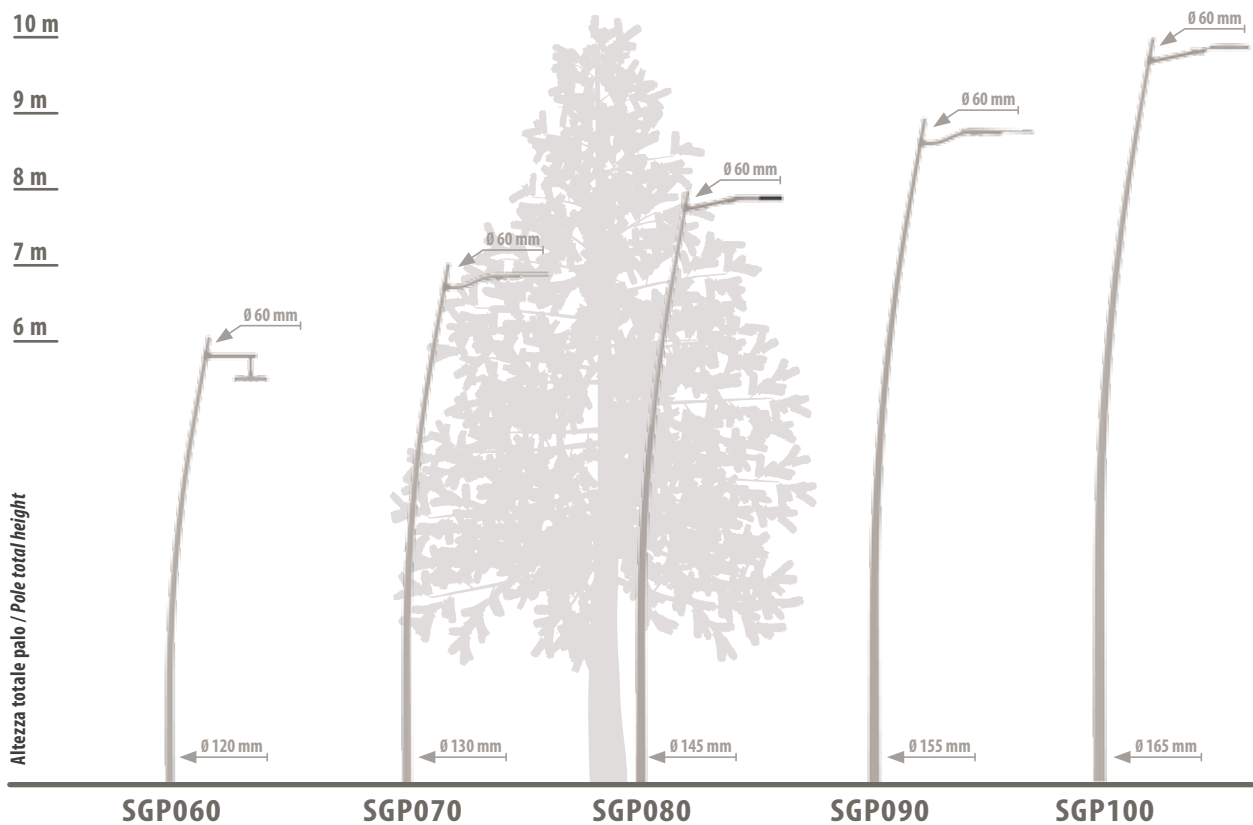

### Versioni Disponibili // Available Versions

Su ogni palo è possibile installare una mensola singola, modelli Line Inclined e Fork / A single arm, from either Line Inclined or Fork models, can be installed on each pole

Tipo di fissaggio: flangia o fondazione / Fixing type: flange or foundation

**illuminazione di arredo urbano contemporaneo //**  
*contemporary urban lighting*









## STEEL UP POLE-TOP SYSTEM

Il sistema cima-palo "Steel Up", pulito e lineare, è la soluzione ideale per installazioni testa-palo con corpi illuminanti a sospensione.

*"Steel Up" pole-top system, clean and linear, is the ideal suspended solution for top-mounted installations.*

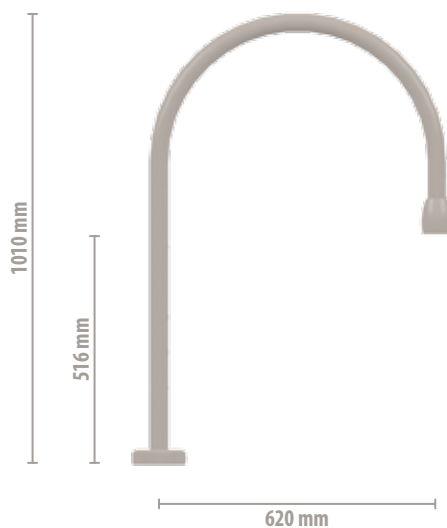

**SUM**

**STEEL UP**

### **Versioni Disponibili // Available Versions**

Sistema cima-palo installabile su pali SBP030 D - SBP035 D - SBP040 D /  
Pole-top system for installation on SBP030 D - SBP035 D - SBP040 D poles



## STEEL LINE POLE ARM

“Steel Line”, realizzate in acciaio, è la serie di mensole dal profilo essenziale e moderno, predisposte per l’installazione di corpi illuminanti con attacco laterale o a sospensione.

*“Steel Line” pole arms are a clean and essential steel solution. The series is designed for side and suspended installation of lighting fixtures.*

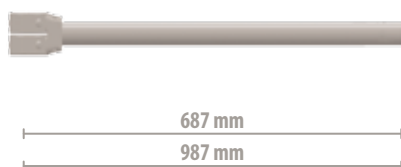

**SDM S B - SDM L B**

**STEEL LINE STRAIGHT B**

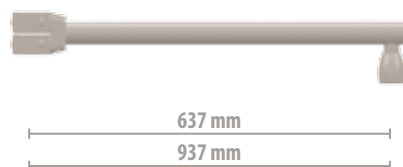

**SDM S A - SDM L A**

**STEEL LINE STRAIGHT A**

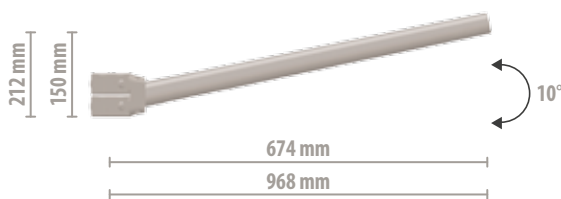

**SIM S B - SIM L B**

**STEEL LINE INCLINED B**

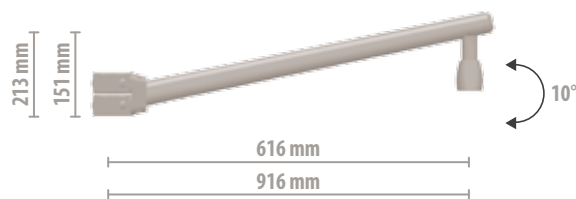

**SIM S A - SIM L A**

**STEEL LINE INCLINED A**

### Versioni Disponibili // Available Versions

Ogni mensola è disponibile in versione singola, doppia, tripla o quadrupla / Each arm is available in single, double, triple or quadruple version

SDM S B - SDM S A - SIM S B - SIM S A installabili su pali da 5 - 6 mt / SDM S B - SDM S A - SIM S B - SIM S A for installation on 5 - 6 mt poles

SDM L B - SDM L A - SIM L B - SIM L A installabili su pali da 7 - 8 - 9 - 10 mt / SDM L B - SDM L A - SIM L B - SIM L A for installation on 7 - 8 - 9 - 10 mt poles





## STEEL SOFT POLE ARM

Il profilo sinuoso contraddistingue "Steel Soft": una serie di mensole in acciaio curvato, dalla linea morbida e moderna.

*"Steel Soft" pole arm made of curved steel is characterised by a simple and sinuous style.*

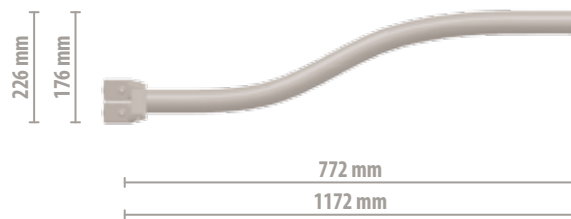

**SSM S B - SSM L B**

**STEEL SOFT B**

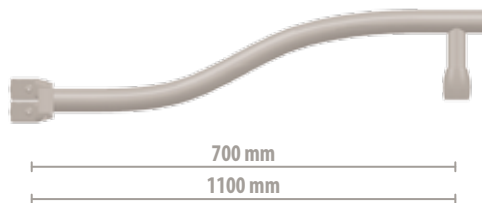

**SSM S A - SSM L A**

**STEEL SOFT A**

### Versioni Disponibili // Available Versions

La mensola è disponibile in versione singola, doppia, tripla o quadrupla / The arm is available in single, double, triple or quadruple version

SSM S B - SSM S A installabili su pali da 5 - 6 mt / SSM S B - SSM S A for installation on 5 - 6 mt poles

SSM L B - SSM L A installabili su pali da 7 - 8 - 9 - 10 mt / SSM L B - SSM L A for installation on 7 - 8 - 9 - 10 mt poles

**illuminazione di arredo urbano contemporaneo //**  
*contemporary urban lighting*







## STEEL FORK POLE ARM

Le mensole “Steel Fork”, realizzate in acciaio, si distinguono per la linea estrosa e affascinante.

*“Steel Fork” pole arm, made of steel, is characterised by a creative and fascinating line.*

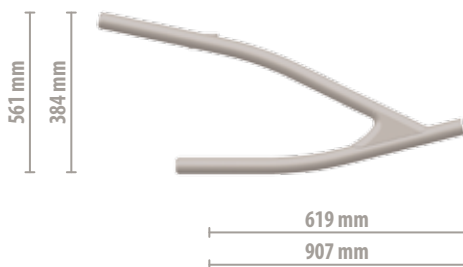

**SFM S B - SFM L B**

**STEEL FORK B**

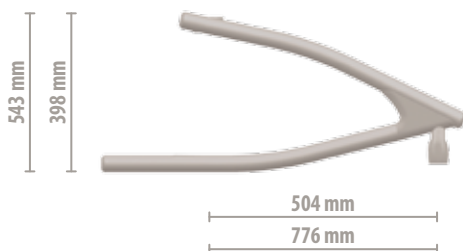

**SFM S A - SFM L A**

**STEEL FORK A**

### Versioni Disponibili // Available Versions

La mensola è disponibile in versione singola o doppia / The arm is available in single or double version

SFM S B - SFM S A installabili su pali da 5 - 6 mt / SFM S B - SFM S A for installation on 5 - 6 mt poles

SFM L B - SFM L A installabili su pali da 7 - 8 - 9 - 10 mt / SFM L B - SFM L A for installation on 7 - 8 - 9 - 10 mt poles





## STEEL AIR POLE ARM

La mensola "Steel Air", dal profilo curvato e sottile, rappresenta la soluzione a sospensione che meglio si adatta ad ogni esigenza di illuminazione urbana.

*"Steel Air" pole arm, regular and thin, is the best suspended solution for all urban lighting requirements.*

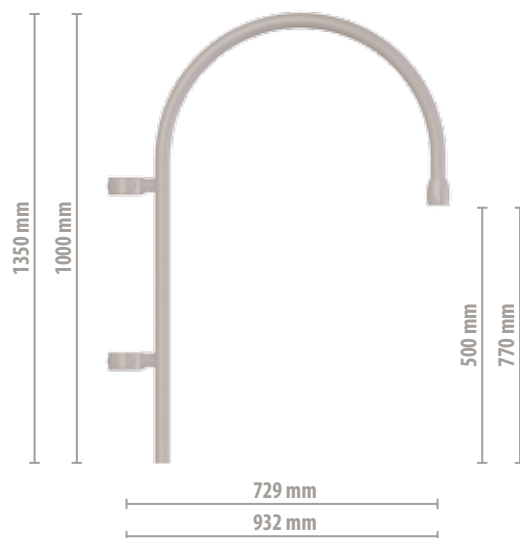

**SAS S - SAS L**

**STEEL AIR**

### Versioni Disponibili // Available Versions

Ogni mensola è disponibile in versione singola, doppia, tripla o quadrupla / Each arm is available in single, double, triple or quadruple version

SAS S installabile su pali da 5 - 6 mt / SAS S for installation on 5 - 6 mt poles

SAS L installabile su pali da 7 - 8 - 9 - 10 mt / SAS L for installation on 7 - 8 - 9 - 10 mt poles



**STEEL WALL BRACKETS**

Le mensole a muro "Steel" completano la collezione, riprendendone il design.

*The "Steel" Wall Brackets complete the wall-mounted series with a coordinated design.*



**SDW B**

**STEEL LINE STRAIGHT B**



**SDW A**

**STEEL LINE STRAIGHT A**

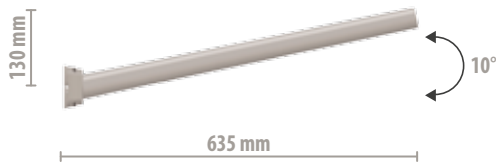

**SIW B**

**STEEL LINE INCLINED B**

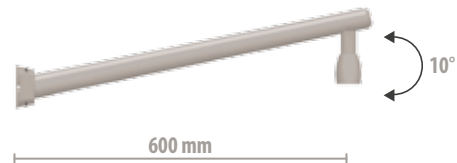

**SIW A**

**STEEL LINE INCLINED A**

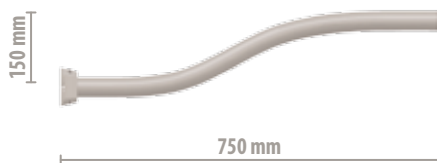

**SSW B**

**STEEL SOFT B**

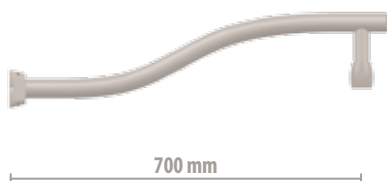

**SSW A**

**STEEL SOFT A**

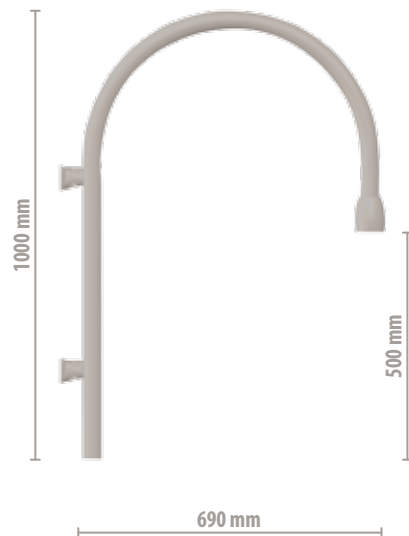

**SAW**

**STEEL AIR**

**illuminazione di arredo urbano contemporaneo //**  
*contemporary urban lighting*









**Illuminazione di arredo  
urbano contemporaneo //**  
*contemporary urban lighting*

**BOLLARD // bollards**

284 **PHAROS 090** BOLLARD

286 **PHAROS 140** BOLLARD

**TOTEM // totems**

292 **PHAROS** TOTEM

# Pharos

Pharos: piccoli fari di luce guidano i passanti  
nella notte.

*Pharos: small spotlights guiding people  
through the night.*





## PHAROS 090 BOLLARD

“Pharos 090” è una serie di bollard dalle linee eleganti e slanciate. Questi piccoli fari, a tre diverse altezze, rendono raffinato il contesto in cui si installano.

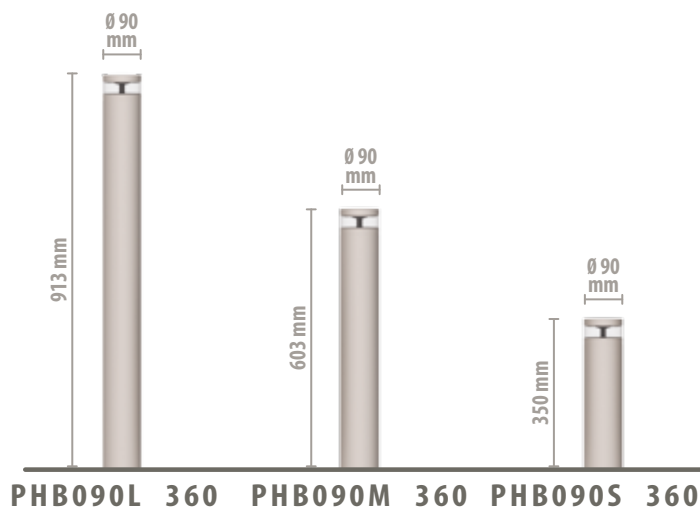
*“Pharos 090” has elegant and slender lines. These small spotlights, available in 3 different heights, give value to the surroundings where they are installed.*



### Specifiche Tecniche // Technical Features

<p><b>MATERIALE:</b></p> <p>trafila di alluminio, pressofusione di alluminio, vetro.</p>	<p><b>MATERIAL:</b></p> <p>extruded aluminium, die-cast aluminium, glass.</p>	<p> <b>COMPACT</b></p> <p>Apparecchio sigillato, fornito con connettore rapido per installazione immediata. <i>Sealed fixture with short power cable and IP electrical connector for a quick and simple linkage to the mains.</i></p>
<p><b>TEMPERATURA DI COLORE // COLOUR TEMPERATURE</b></p> <p>3000K // 4000K // 5700K</p>		<p><b>TIPO DI FISSAGGIO // FIXING TYPE</b></p> <div style="display: flex; justify-content: space-around;"> <div data-bbox="837 1501 1029 1653"> <p><b>FLANGIA // FLANGE</b></p> </div> <div data-bbox="1109 1501 1220 1653"> <p><b>PICCHETTO // EARTH SPIKE</b></p> </div> </div>
<p><b>DIMMERABILE // DIMMABLE</b></p>		
<p><b>SISTEMI OTTICI // OPTICAL SYSTEMS</b></p> <div style="text-align: center;">  <p>• 360° •</p> </div>		





## PHAROS 140 BOLLARD

“Pharos 140” è una serie di bollard dalle linee scultoree e forti. Questi piccoli fari, a tre diverse altezze, sono predisposti per un’illuminazione a 360° o 180°.

*“Pharos 140” has sculptural and strong lines. These small spotlights, available in three different heights, are designed for 360° or 180° lighting.*

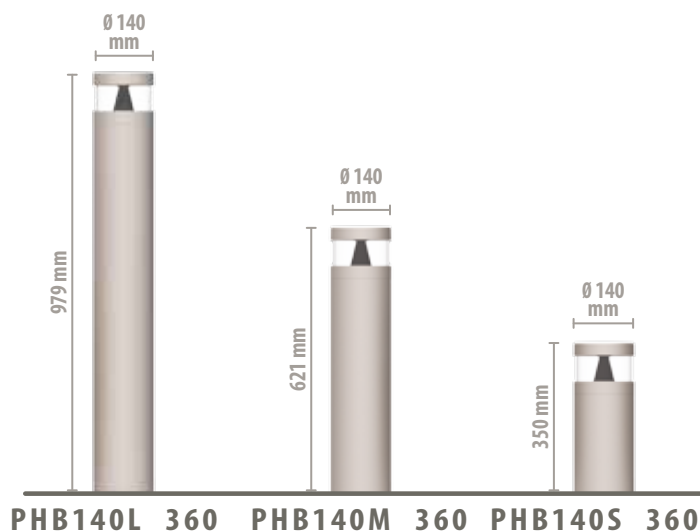

### Specifiche Tecniche // Technical Features



<p><b>MATERIALE:</b></p> <p>trafila di alluminio, pressofusione di alluminio, vetro.</p>	<p><b>MATERIAL:</b></p> <p>extruded aluminium, die-cast aluminium, glass.</p>	<p><b>COMPACT</b></p> <p>Apparecchio sigillato, fornito con connettore rapido per installazione immediata. <i>Sealed fixture with short power cable and IP electrical connector for a quick and simple linkage to the mains.</i></p>
<p><b>TEMPERATURA DI COLORE // COLOUR TEMPERATURE</b></p> <p>3000K // 4000K // 5700K</p>		<p><b>TIPO DI FISSAGGIO // FIXING TYPE</b></p> <div style="display: flex; justify-content: space-around;"> <div data-bbox="836 1493 1046 1655"> <p><b>FLANGIA // FLANGE</b></p> </div> <div data-bbox="1046 1493 1286 1655"> <p><b>PICCHETTO // EARTH SPIKE</b></p> </div> </div>
<p><b>DIMMERABILE // DIMMABLE</b></p>		
<p><b>SISTEMI OTTICI // OPTICAL SYSTEMS</b></p> <div style="text-align: center;"> <p>• 360° •</p> </div>		

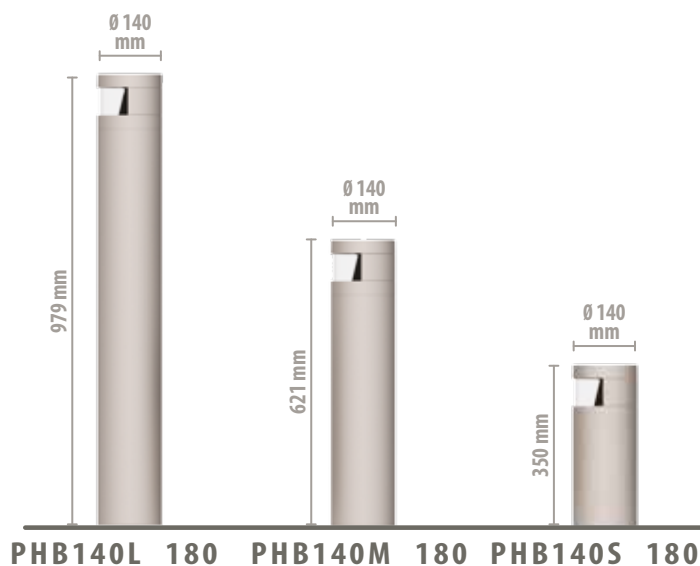

**PHAROS 140 BOLLARD**



**Specifiche Tecniche // Technical Features**

<p><b>MATERIALE:</b></p> <p>trafila di alluminio, pressofusione di alluminio, vetro.</p>	<p><b>MATERIAL:</b></p> <p>extruded aluminium, die-cast aluminium, glass.</p>	<p> <b>COMPACT</b></p> <p>Apparecchio sigillato, fornito con connettore rapido per installazione immediata. <i>Sealed fixture with short power cable and IP electrical connector for a quick and simple linkage to the mains.</i></p>
<p><b>TEMPERATURA DI COLORE // COLOUR TEMPERATURE</b></p> <p>3000K // 4000K // 5700K</p>		<p><b>TIPO DI FISSAGGIO // FIXING TYPE</b></p> <div style="display: flex; justify-content: space-around;"> <div data-bbox="837 1501 1029 1653"> <p><b>FLANGIA // FLANGE</b></p> </div> <div data-bbox="1053 1501 1244 1653"> <p><b>PICCHETTO // EARTH SPIKE</b></p> </div> </div>
<p><b>DIMMERABILE // DIMMABLE</b></p>		
<p><b>SISTEMI OTTICI // OPTICAL SYSTEMS</b></p>		
<div style="text-align: center;">  <p>• 6 180 •</p> </div>		

**illuminazione di arredo urbano contemporaneo //**  
*contemporary urban lighting*









## PHAROS TOTEM

I totem "Pharos" sono una soluzione contemporanea per illuminare i centri cittadini e le aree pedonali.

*"Pharos" totems are an ideal contemporary solution to illuminate city centres and pedestrian areas.*

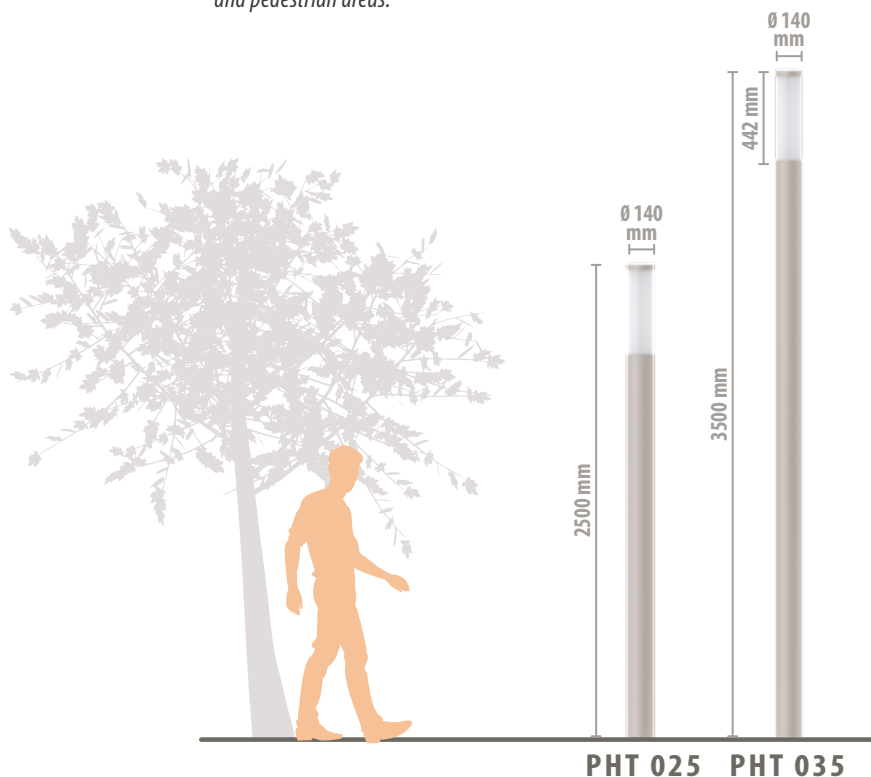

### Specifiche Tecniche // Technical Features

<p><b>MATERIALE:</b> trafa di alluminio, pressofusione di alluminio, policarbonato.</p>	<p><b>MATERIAL:</b> extruded aluminium, die-cast aluminium, polycarbonate.</p>	<p><b>COMPACT</b> Apparecchio sigillato, fornito con connettore rapido per installazione immediata. <i>Sealed fixture with short power cable and IP electrical connector for a quick and simple linkage to the mains.</i></p>
<p><b>TEMPERATURA DI COLORE // COLOUR TEMPERATURE</b> 3000K // 4000K // 5700K</p>		<p><b>TIPO DI FISSAGGIO // FIXING TYPE</b></p>
<p><b>DIMMERABILE // DIMMABLE</b></p>		
<p><b>SISTEMI OTTICI // OPTICAL SYSTEMS</b></p>		
<p> • 6360° •</p>		<p><b>FLANGIA // FLANGE</b>      <b>PICCHETTO // EARTH SPIKE</b></p>

**illuminazione di arredo urbano contemporaneo //**  
*contemporary urban lighting*











**Illuminazione di arredo  
di design //**  
*design urban lighting*

**CORPI ILLUMINANTI //** *lighting fixtures*

298

**KROM**

**PALI //** *poles*

300

**KROM POLE**

**BOLLARD //** *bollards*

304

**KROM BOLLARD**

---

# K r o m

Design: Ing. Arch. Paolo Ceredi, Arch. Francesco Ceredi

Krom è una collezione dalle linee affilate e rigorose che dialoga in totale armonia con la nitidezza formale degli spazi contemporanei.

*The sharp and rigorous lines of the Krom collection create a harmonic dialogue with the clean shapes of contemporary spaces.*



**KROM**

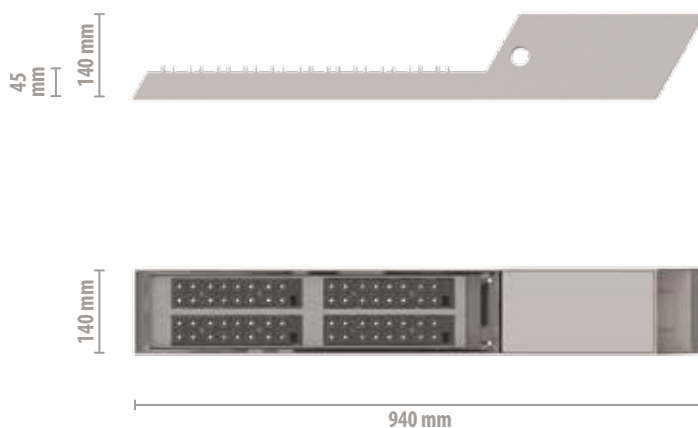

**KRO  
GLASSED**

**Specifiche Tecniche // Technical Features**

<b>MATERIALE:</b>	<b>MATERIAL:</b>
lamiera di acciaio, vetro.	steel sheet, glass.

<b>TEMPERATURA DI COLORE // COLOUR TEMPERATURE</b>
3000K // 4000K // 5700K

<b>DIMMERABILE // DIMMABLE</b>
--------------------------------

<b>SISTEMI OTTICI // OPTICAL SYSTEMS</b>
--



• TYPE 2 • • TYPE 3 •

	<b>OPENABLE</b>
---	-----------------

Apparecchio apribile e rigenerabile (componentistica interna sostituibile) con l'utilizzo di utensili.  
*Openable fixture with basic tools - Replaceable internal components using basic tools.*

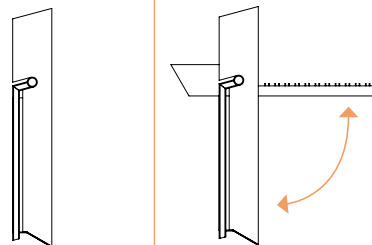

**GIORNO // DAY**

**NOTTE // NIGHT**

**SU RICHIESTA // ON REQUEST**  
 Soluzione motorizzata di chiusura del corpo illuminante all'interno del profilo del palo  
*// Motorized solution to close the lighting fixture inside the pole section*

Il corpo illuminante Krom può essere installato solo sul palo della collezione //  
*Krom fixture can only be installed on the pole of the collection*

Per maggiori informazioni vedi scheda tecnica prodotto // *For more information see our product datasheet*





## KROM POLE

Dal profilo tagliente, le forme del "Krom" trovano ispirazione nella storia del design. Un oggetto dinamico, in acciaio e alluminio, dotato di una mobilità versatile, capace di animare la staticità dello spazio urbano.

*"Krom" shapes with a sharp outline are inspired by the history of design. This dynamic, steel and aluminium pole is characterized by a versatile mobility and is able to enliven static urban spaces.*

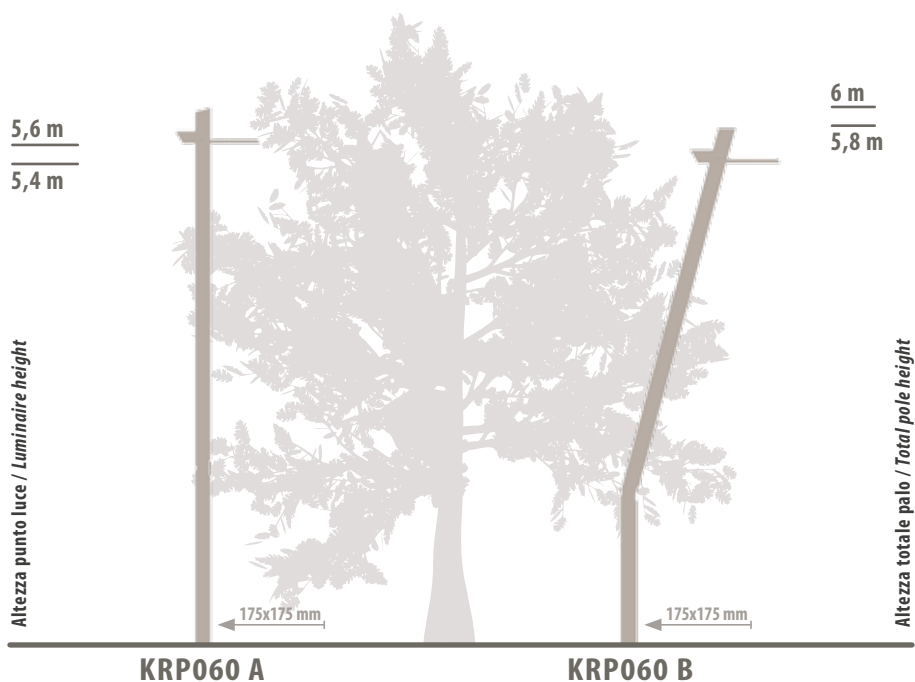

**KRP060 A**

**KRP060 B**

### Versioni Disponibili // Available Versions

Disponibile solo per corpo illuminante Krom / Only available for luminaire Krom

Tipo di fissaggio: flangia o fondazione / Fixing type: flange or foundation

### Sbraccio // Extension



**illuminazione di arredo urbano di design //**  
*design urban lighting*











## KROM BOLLARD

Scheggia poliedrica dal taglio prezioso che sfaccetta la luce come una gemma.

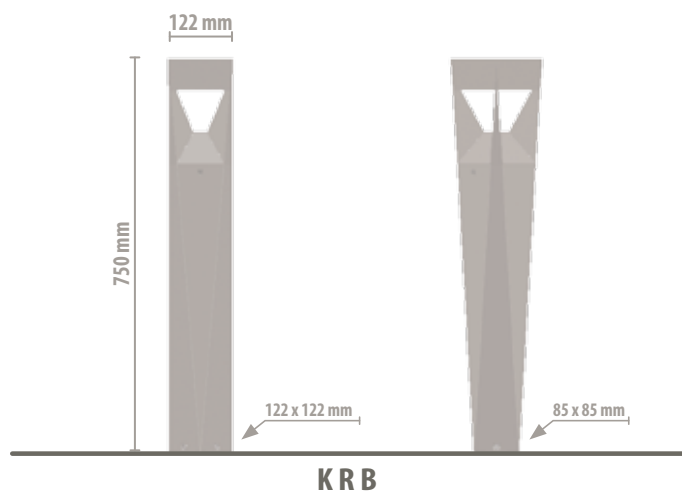
*Polyhedric sliver with a precious cut that facets the light as a gem.*

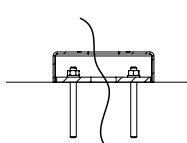
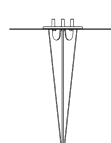

### Specifiche Tecniche // Technical Features

<b>MATERIALE:</b>	<b>MATERIAL:</b>	<b>COMPACT</b>
lamiera di acciaio, pressofusione di alluminio, PMMA.	steel sheet, die-cast aluminium, PMMA.	Apparecchio sigillato, fornito con connettore rapido per installazione immediata. <i>Sealed fixture with short power cable and IP electrical connector for a quick and simple linkage to the mains.</i>
<b>TEMPERATURA DI COLORE // COLOUR TEMPERATURE</b>		<b>TIPO DI FISSAGGIO // FIXING TYPE</b>
3000K // 4000K // 5700K		<div style="display: flex; justify-content: space-around;"> <div style="text-align: center;">  <p><b>FLANGIA // FLANGE</b></p> </div> <div style="text-align: center;">  <p><b>PICCHETTO // EARTH SPIKE</b></p> </div> </div>
<b>DIMMERABILE // DIMMABLE</b>		
<b>SISTEMI OTTICI // OPTICAL SYSTEMS</b>		
 <p>• 6360° •</p>		



**illuminazione di arredo urbano di design //**  
*design urban lighting*







**Illuminazione di arredo  
di design //**  
*design urban lighting*

**CORPI ILLUMINANTI //** *lighting fixtures*

310 **AQUILONE A**

312 **AQUILONE B**

**PALI //** *poles*

316 **AQUILONE FOIL POLE**

320 **AQUILONE KITE POLE**

324 **AQUILONE DELTA POLE**

---

# Aquilone

Aquilone è nato con il vento. L'aria e la luce giocano con la sua forma, a volte sfuggente ed inafferrabile, altre volte centrata come di stallo.

*Aquilone was born from the wind. Air and light play with its shape, sometimes intangible and fleeting, other times steady and fixed.*







## AQUILONE A

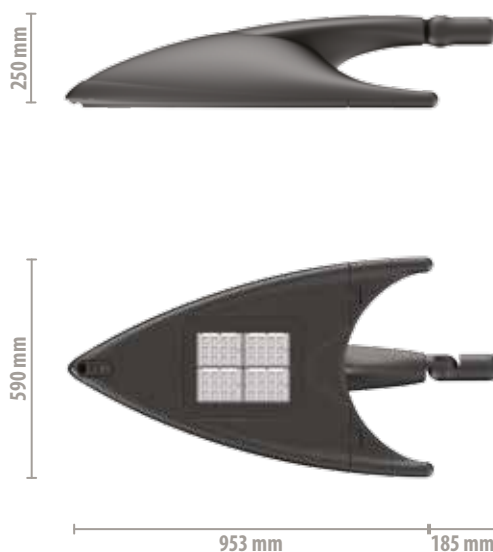

## AQA A GLASS-FREE

### Specifiche Tecniche // Technical Features

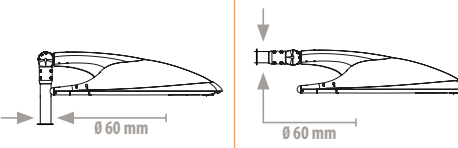
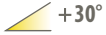
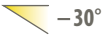
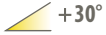
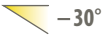
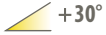
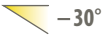
<b>MATERIALE:</b> pressofusione di alluminio.	<b>MATERIAL:</b> die-cast aluminium.	 <b>TIMELESS</b> Apparecchio apribile e rigenerabile (componentistica interna sostituibile) senza utilizzo di utensili. <i>Tool-free openable fixture - Replaceable internal components without the need of tools.</i>		
<b>TEMPERATURA DI COLORE // COLOUR TEMPERATURE</b> 2200K // 3000K // 4000K // 5700K		<b>TIPO DI FISSAGGIO // FIXING TYPE</b>		
<b>DIMMERABILE // DIMMABLE</b>				
<b>SISTEMI OTTICI // OPTICAL SYSTEMS</b>		<table border="1"> <tr> <td data-bbox="817 1675 1050 1810"> <b>TESTA-PALO // POLE-TOP</b>                      Regolabile con step da 2,5°  <i>Adjustable with 2,5° steps</i>                       +30°                 </td> <td data-bbox="1050 1675 1286 1810"> <b>LATERALE // SIDE</b>                      Regolabile con step da 2,5°  <i>Adjustable with 2,5° steps</i>                       -30°                 </td> </tr> </table>	<b>TESTA-PALO // POLE-TOP</b> Regolabile con step da 2,5° <i>Adjustable with 2,5° steps</i>  +30°	<b>LATERALE // SIDE</b> Regolabile con step da 2,5° <i>Adjustable with 2,5° steps</i>  -30°
<b>TESTA-PALO // POLE-TOP</b> Regolabile con step da 2,5° <i>Adjustable with 2,5° steps</i>  +30°	<b>LATERALE // SIDE</b> Regolabile con step da 2,5° <i>Adjustable with 2,5° steps</i>  -30°			

Disponibile anche nella versione a scarica da 100 a 400 W // Also available in 100 to 400W discharge lamp

Per maggiori informazioni vedi scheda tecnica prodotto // For more information see our product datasheet



**AQUILONE B**

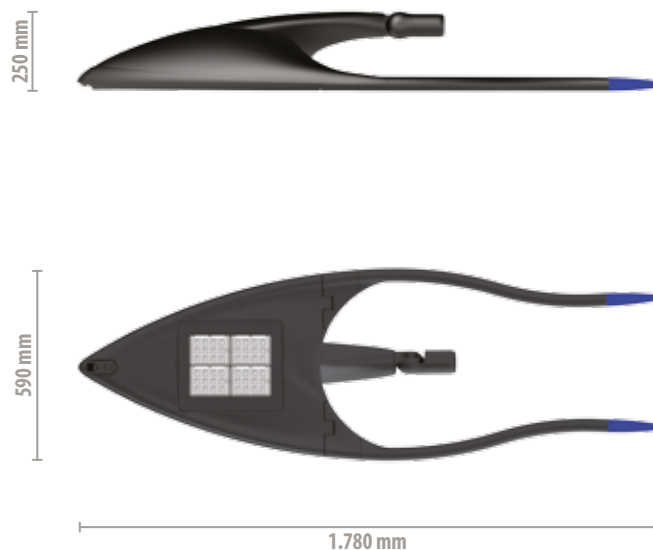

**AQA B  
GLASS-FREE**

**Specifiche Tecniche // Technical Features**

<b>MATERIALE:</b>	<b>MATERIAL:</b>	<b>TIMELESS</b>
pressofusione di alluminio.	die-cast aluminium.	Apparecchio apribile e rigenerabile (componentistica interna sostituibile) senza utilizzo di utensili. <i>Tool-free openable fixture - Replaceable internal components without the need of tools.</i>
<b>TEMPERATURA DI COLORE // COLOUR TEMPERATURE</b>		<b>TIPO DI FISSAGGIO // FIXING TYPE</b>
2200K // 3000K // 4000K // 5700K		
<b>DIMMERABILE // DIMMABLE</b>		<b>TESTA-PALO // POLE-TOP</b>
<b>SISTEMI OTTICI // OPTICAL SYSTEMS</b>		<b>LATERALE // SIDE</b>
		Regolabile con step da 2,5° <i>Adjustable with 2,5° steps</i> 
Regolabile con step da 2,5° <i>Adjustable with 2,5° steps</i> 		

**COLORE TERMINALI LED blu, rosso, verde, bianco**  
**TIP COLOUR LED blue, red, green, white**

**Disponibile anche nella versione a scarica da 100 a 400 W // Also available in 100 to 400W discharge lamp**

Per maggiori informazioni vedi scheda tecnica prodotto // For more information see our product datasheet

**illuminazione di arredo urbano di design //**  
*design architectural lighting*



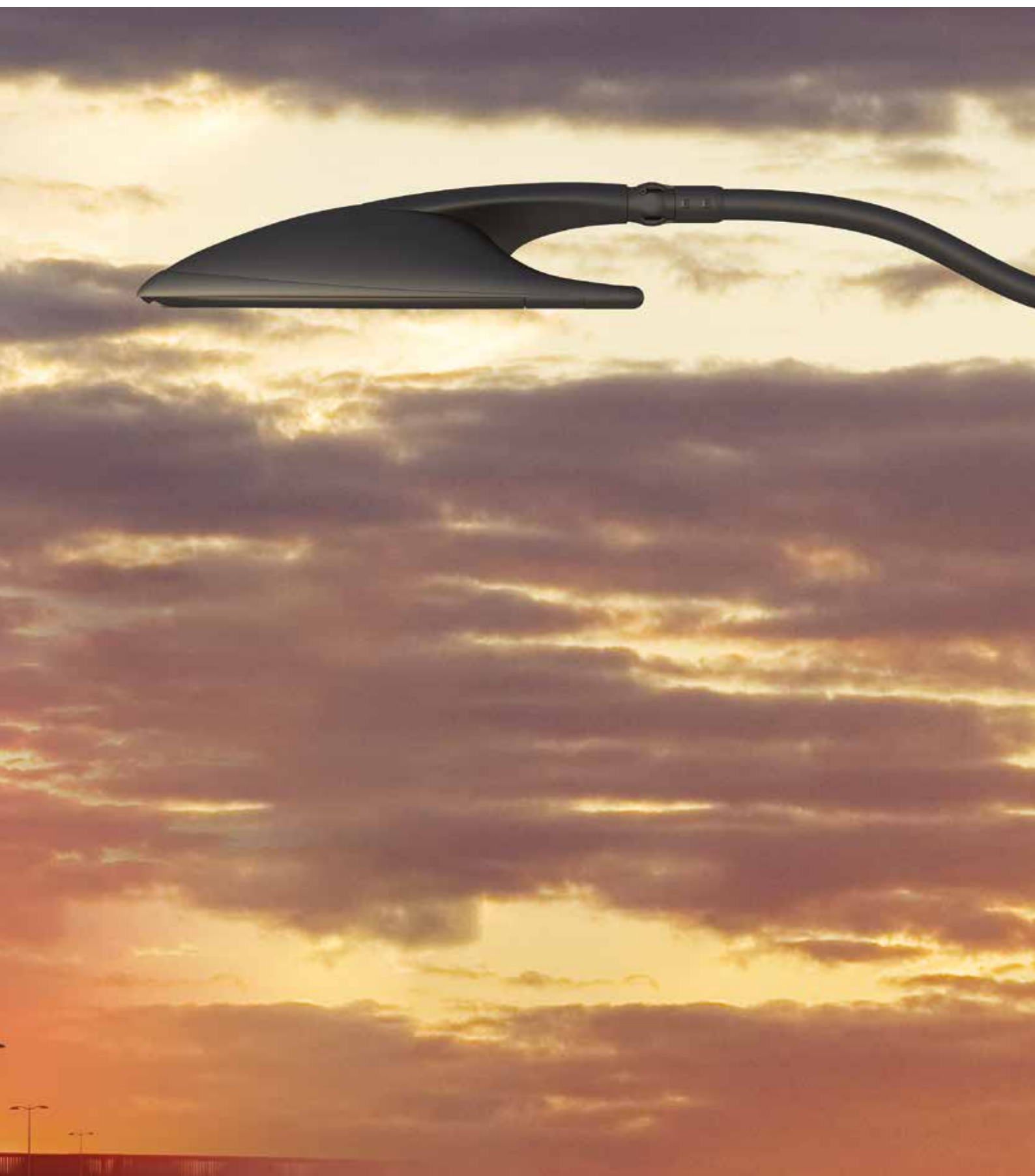





## AQUILONE FOIL POLE

“Aquilone Foil”, sfruttando appieno la tecnologia di laminatura del tubo di acciaio, si distingue per il fusto ondulato e la leggera inclinazione. La serie è ulteriormente impreziosita dai terminali a LED del corpo illuminante (disponibili nei colori verde, blu, rosso o bianco).

*“Aquilone Foil” takes full advantage of the innovative lamination technology involved in the manufacturing of the steel pole. The curved and slightly tilted design is enhanced by the backlit tails (available in green, blue, red and white).*

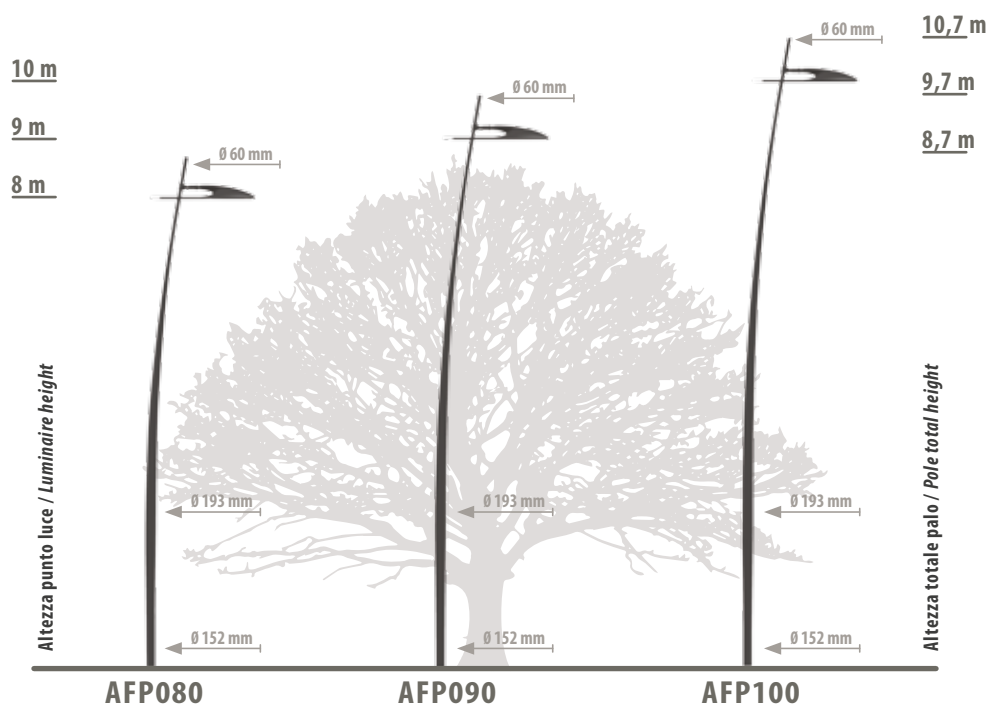

### Versioni Disponibili // Available Versions

Disponibile solo per corpo illuminante Aquilone-B / Only available for Aquilone-B lighting fixture

Tipo di fissaggio: flangia o fondazione / Fixing type: flange or foundation

**illuminazione di arredo urbano di design //**  
*design architectural lighting*



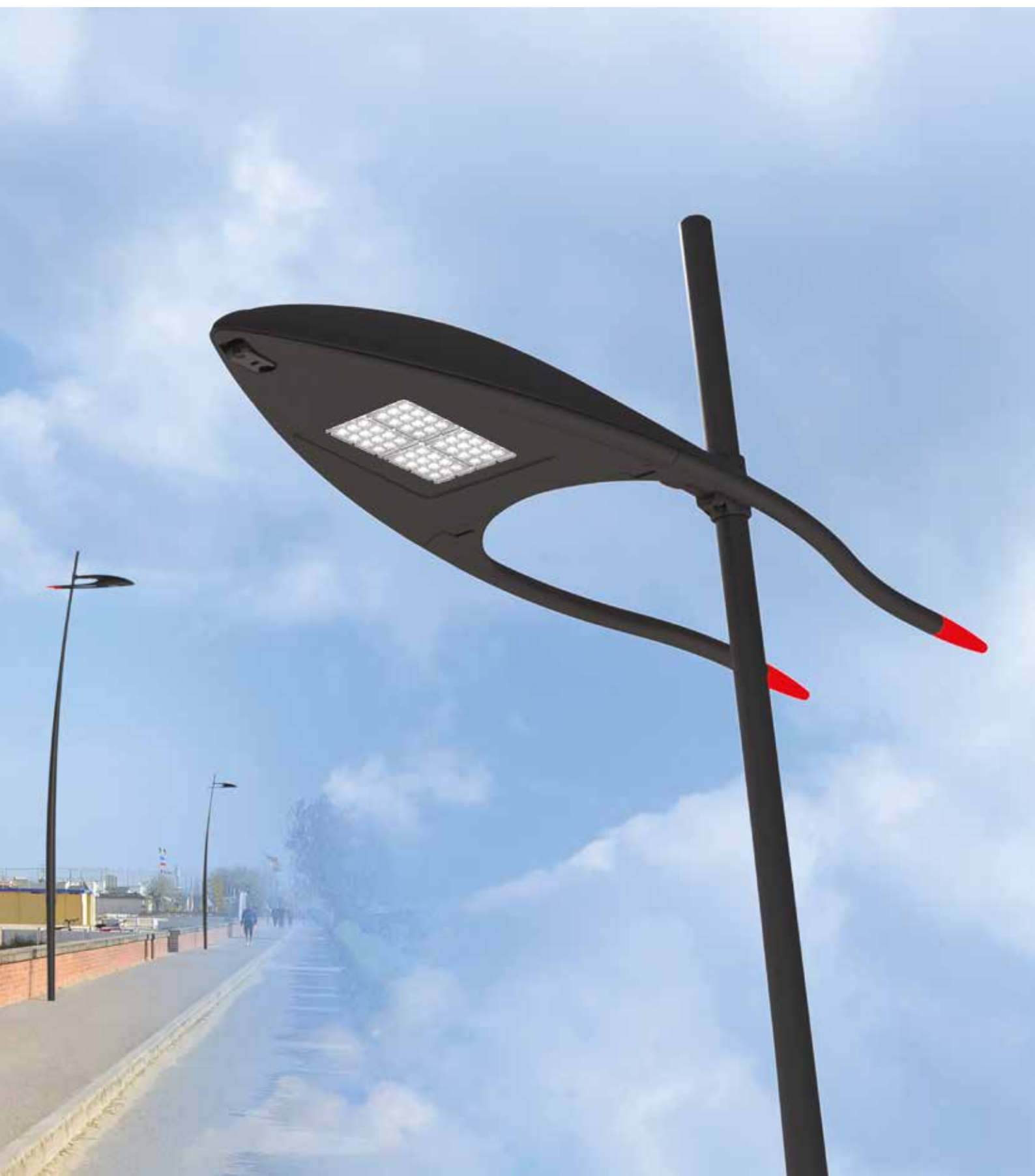





## AQUILONE KITE POLE

“Aquilone Kite”, realizzato in acciaio laminato a caldo, è caratterizzato dall'integrazione formale tra la linearità del fusto conico del palo e l'ampia curvatura dei terminali del corpo illuminante. Il profilo eccentrico ed originale che ne consegue lo rende un elemento distintivo del panorama urbano.

*“Aquilone Kite” is made of hot rolled steel. The balance between the line of the pole and the curve of the lighting fixture produces a quirky and unique final design, which is sure to set it apart in the urban landscape.*

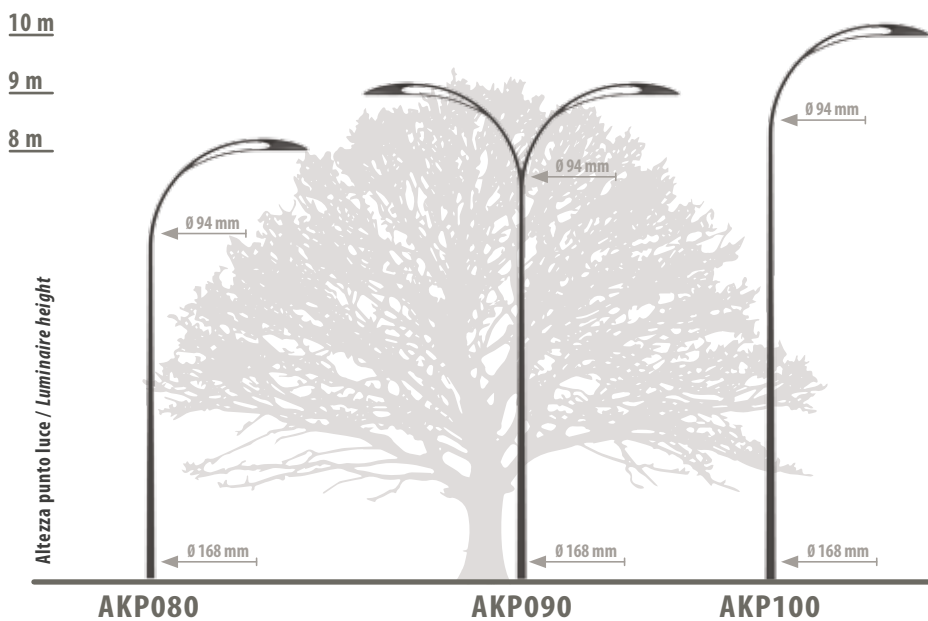

### Versioni Disponibili // Available Versions

AKP080 - AKP090 - AKP100 mensola singola o doppia / AKP080 - AKP090 - AKP100 single or double arm

Disponibile solo per corpo illuminante Aquilone-A / Only available for Aquilone-A lighting fixture

Tipo di fissaggio: flangia o fondazione / Fixing type: flange or foundation

### Sbraccio // Extension

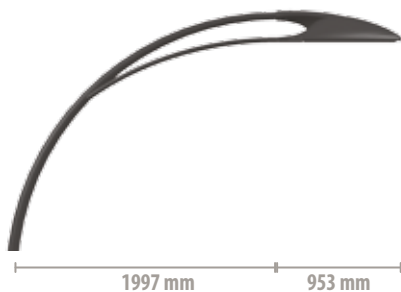

**illuminazione di arredo urbano di design //**  
*design urban lighting*







## AQUILONE DELTA POLE

“Aquilone Delta”, realizzato in acciaio laminato a caldo, è un sistema di illuminazione raffinato, dal profilo sottile e slanciato. Il palo conico si assottiglia nella parte centrale, enfatizzando la sua corsa verso l’alto, dove il corpo illuminante sembra sospeso.

*“Aquilone Delta” is a refined lighting system. Designed to appear refined and slender, it is made in hot rolled steel. Its conical light pole gets thinner in the central part and thus emphasizes its stretching upwards, making the light fixtures appear suspended.*

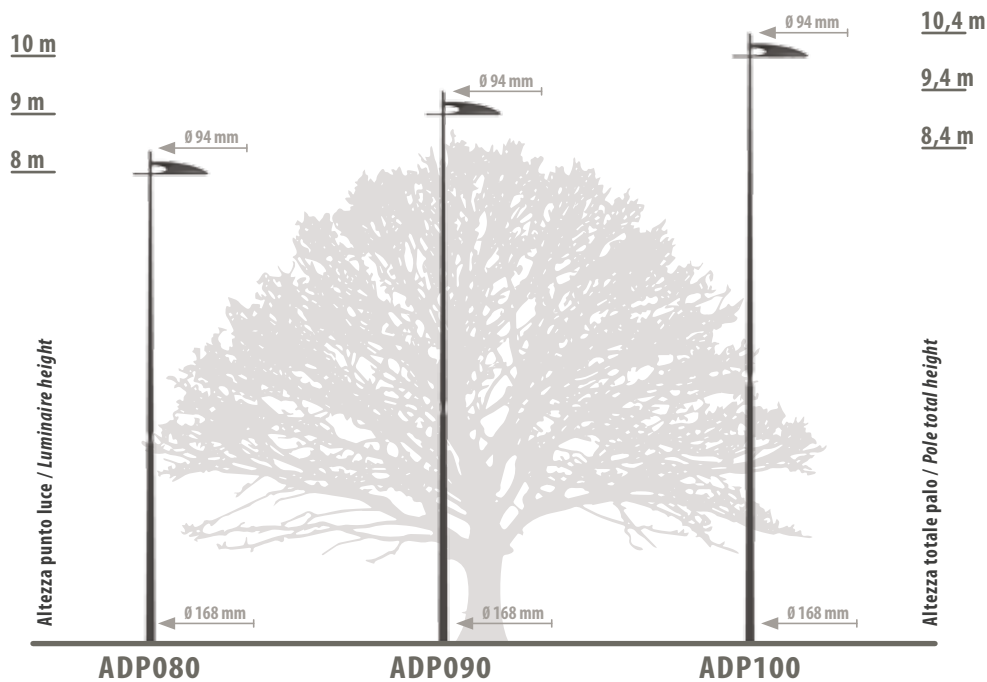

### Versioni Disponibili // Available Versions

Disponibile solo per corpo illuminante Aquilone-A / Only available for Aquilone-A lighting fixture

Tipo di fissaggio: flangia o fondazione / Fixing type: flange or foundation



**illuminazione di arredo urbano di design //**  
*design urban lighting*







**Illuminazione di arredo  
di design //**  
*design urban lighting*

**CORPI ILLUMINANTI //** *lighting fixtures*

330 **CAMELOT A**

332 **CAMELOT C**

**PALI //** *poles*

334 **CAMELOT ELAINE POLE**

338 **CAMELOT LOT POLE**

**MENSOLE A MURO //** *wall brackets*

340 **CAMELOT WALL BRACKET**

---

# Camelot

Camelot, la leggendaria fortezza dalle fatidiche mura merlate... un sistema di illuminazione suggestivo e versatile, con un'estetica dal gusto contemporaneo che evoca inevitabilmente le favole.

*The legendary castle of Camelot, with its crenelated walls... a charming and versatile lighting system, whose contemporary looks will inevitably bring you back to an era of fairy tales.*







## CAMELOT A



## CAM A GLASS-FREE

### Specifiche Tecniche // Technical Features

<b>MATERIALE:</b>	<b>MATERIAL:</b>	<b>TIMELESS</b>
pressofusione di alluminio, lastra di alluminio.	die-cast aluminium, aluminium sheet.	Apparecchio apribile e rigenerabile (componentistica interna sostituibile) senza utilizzo di utensili. <i>Tool-free openable fixture - Replaceable internal components without the need of tools.</i>
<b>TEMPERATURA DI COLORE // COLOUR TEMPERATURE</b>		<b>TIPO DI FISSAGGIO // FIXING TYPE</b>
2200K // 3000K // 4000K // 5700K		
<b>DIMMERABILE // DIMMABLE</b>		
<b>SISTEMI OTTICI // OPTICAL SYSTEMS</b>		
		<b>SOSPENSIONE // SUSPENDED</b>
• TYPE 1 •	• TYPE 2 •	
• TYPE 3 •	• TYPE 5 •	

Disponibile anche nella versione a scarica da 50 a 150 W // Also available in 50 to 150W discharge lamp

Per maggiori informazioni vedi scheda tecnica prodotto // For more information see our product datasheet



**CAMELOT C**



**CAM C  
GLASS-FREE**

**Specifiche Tecniche // Technical Features**

<b>MATERIALE:</b>	<b>MATERIAL:</b>	<b>TIMELESS</b>
pressofusione di alluminio, lastra di alluminio.	die-cast aluminium, aluminium sheet.	Apparecchio apribile e rigenerabile (componentistica interna sostituibile) senza utilizzo di utensili. <i>Tool-free openable fixture - Replaceable internal components without the need of tools.</i>
<b>TEMPERATURA DI COLORE // COLOUR TEMPERATURE</b>		<b>TIPO DI FISSAGGIO // FIXING TYPE</b>
2200K // 3000K // 4000K // 5700K		
<b>DIMMERABILE // DIMMABLE</b>		
<b>SISTEMI OTTICI // OPTICAL SYSTEMS</b>		<b>TESTA-PALO // POLE-TOP</b>
<p>• TYPE 2 •    • TYPE 3 •    • TYPE 5 •</p>		

Disponibile anche nella versione a scarica da 50 a 150 W // Also available in 50 to 150W discharge lamp

Per maggiori informazioni vedi scheda tecnica prodotto // For more information see our product datasheet



## CAMELOT ELAINE POLE

“Camelot Elaine” è un sistema di illuminazione in acciaio, costituito da un fusto rastremato con anello decorativo di raccordo e da un innesto superiore per il corpo illuminante testa-palo. Si distingue per la fantasia cromatica del cappello (grigio, rosso, giallo, blu o verde) ed è la soluzione ideale per aree pedonali, parchi, giardini e zone residenziali.

*“Camelot Elaine” is a steel lighting system made of an undulated trunk with a decorative connecting ring and an upper fixture for the pole-top lighting fixture. The pole is characterised by caps of different colours (grey, red, yellow, blue or green) and is ideal for pedestrian areas, parks, gardens and residential areas.*

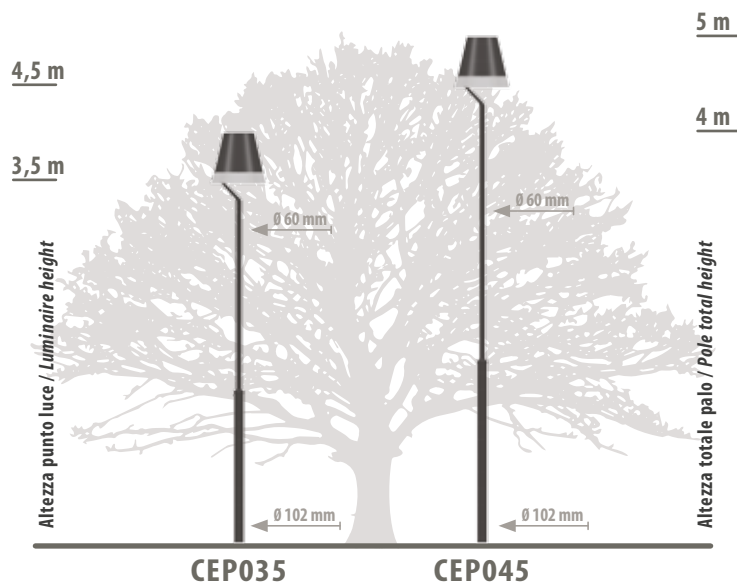

### Versioni Disponibili // Available Versions

Disponibile solo per corpo illuminante Camelot-C / Only available for Camelot-C lighting fixture  
 Tipo di fissaggio: flangia o fondazione / Fixing type: flange or foundation



**illuminazione di arredo urbano di design //**  
*design urban lighting*









## CAMELOT LOT POLE

“Camelot Lot” si distingue per l’offerta cromatica del cappello e dei terminali a LED (disponibili in grigio, rosso, giallo, blu o verde). Il palo, cilindrico rastremato, per la varietà delle soluzioni compositive, è in grado di caratterizzare una molteplicità di contesti: zone residenziali ed aree extraurbane, percorsi pedonali e parchi, strade e piazze di medie dimensioni.

“Camelot Lot” is characterised by a wide range of colour combinations for the lighting fixture and the decorative LED tips (available in grey, red, yellow, blue or green). The tapered cylindrical pole, with modular design solutions, is featured in many different contexts: residential and suburban areas, pedestrian walkways and parks, streets and medium-sized squares.

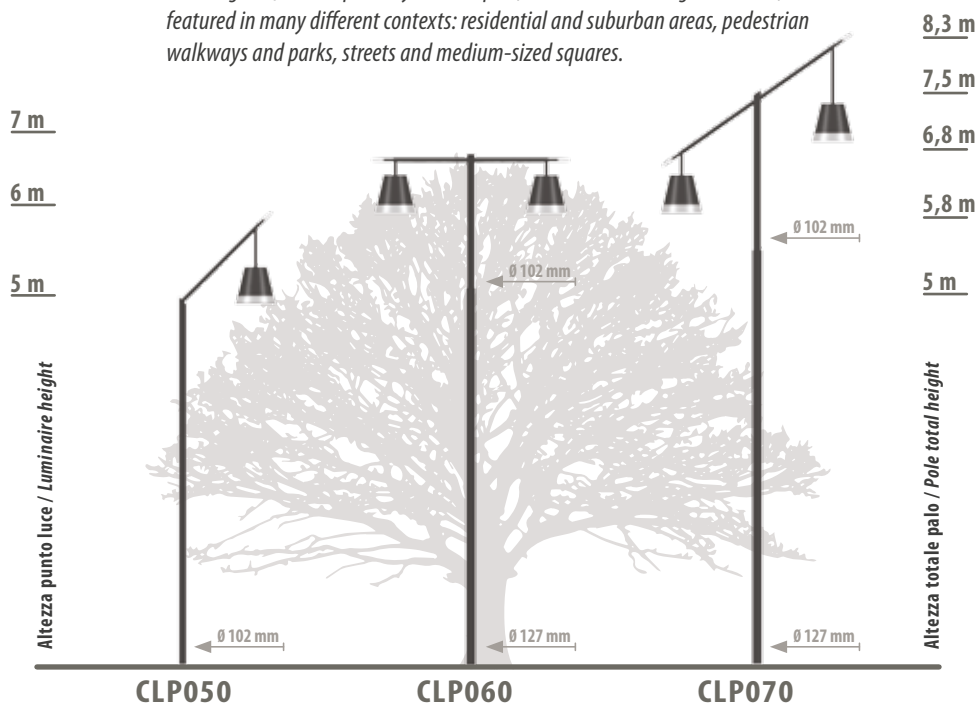

### Versioni Disponibili // Available Versions

Disponibile solo per corpo illuminante Camelot-A / Only available for Camelot-A lighting fixture

CLP050 mensola singola o doppia / CLP050 single or double arm

CLP060 - CLP070 mensola singola, doppia o sfalsata / CLP060 - CLP070 single, double or split-level arm

Tipo di fissaggio: flangia o fondazione / Fixing type: flange or foundation

### Sbraccio // Extension

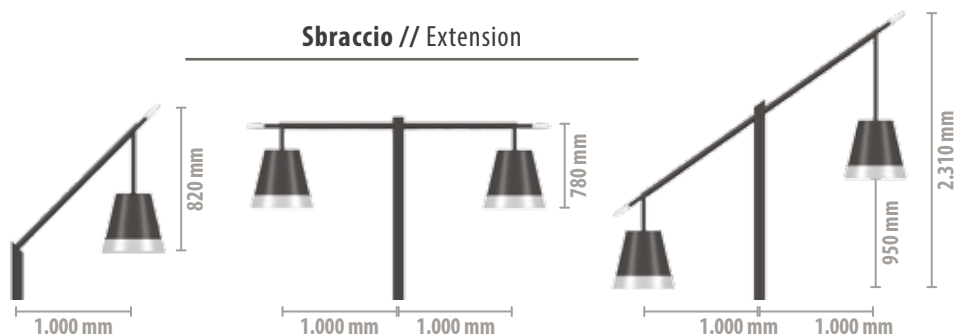





## CAMELOT WALL BRACKET

La mensola a muro “Camelot” riprende il design esclusivo e l’attenzione per gli aspetti cromatici della collezione, completandone l’offerta. È caratterizzata dalla colorazione dei terminali a LED e del cappello del corpo illuminante (grigio, rosso, giallo, blu o verde) ed è disponibile in un’unica variante geometrica e dimensionale.

*The “Camelot” wall bracket stems from the exclusive design and the attention to details which features the whole collection. The colours of the decorative LED tips and the lighting fixture (available in grey, red, yellow, blue or green) are the only customization options.*

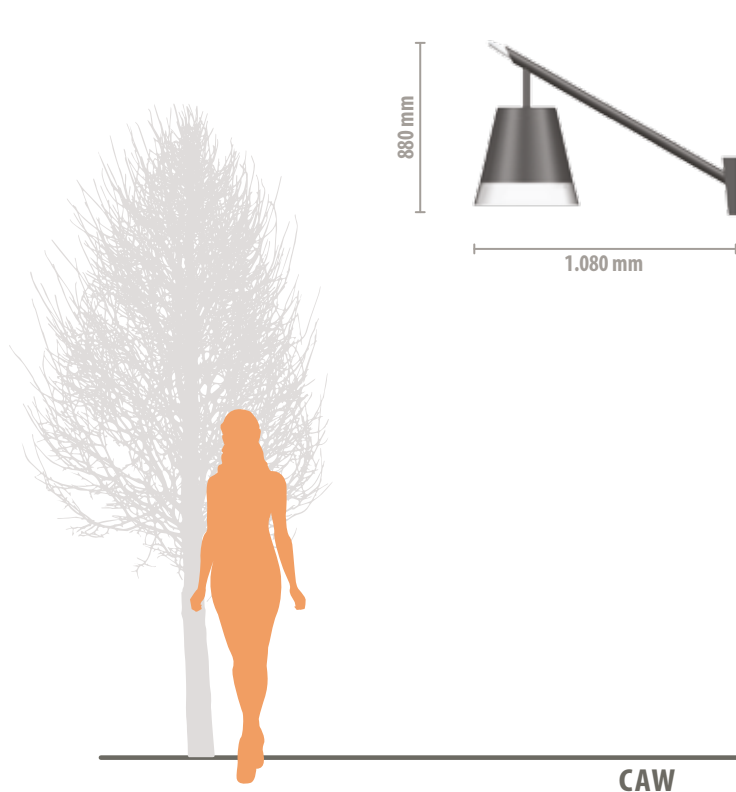

**illuminazione di arredo urbano di design //**  
*design urban lighting*







**Illuminazione di arredo  
di design //**  
*design urban lighting*

**CORPI ILLUMINANTI //** *lighting fixtures*

346 **MELDANS ARCADE**

350 **MELDANS**

**PALI //** *poles*

352 **MELDANS ROYAL POLE**

356 **MELDANS SAIL POLE**

**MENSOLE A MURO //** *wall brackets*

358 **MELDANS WALL BRACKET**

# M e l d a n s

Meldans, nato come elemento di illuminazione per i portici, ispira una linea completa di prodotti modellati intorno al vincolo dell'eccezione, per dare unicità e coerenza allo spazio urbano.

*Meldans was originally designed to complement porticoes and walkways. It then inspired a collection of solutions modelled around exception to the norm, in order to bring together the urban environment.*





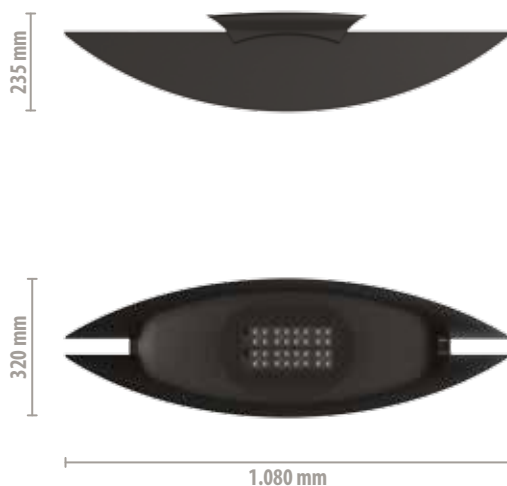

**MELDANS ARCADE**



**MSL  
GLASSED**

**Specifiche Tecniche // Technical Features**

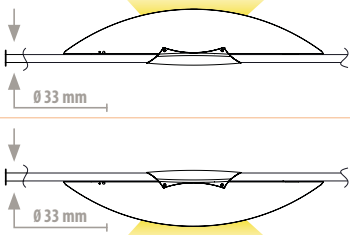
Corpo illuminante per portici / *Lighting fixtures for arcades*

<b>MATERIALE:</b>	<b>MATERIAL:</b>	 <b>TIMELESS</b>
pressofusione di alluminio, vetro.	die-cast aluminium, glass.	Apparecchio apribile e rigenerabile (componentistica interna sostituibile) senza utilizzo di utensili. <i>Tool-free openable fixture - Replaceable internal components without the need of tools.</i>
<b>TEMPERATURA DI COLORE // COLOUR TEMPERATURE</b>		<b>TIPO DI FISSAGGIO // FIXING TYPE</b>
2200K // 3000K // 4000K // 5700K		
<b>DIMMERABILE // DIMMABLE</b>		<b>A TIRANTE // TIE-ROD</b>
<b>SISTEMI OTTICI // OPTICAL SYSTEMS</b>		
 <p>· TYPE 1 ·    · TYPE 5 ·</p>		

Disponibile anche nella versione a scarica da 50 a 150 W // *Also available in 50 to 150W discharge lamp*

Per maggiori informazioni vedi scheda tecnica prodotto // *For more information see our product datasheet*

**illuminazione di arredo urbano di design //**  
*design urban lighting*











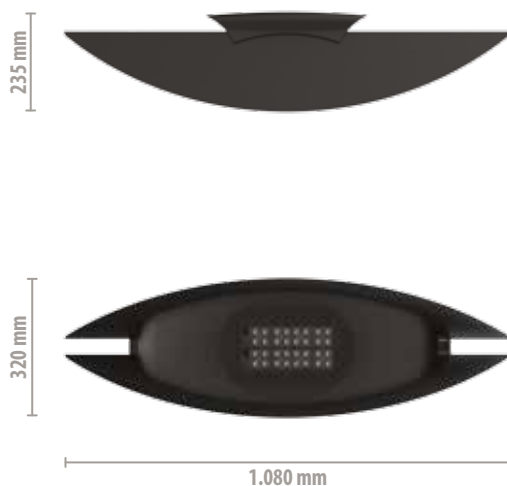

**MELDANS**

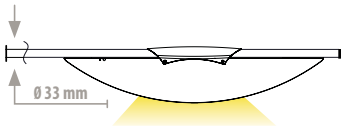

**MLL  
GLASSED**

**Specifiche Tecniche // Technical Features**

<b>MATERIALE:</b>	<b>MATERIAL:</b>	<b>TIMELESS</b>
pressofusione di alluminio, vetro.	die-cast aluminium, glass.	Apparecchio apribile e rigenerabile (componentistica interna sostituibile) senza utilizzo di utensili. <i>Tool-free openable fixture - Replaceable internal components without the need of tools.</i>
<b>TEMPERATURA DI COLORE // COLOUR TEMPERATURE</b>		<b>TIPO DI FISSAGGIO // FIXING TYPE</b>
2200K // 3000K // 4000K // 5700K		
<b>DIMMERABILE // DIMMABLE</b>		
<b>SISTEMI OTTICI // OPTICAL SYSTEMS</b>		
 <p>· TYPE 2 ·    · TYPE 3 ·</p>		<b>A PALO // POLE ATTACHEMENT</b>

Il corpo illuminante Meldans può essere installato solo sui pali e sulle mensole a muro della collezione // *Meldans fixture can only be installed on the poles and the wall brackets of the collection*

**Disponibile anche nella versione a scarica da 50 a 150 W // Also available in 50 to 150W discharge lamp**

Per maggiori informazioni vedi scheda tecnica prodotto // *For more information see our product datasheet*



## MELDANS ROYAL POLE

“Meldans Royal” è costituito da un palo cilindrico e da un sottile braccio, entrambi in acciaio. La curvatura elegante del palo si accentua in corrispondenza del sottile braccio di innesto con il corpo illuminante, generando un profilo sofisticato in grado di rendere unica l’illuminazione di parchi e giardini, centri storici e zone residenziali.

*“Meldans Royal” is made of a cylindrical pole and a thin arm, both in steel. The pole’s elegant curvature is emphasized in the point where it meets the lighting fixture, creating a sophisticated lighting effect in parks and gardens, historic town centers and residential areas.*

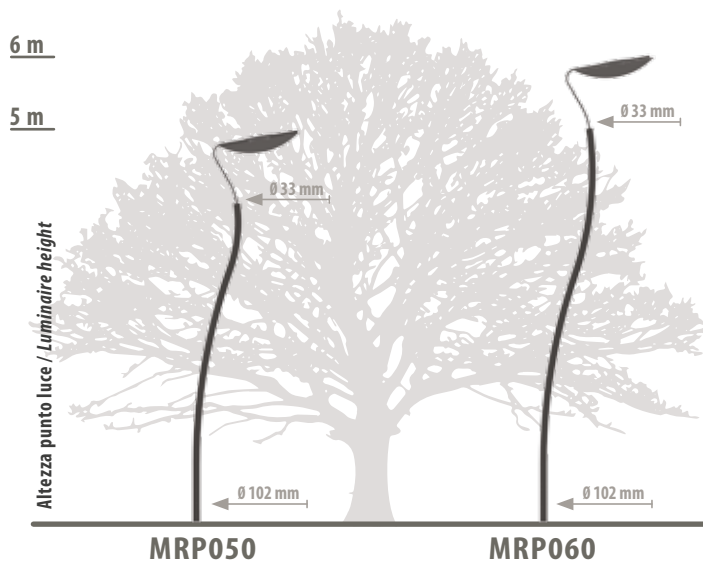

### **Versioni Disponibili // Available Versions**

Disponibile solo per corpo illuminante Meldans / Only available for Meldans lighting fixture

Tipo di fissaggio: flangia o fondazione / Fixing type: flange or foundation

**illuminazione di arredo urbano di design //**  
*design urban lighting*









## MELDANS SAIL POLE

“Meldans Sail”, imponente e maestoso come gli alberi maestri delle imbarcazioni, sfrutta appieno l'applicazione dei tiranti in acciaio inox. Il palo, conico senza saldature a vista, è disponibile in tre altezze e può essere completato con uno standardo personalizzabile.

*“Meldans Sail”, imposing and majestic like ships’ mainmasts, takes full advantage of the application of steel tie rods. The conical light pole without visible welding is available in three heights and can be completed by a customisable banner.*

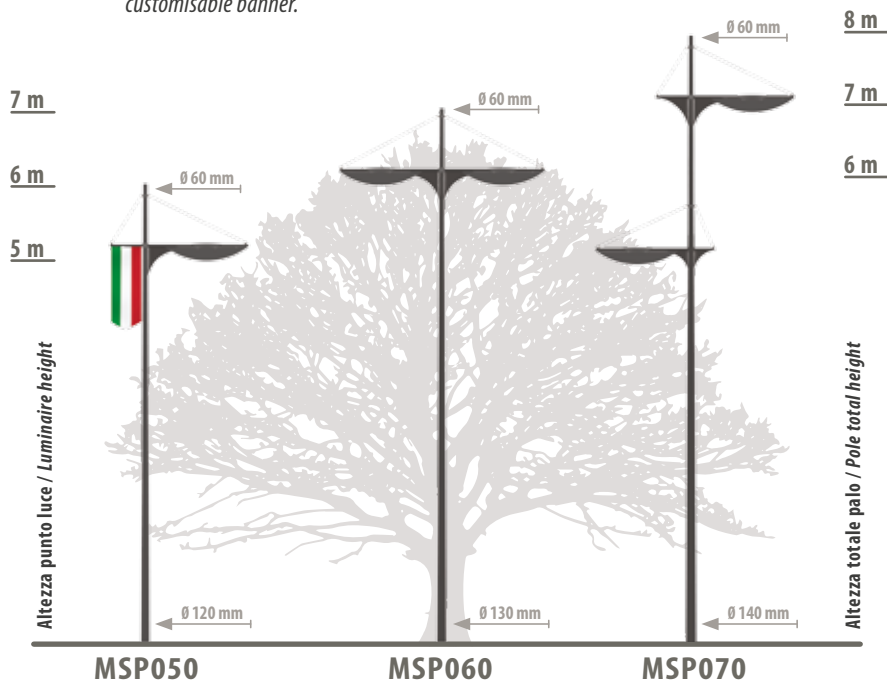

### Versioni Disponibili // Available Versions

Disponibile solo per corpo illuminante Meldans / Only available for Meldans lighting fixture

MSP050 - MSP060 mensola singola o doppia / MSP050 - MSP060 single or double arm

MSP070 mensola singola, doppia o sfalsata / MSP070 single, double or split-level arm

Stendardo personalizzabile / Customizable banner

Tipo di fissaggio: flangia o fondazione / Fixing type: flange or foundation

### Sbraccio // Extension

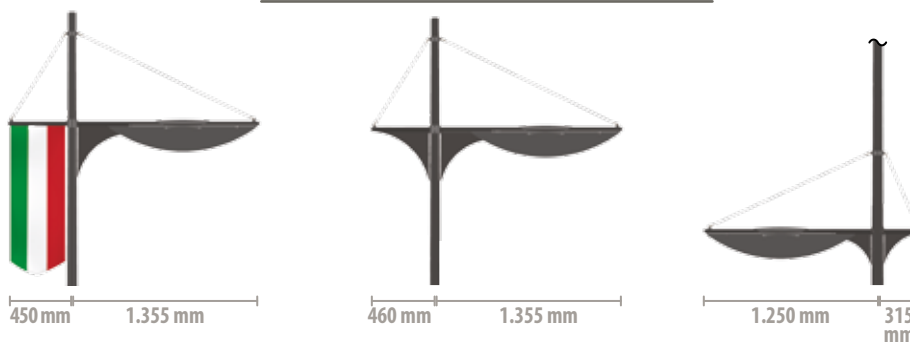

Per approfondimenti tecnici sul corpo illuminante vedi p. 350 / Refer to p. 350 for more detailed technical information on the lighting fixture



## MELDANS WALL BRACKET

La mensola "Meldans" completa la collezione riprendendone il design e le volumetrie. È disponibile in unica versione, ideale per dare personalità e carattere all'ambiente che la ospita.

*The "Meldans" wall bracket completes the collection and enhances it with a design inspired by the sense of volume of the original. The wall bracket is available in one version. It is the ideal solution to give personality and character to the surroundings.*

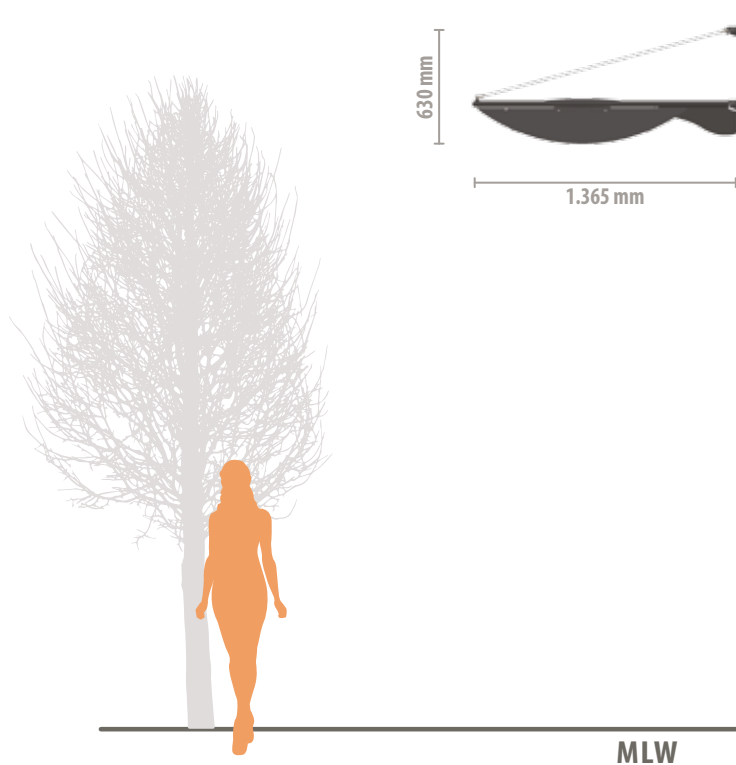

**illuminazione di arredo urbano di design //**  
*design urban lighting*









**Illuminazione di arredo  
di design //**  
*design urban lighting*

**CORPI ILLUMINANTI //** *lighting fixtures*

364

**YUMI**

**PALI //** *poles*

366

**YUMI POLE**

# Y u m i

Yumi prende il nome dall'antico e lungo arco dei samurai giapponesi.

La forma prescelta, sottile e ricurva, è eco dell'essenzialità orientale.

*Yumi collection takes its name from the long and ancient Japanese samurai bow. The thin and sleek design traits are inspired by eastern philosophy.*

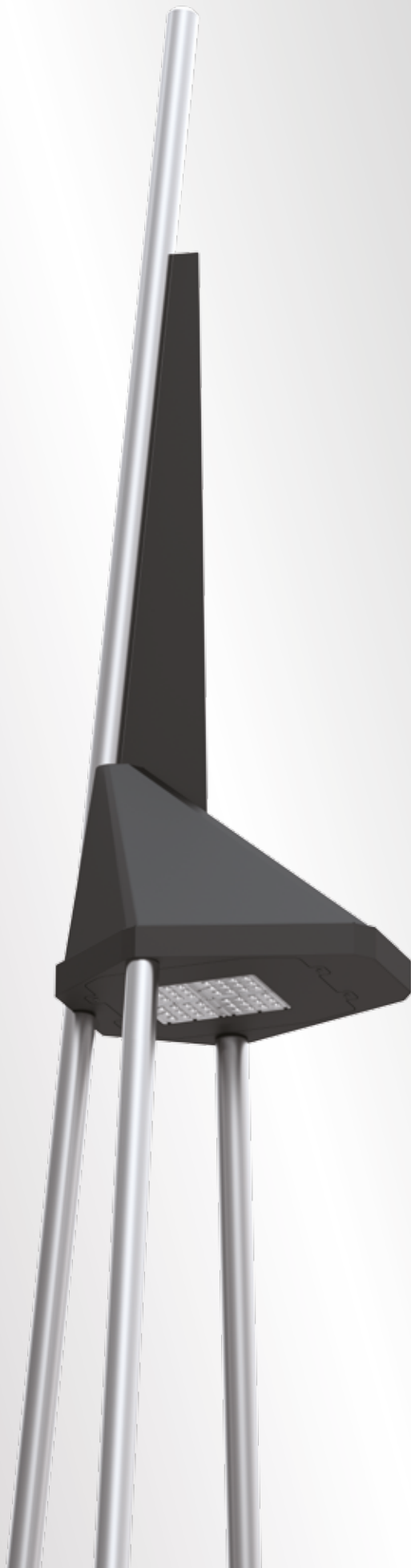

**YUMI**

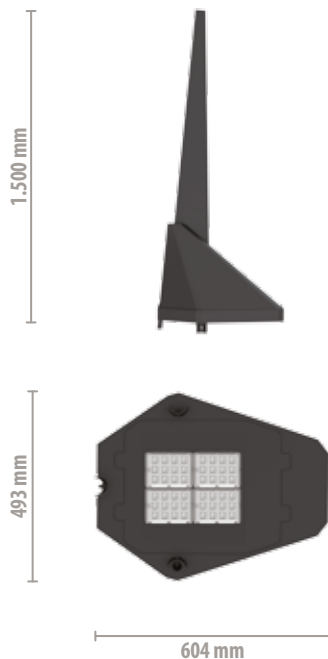

**YUM  
GLASS-FREE**

**Specifiche Tecniche // Technical Features**

<b>MATERIALE:</b>	<b>MATERIAL:</b>	<b>TIMELESS</b>
acciaio.	steel.	<p>Apparecchio apribile e rigenerabile (componentistica interna sostituibile) senza utilizzo di utensili.  <i>Tool-free openable fixture - Replaceable internal components without the need of tools.</i></p>
<b>TEMPERATURA DI COLORE // COLOUR TEMPERATURE</b>		<b>TIPO DI FISSAGGIO // FIXING TYPE</b>
2200K // 3000K // 4000K // 5700K		
<b>DIMMERABILE // DIMMABLE</b>		
<b>SISTEMI OTTICI // OPTICAL SYSTEMS</b>		
<p>• TYPE 2 •    • TYPE 3 •    • TYPE 5 •</p>		

Il corpo illuminante Yumi può essere installato solo sul palo della collezione //  
*Yumi fixture can only be installed on the pole of the collection*

**Disponibile anche nella versione a scarica da 100 a 400 W // Also available in 100 to 400W discharge lamp**

Per maggiori informazioni vedi scheda tecnica prodotto // *For more information see our product datasheet*





## YUMI POLE

Il sistema di illuminazione “Yumi” nasce dal desiderio di conferire eleganza allo spazio urbano, con un prodotto dal profilo composto e originale. La scocca alla base, dalla quale si dipartono i tre lunghi tubi in acciaio che sorreggono il corpo illuminante, può essere completata con l’aggiunta dell’apposito vaso-fioriera o cestino portarifiuti.

*“Yumi” lighting system was inspired by the desire to give the urban environment a calm and collected outlook with an original design. Three long steel tubes depart from the base frame which can be complemented with a flower pot or a litter bin.*

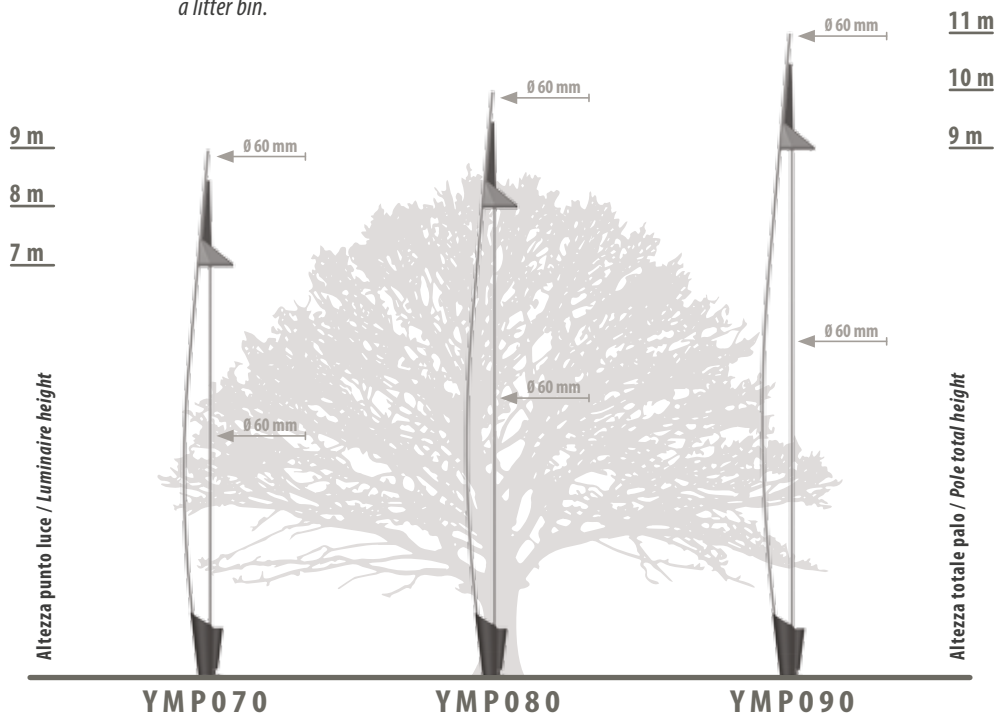

### Versioni Disponibili // Available Versions

Disponibile solo per corpo illuminante Yumi / Only available for Yumi lighting fixture

Disponibile versione base standard, vaso-fioriera o cestino integrato / Available in the basic standard version or with flower pot/litter bin supplement

Tipo di fissaggio: flangia / Fixing type: flange

### Base Palo // Pole Base

**BASE STANDARD**  
BASE STANDARD

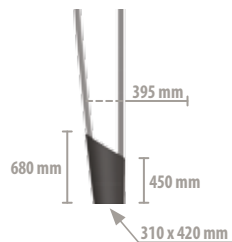

**VASO-FIORIERA o CESTINO INTEGRATO**  
INTEGRATED FLOWER POT or LITTER BIN

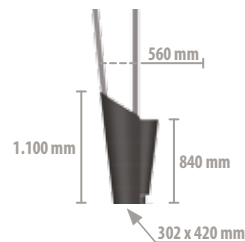

**illuminazione di arredo urbano di design //**  
*design urban lighting*







**Illuminazione artistica //**  
*classic lighting*

**CORPI ILLUMINANTI // lighting fixtures**

- 372 **OSLO SMALL**
- 374 **OSLO LARGE**
- 376 **JUN SMALL**
- 378 **JUN LARGE**
- 380 **LAMPARA SMALL**
- 382 **LAMPARA LARGE**
- 384 **GAMMA SMALL**
- 386 **GAMMA LARGE**
- 388 **DIAMANTE**
- 390 **PIATTELLO**
- 392 **ALD**
- 394 **LTD**
- 396 **NOTTINGHAM**
- 398 **GRANADA**
- 400 **LQ093**
- 402 **LQ094**
- 404 **LQ091**
- 406 **CROTONE**
- 408 **COSENZA**
- 410 **MINA**



---

# corpi illuminanti artistici

## *classic lighting fixtures*

Il design della memoria storica e il sapiente utilizzo dei sistemi ottici custoditi in prodotti eleganti per un'illuminazione di qualità e di alto valore estetico.

*The design of historical memory and the skillful use of optical systems housed in elegant products create quality lighting with a high aesthetic value.*



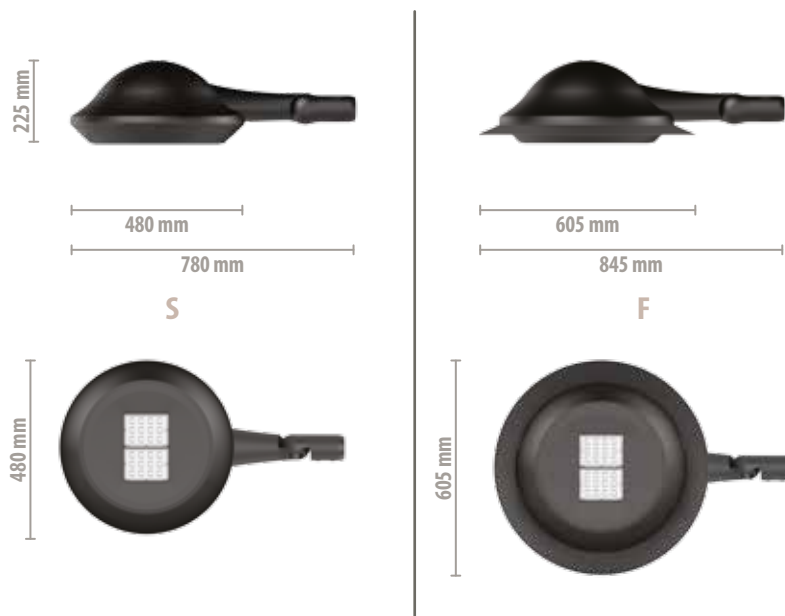

**OSLO SMALL**

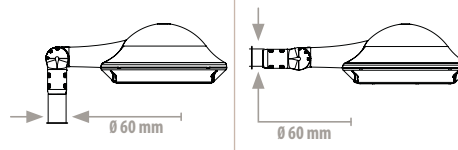

**OSLS  
GLASS-FREE**

**Specifiche Tecniche // Technical Features**

<b>MATERIALE:</b> pressofusione di alluminio.	<b>MATERIAL:</b> die-cast aluminium.	 <b>TIMELESS</b> Apparecchio apribile e rigenerabile (componentistica interna sostituibile) senza utilizzo di utensili. <i>Tool-free openable fixture - Replaceable internal components without the need of tools.</i>
<b>TEMPERATURA DI COLORE // COLOUR TEMPERATURE</b> 2200K // 3000K // 4000K // 5700K		
<b>DIMMERABILE // DIMMABLE</b>		<b>TIPO DI FISSAGGIO // FIXING TYPE</b> 
<b>SISTEMI OTTICI // OPTICAL SYSTEMS</b>  · TYPE 2 ·    · TYPE 3 ·		
		<b>LATERALE // SIDE</b> Regolabile con step da 2,5° <i>Adjustable with 2,5° steps</i>  -30°

Disponibile anche nella versione a scarica da 50 a 150 W // Also available in 50 to 150W discharge lamp

Per maggiori informazioni vedi scheda tecnica prodotto // For more information see our product datasheet



**OSLO LARGE**

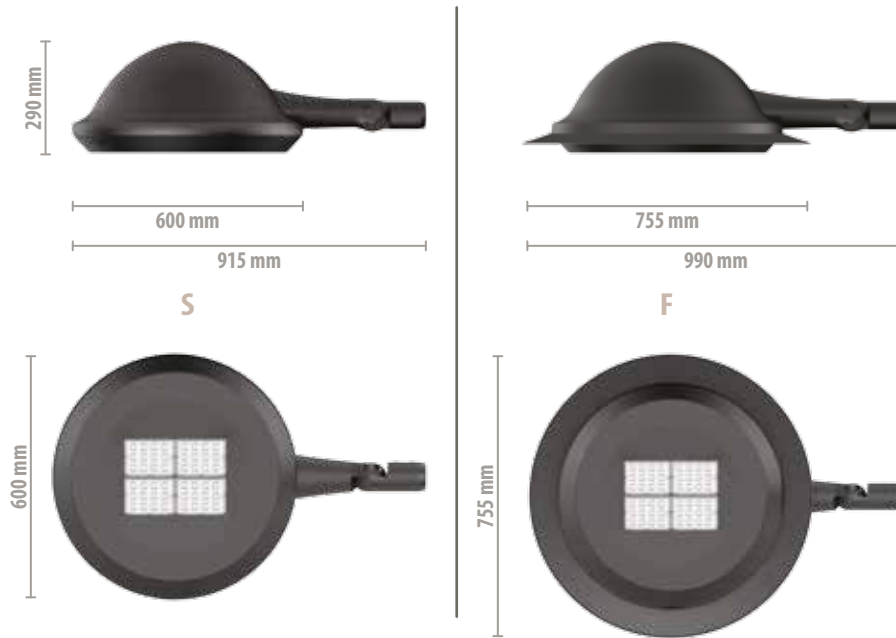

**OSLL  
GLASS-FREE**

**Specifiche Tecniche // Technical Features**

<b>MATERIALE:</b>	<b>MATERIAL:</b>	<b>TIMELESS</b>	
pressofusione di alluminio.	die-cast aluminium.	Apparecchio apribile e rigenerabile (componentistica interna sostituibile) senza utilizzo di utensili. <i>Tool-free openable fixture - Replaceable internal components without the need of tools.</i>	
<b>TEMPERATURA DI COLORE // COLOUR TEMPERATURE</b>		<b>TIPO DI FISSAGGIO // FIXING TYPE</b>	
2200K // 3000K // 4000K // 5700K			
<b>DIMMERABILE // DIMMABLE</b>		<b>TESTA-PALO // POLE-TOP</b>	
<b>SISTEMI OTTICI // OPTICAL SYSTEMS</b>		<b>LATERALE // SIDE</b>	
<p>• TYPE 2 •    • TYPE 3 •</p>		Regolabile con step da 2,5° <i>Adjustable with 2,5° steps</i> +30°	
		Regolabile con step da 2,5° <i>Adjustable with 2,5° steps</i> -30°	

Disponibile anche nella versione a scarica da 100 a 400 W // Also available in 100 to 400W discharge lamp

Per maggiori informazioni vedi scheda tecnica prodotto // For more information see our product datasheet





**JUN SMALL**



**JUNS  
GLASS-FREE**

**Specifiche Tecniche // Technical Features**

<b>MATERIALE:</b>	<b>MATERIAL:</b>
pressofusione di alluminio.	die-cast aluminium.

<b>TEMPERATURA DI COLORE // COLOUR TEMPERATURE</b>
2200K // 3000K // 4000K // 5700K

<b>DIMMERABILE // DIMMABLE</b>
--------------------------------

<b>SISTEMI OTTICI // OPTICAL SYSTEMS</b>
--



	<b>TIMELESS</b>
Apparecchio apribile e rigenerabile (componentistica interna sostituibile) senza utilizzo di utensili. <i>Tool-free openable fixture - Replaceable internal components without the need of tools.</i>	

<b>TIPO DI FISSAGGIO // FIXING TYPE</b>		
<b>A</b>	<b>B</b>	<b>C-Q</b>
<b>SOSPENSIONE // SUSPENDED</b>		
<b>TESATA DI FUNE // WIRE SYSTEM</b>	<b>TESTA-PALO // POLE-TOP</b>	<b>TESTA-PALO // POLE-TOP</b>

<b>DIFFUSORI // DIFFUSERS</b>
<b>ALBA</b> A • B • C • Q
<b>TONDA</b> A • B • C • Q

**Su richiesta:**  
policarbonato ghiacciato o trasparente.  
**On request:**  
frosted or transparent polycarbonate.

Disponibile anche nella versione a scarica da 50 a 150 W // Also available in 50 to 150W discharge lamp

Per maggiori informazioni vedi scheda tecnica prodotto // For more information see our product datasheet



**JUN LARGE**

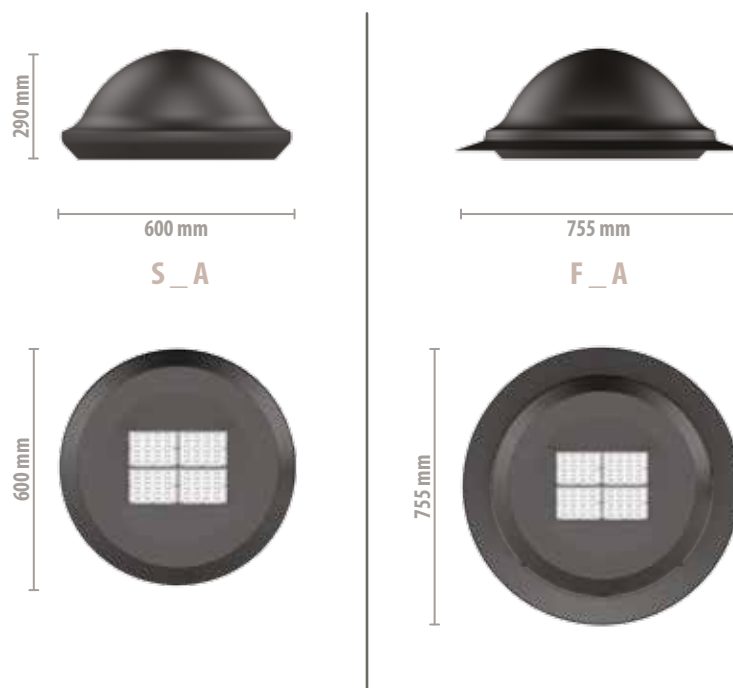

**JUNL  
GLASS-FREE**

**Specifiche Tecniche // Technical Features**

<b>MATERIALE:</b> pressofusione di alluminio.	<b>MATERIAL:</b> die-cast aluminium.		
<b>TEMPERATURA DI COLORE // COLOUR TEMPERATURE</b> 2200K // 3000K // 4000K // 5700K			
<b>DIMMERABILE // DIMMABLE</b>			
<b>SISTEMI OTTICI // OPTICAL SYSTEMS</b>			
• TYPE 1 •	• TYPE 2 •	• TYPE 3 •	• TYPE 5 •

<b>TIMELESS</b> Apparecchio apribile e rigenerabile (componentistica interna sostituibile) senza utilizzo di utensili. <i>Tool-free openable fixture - Replaceable internal components without the need of tools.</i>	
<b>TIPO DI FISSAGGIO // FIXING TYPE</b>	
<b>SOSPENSIONE // SUSPENDED</b>	<b>TESATA DI FUNE // WIRE SYSTEM</b>

<b>DIFFUSORI // DIFFUSERS</b>
ALBA
TONDA
<b>Su richiesta:</b> policarbonato ghiacciato o trasparente. <b>On request:</b> frosted or transparent polycarbonate.

Disponibile anche nella versione a scarica da 100 a 400 W // Also available in 100 to 400W discharge lamp

Per maggiori informazioni vedi scheda tecnica prodotto // For more information see our product datasheet









**LAMPARA SMALL**

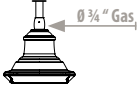
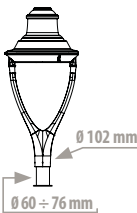
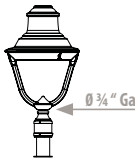
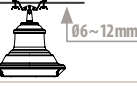
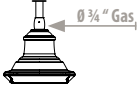
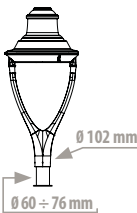
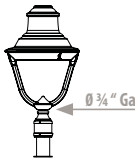
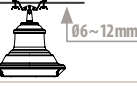
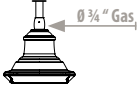
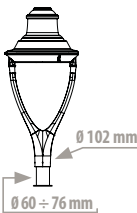
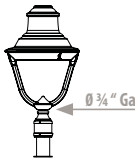
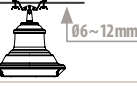

**LAMS  
GLASS-FREE**

**Specifiche Tecniche // Technical Features**

<b>MATERIALE:</b>	<b>MATERIAL:</b>	 <b>TIMELESS</b> Apparecchio apribile e rigenerabile (componentistica interna sostituibile) senza utilizzo di utensili. <i>Tool-free openable fixture - Replaceable internal components without the need of tools.</i>	<b>DIFFUSORI // DIFFUSERS</b>									
pressofusione di alluminio.	die-cast aluminium.		 <p><b>ALBA</b> A • B • C • Q</p>									
<b>TEMPERATURA DI COLORE // COLOUR TEMPERATURE</b> 2200K // 3000K // 4000K // 5700K		<b>TIPO DI FISSAGGIO // FIXING TYPE</b>	 <p><b>TONDA</b> A • B • C • Q</p>									
<b>DIMMERABILE // DIMMABLE</b>		<table border="1"> <thead> <tr> <th data-bbox="619 1554 775 1628">A</th> <th data-bbox="775 1554 932 1628">B</th> <th data-bbox="932 1554 1090 1628">C • Q</th> </tr> </thead> <tbody> <tr> <td data-bbox="619 1628 775 1755">  <p>Ø 3/4" Gas</p> </td> <td data-bbox="775 1628 932 1755">  <p>Ø 102 mm Ø 60 ÷ 76 mm</p> </td> <td data-bbox="932 1628 1090 1755">  <p>Ø 3/4" Gas</p> </td> </tr> <tr> <td data-bbox="619 1755 775 1806">  <p>Ø 6~12 mm</p> </td> <td data-bbox="775 1755 932 1806"> <b>TESTA-PALO // POLE-TOP</b> </td> <td data-bbox="932 1755 1090 1806"> <b>TESTA-PALO // POLE-TOP</b> </td> </tr> </tbody> </table>	A	B	C • Q	 <p>Ø 3/4" Gas</p>	 <p>Ø 102 mm Ø 60 ÷ 76 mm</p>	 <p>Ø 3/4" Gas</p>	 <p>Ø 6~12 mm</p>	<b>TESTA-PALO // POLE-TOP</b>	<b>TESTA-PALO // POLE-TOP</b>	<p><b>Su richiesta:</b> policarbonato ghiacciato o trasparente. <i>On request:</i> frosted or transparent polycarbonate.</p>
A	B	C • Q										
 <p>Ø 3/4" Gas</p>	 <p>Ø 102 mm Ø 60 ÷ 76 mm</p>	 <p>Ø 3/4" Gas</p>										
 <p>Ø 6~12 mm</p>	<b>TESTA-PALO // POLE-TOP</b>	<b>TESTA-PALO // POLE-TOP</b>										
<b>SISTEMI OTTICI // OPTICAL SYSTEMS</b>												
 <p>• TYPE 1 •   • TYPE 2 •   • TYPE 3 •   • TYPE 5 •</p>												

Disponibile anche nella versione a scarica da 50 a 150 W // Also available in 50 to 150W discharge lamp

Per maggiori informazioni vedi scheda tecnica prodotto // For more information see our product datasheet



**LAMPARA LARGE**



**L A M L  
GLASS-FREE**

**Specifiche Tecniche // Technical Features**

<b>MATERIALE:</b> pressofusione di alluminio.	<b>MATERIAL:</b> die-cast aluminium.
<b>TEMPERATURA DI COLORE // COLOUR TEMPERATURE</b> 2200K // 3000K // 4000K // 5700K	
<b>DIMMERABILE // DIMMABLE</b>	
<b>SISTEMI OTTICI // OPTICAL SYSTEMS</b>	
• TYPE 1 •	• TYPE 2 •
• TYPE 3 •	• TYPE 5 •

	<b>TIMELESS</b> Apparecchio apribile e rigenerabile (componentistica interna sostituibile) senza utilizzo di utensili. <i>Tool-free openable fixture - Replaceable internal components without the need of tools.</i>
<b>TIPO DI FISSAGGIO // FIXING TYPE</b>	
<b>SOSPENSIONE // SUSPENDED</b>	<b>TESATA DI FUNE // WIRE SYSTEM</b>

<b>DIFFUSORI // DIFFUSERS</b>
ALBA
TONDA
<b>Su richiesta:</b> policarbonato ghiacciato o trasparente. <b>On request:</b> frosted or transparent polycarbonate.

Disponibile anche nella versione a scarica da 100 a 400 W // Also available in 100 to 400W discharge lamp

Per maggiori informazioni vedi scheda tecnica prodotto // For more information see our product datasheet



**GAMMA SMALL**

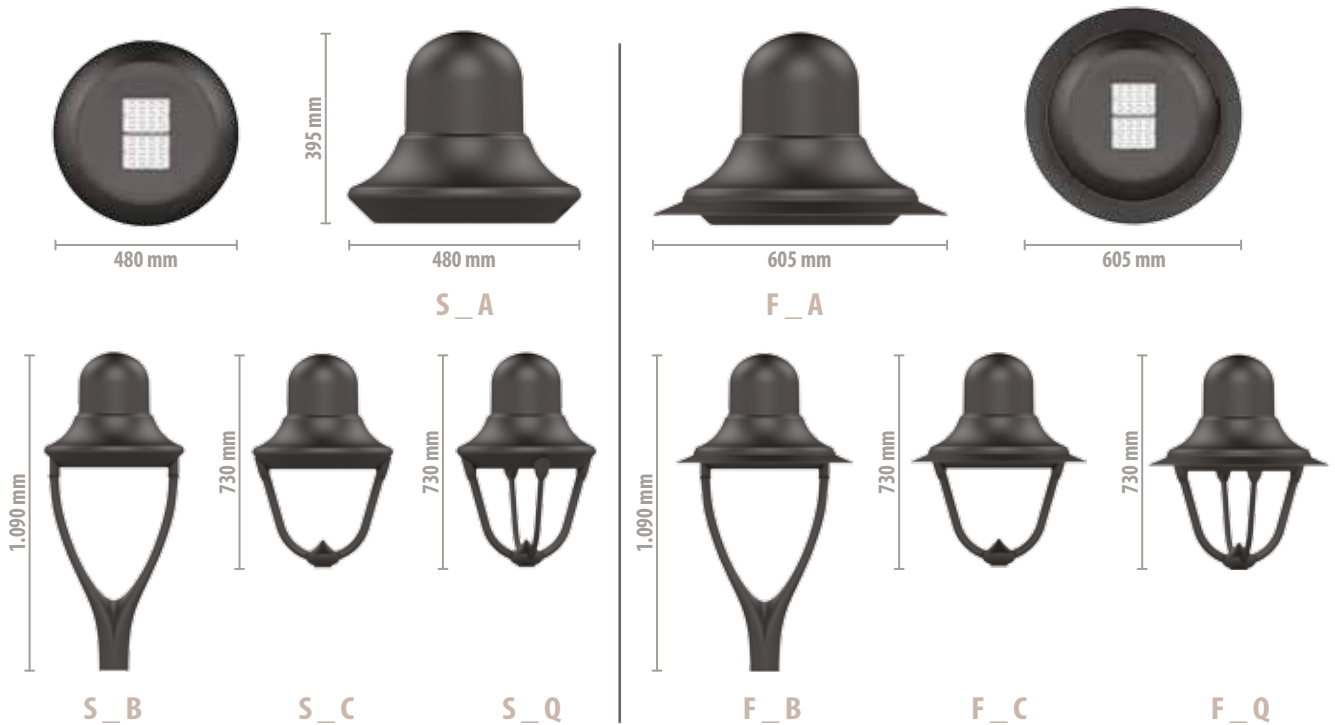

**GAMS  
GLASS-FREE**

**Specifiche Tecniche // Technical Features**

<p><b>MATERIALE:</b></p>	<p><b>MATERIAL:</b></p>	<p><b>TIMELESS</b></p>	<p><b>DIFFUSORI // DIFFUSERS</b></p>	
<p>pressofusione di alluminio.</p>	<p>die-cast aluminium.</p>	<p>Apparecchio apribile e rigenerabile (componentistica interna sostituibile) senza utilizzo di utensili. <i>Tool-free openable fixture - Replaceable internal components without the need of tools.</i></p>	<p><b>ALBA</b> A • B • C • Q</p> <p><b>TONDA</b> A • B • C • Q</p>	
<p><b>TEMPERATURA DI COLORE // COLOUR TEMPERATURE</b></p>		<p><b>TIPO DI FISSAGGIO // FIXING TYPE</b></p>		
<p>2200K // 3000K // 4000K // 5700K</p>		<p><b>A</b></p>	<p><b>B</b></p>	<p><b>C • Q</b></p>
<p><b>DIMMERABILE // DIMMABLE</b></p>		<p>SOSPENSIONE // SUSPENDED</p> <p>Ø 3/4" Gas</p>	<p>TESTA-PALO // POLE-TOP</p> <p>Ø 102 mm</p>	<p>TESTA-PALO // POLE-TOP</p> <p>Ø 3/4" Gas</p>
<p><b>SISTEMI OTTICI // OPTICAL SYSTEMS</b></p>		<p>TESATA DI FUNE // WIRE SYSTEM</p> <p>Ø 6~12 mm</p>	<p>TESTA-PALO // POLE-TOP</p> <p>Ø 60 ÷ 76 mm</p>	<p>TESTA-PALO // POLE-TOP</p>
<p>• TYPE 1 •   • TYPE 2 •   • TYPE 3 •   • TYPE 5 •</p>		<p><b>Su richiesta:</b> policarbonato ghiacciato o trasparente. <b>On request:</b> frosted or transparent polycarbonate.</p>		

Disponibile anche nella versione a scarica da 50 a 150 W // Also available in 50 to 150W discharge lamp

Per maggiori informazioni vedi scheda tecnica prodotto // For more information see our product datasheet





**GAMMA LARGE**

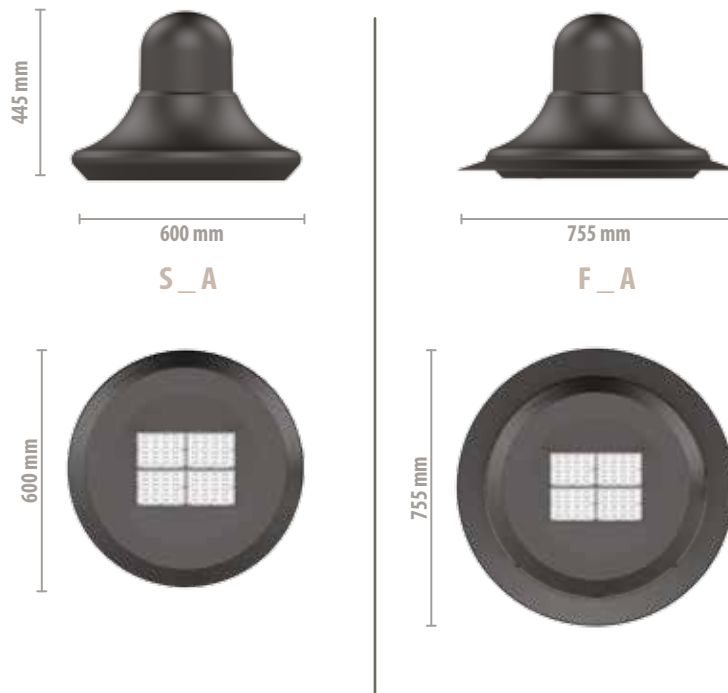

**GAML  
GLASS-FREE**

**Specifiche Tecniche // Technical Features**

<b>MATERIALE:</b>	<b>MATERIAL:</b>
pressofusione di alluminio.	die-cast aluminium.

<b>TEMPERATURA DI COLORE // COLOUR TEMPERATURE</b>
2200K // 3000K // 4000K // 5700K

<b>DIMMERABILE // DIMMABLE</b>
--------------------------------

<b>SISTEMI OTTICI // OPTICAL SYSTEMS</b>
--

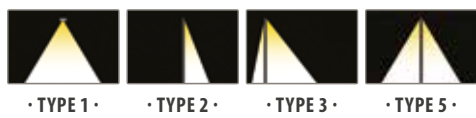

	<b>TIMELESS</b>
Apparecchio apribile e rigenerabile (componentistica interna sostituibile) senza utilizzo di utensili. <i>Tool-free openable fixture - Replaceable internal components without the need of tools.</i>	

<b>TIPO DI FISSAGGIO // FIXING TYPE</b>
---

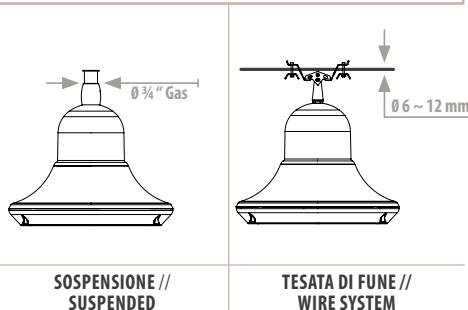

<b>DIFFUSORI // DIFFUSERS</b>
-------------------------------



**Su richiesta:**  
policarbonato ghiacciato o trasparente.  
**On request:**  
frosted or transparent polycarbonate.

Disponibile anche nella versione a scarica da 100 a 400 W // Also available in 100 to 400W discharge lamp

Per maggiori informazioni vedi scheda tecnica prodotto // For more information see our product datasheet



**DIAMANTE**

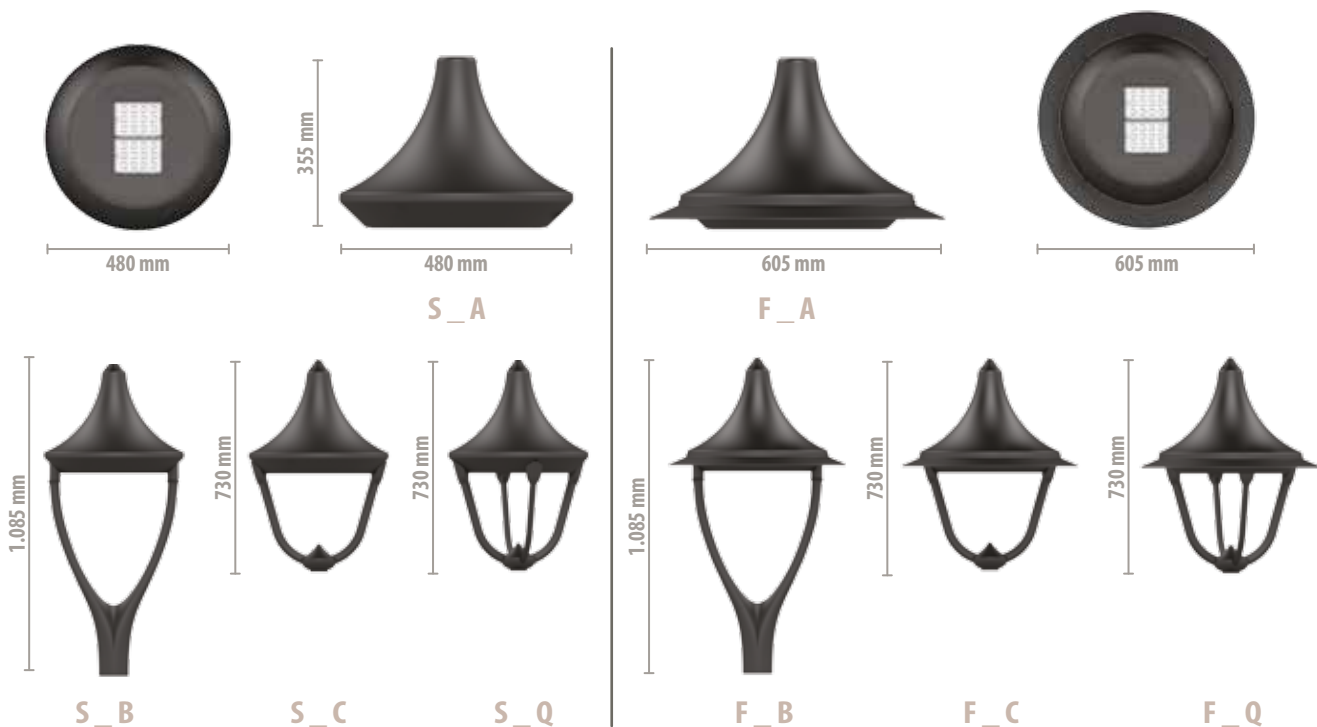

**DIA  
GLASS-FREE**

**Specifiche Tecniche // Technical Features**

<b>MATERIALE:</b>	<b>MATERIAL:</b>
-------------------	------------------

pressofusione di alluminio.

die-cast aluminium.

<b>TEMPERATURA DI COLORE // COLOUR TEMPERATURE</b>
--

2200K // 3000K // 4000K // 5700K

<b>DIMMERABILE // DIMMABLE</b>
--------------------------------

<b>SISTEMI OTTICI // OPTICAL SYSTEMS</b>
--



• TYPE 1 • • TYPE 2 • • TYPE 3 • • TYPE 5 •

	<b>TIMELESS</b>
--	-----------------

Apparecchio apribile e rigenerabile (componentistica interna sostituibile) senza utilizzo di utensili.  
Tool-free openable fixture - Replaceable internal components without the need of tools.

<b>TIPO DI FISSAGGIO // FIXING TYPE</b>		
<b>A</b>	<b>B</b>	<b>C-Q</b>

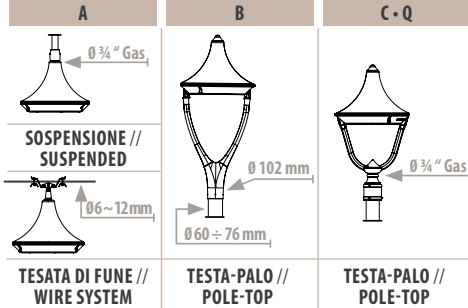

<b>DIFFUSORI // DIFFUSERS</b>
-------------------------------

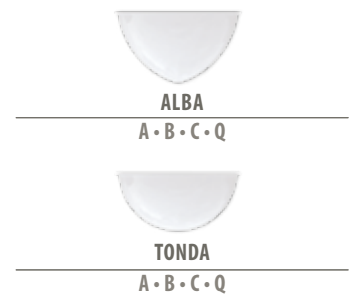

**Su richiesta:**  
policarbonato ghiacciato o trasparente.  
**On request:**  
frosted or transparent polycarbonate.

Disponibile anche nella versione a scarica da 50 a 150 W // Also available in 50 to 150W discharge lamp

Per maggiori informazioni vedi scheda tecnica prodotto // For more information see our product datasheet





**PIATTELLO**

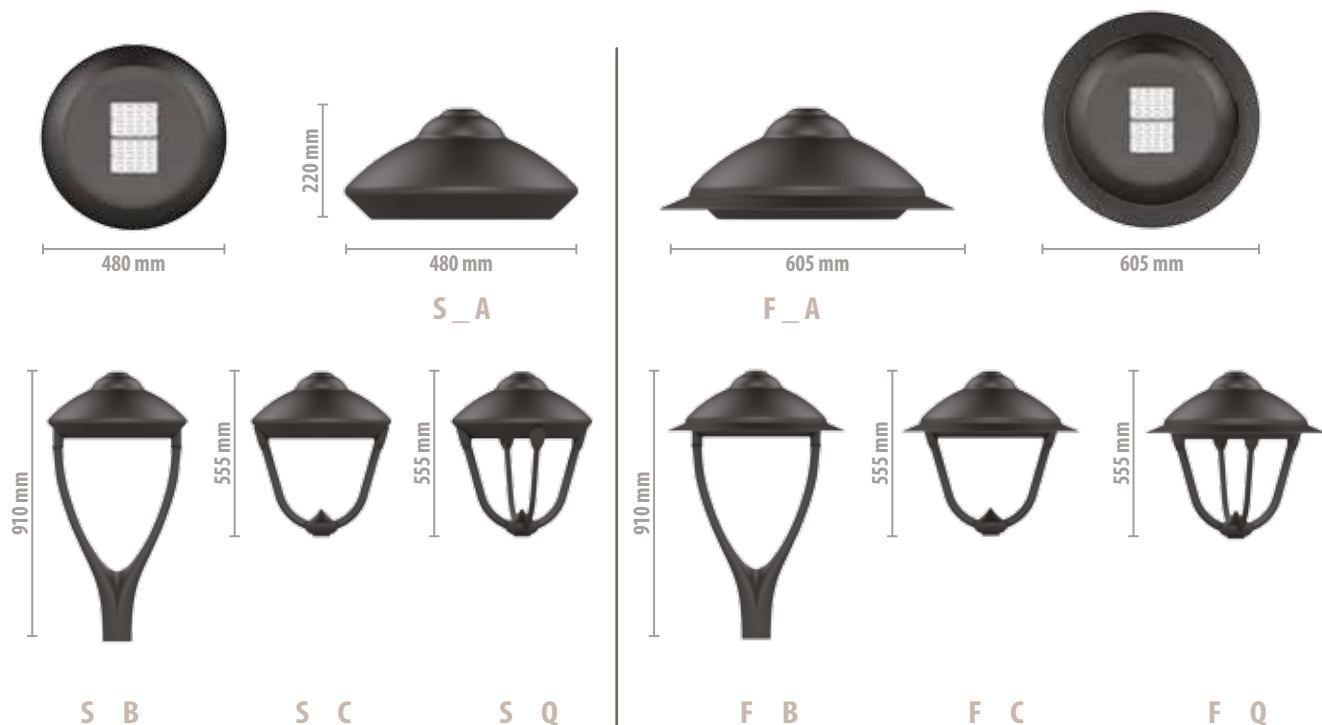

**PIA  
GLASS-FREE**

**Specifiche Tecniche // Technical Features**

<b>MATERIALE:</b>	<b>MATERIAL:</b>
pressofusione di alluminio.	die-cast aluminium.

<b>TEMPERATURA DI COLORE // COLOUR TEMPERATURE</b>
2200K // 3000K // 4000K // 5700K

<b>DIMMERABILE // DIMMABLE</b>
--------------------------------

<b>SISTEMI OTTICI // OPTICAL SYSTEMS</b>
--



	<b>TIMELESS</b>
Apparecchio apribile e rigenerabile (componentistica interna sostituibile) senza utilizzo di utensili. <i>Tool-free openable fixture - Replaceable internal components without the need of tools.</i>	

<b>TIPO DI FISSAGGIO // FIXING TYPE</b>		
A	B	C-Q
<b>SOSPENSIONE // SUSPENDED</b>	<b>TESTA-PALO // POLE-TOP</b>	<b>TESTA-PALO // POLE-TOP</b>
<b>TESATA DI FUNE // WIRE SYSTEM</b>		

<b>DIFFUSORI // DIFFUSERS</b>
<b>ALBA</b> A • B • C • Q
<b>TONDA</b> A • B • C • Q

**Su richiesta:**  
policarbonato ghiacciato o trasparente.  
**On request:**  
frosted or transparent polycarbonate.

Disponibile anche nella versione a scarica da 50 a 150 W // Also available in 50 to 150W discharge lamp

Per maggiori informazioni vedi scheda tecnica prodotto // For more information see our product datasheet



**ALD**

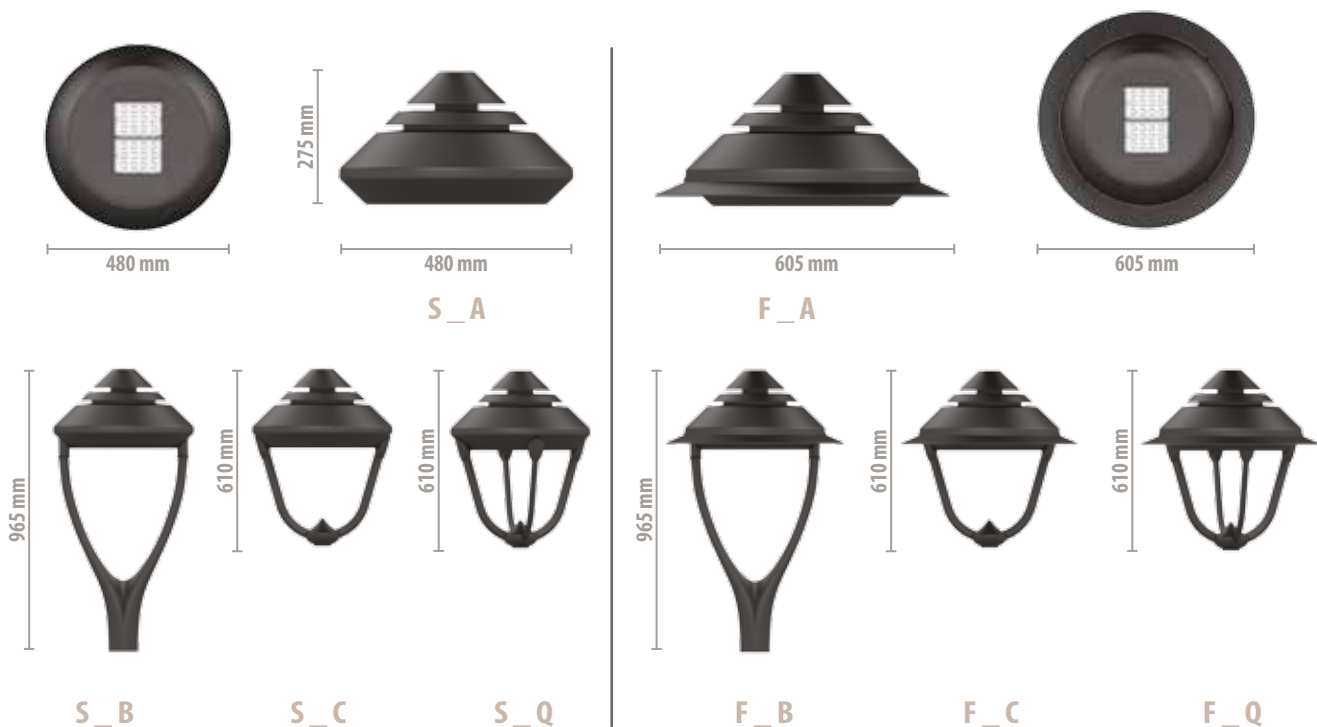

**ALD  
GLASS-FREE**

**Specifiche Tecniche // Technical Features**

<b>MATERIALE:</b> pressofusione di alluminio.	<b>MATERIAL:</b> die-cast aluminium.
<b>TEMPERATURA DI COLORE // COLOUR TEMPERATURE</b> 2200K // 3000K // 4000K // 5700K	
<b>DIMMERABILE // DIMMABLE</b>	
<b>SISTEMI OTTICI // OPTICAL SYSTEMS</b>	
• TYPE 1 •	• TYPE 2 •
• TYPE 3 •	• TYPE 5 •

<b>TIMELESS</b> Apparecchio apribile e rigenerabile (componentistica interna sostituibile) senza utilizzo di utensili. <i>Tool-free openable fixture - Replaceable internal components without the need of tools.</i>		
<b>TIPO DI FISSAGGIO // FIXING TYPE</b>		
<b>A</b>	<b>B</b>	<b>C-Q</b>
<b>SOSPENSIONE // SUSPENDED</b> Ø 3/4" Gas, ↑ Ø 6 ~ 12 mm	<b>TESTA-PALO // POLE-TOP</b> Ø 102 mm, Ø 60 ÷ 76 mm	<b>TESTA-PALO // POLE-TOP</b> Ø 3/4" Gas
<b>TESATA DI FUNE // WIRE SYSTEM</b>		

<b>DIFFUSORI // DIFFUSERS</b>
<b>ALBA</b> A • B • C • Q
<b>TONDA</b> A • B • C • Q
<b>Su richiesta:</b> policarbonato ghiacciato o trasparente. <i>On request:</i> frosted or transparent polycarbonate.

Disponibile anche nella versione a scarica da 50 a 150 W // Also available in 50 to 150W discharge lamp

Per maggiori informazioni vedi scheda tecnica prodotto // For more information see our product datasheet



**LTD**



695 mm

S\_F



695 mm

S\_G



900 mm

S\_L



900 mm

S\_M



480 mm

**LTD  
GLASS-FREE**

**Specifiche Tecniche // Technical Features**

<b>MATERIALE:</b>	<b>MATERIAL:</b>
-------------------	------------------

pressofusione di alluminio.

die-cast aluminium.

<b>TEMPERATURA DI COLORE // COLOUR TEMPERATURE</b>
--

2200K // 3000K // 4000K // 5700K

<b>DIMMERABILE // DIMMABLE</b>
--------------------------------

<b>SISTEMI OTTICI // OPTICAL SYSTEMS</b>
--



• TYPE 1 •

• TYPE 2 •

• TYPE 3 •

• TYPE 5 •

	<b>TIMELESS</b>
--	-----------------

Apparecchio apribile e rigenerabile (componentistica interna sostituibile) senza utilizzo di utensili.  
*Tool-free openable fixture - Replaceable internal components without the need of tools.*

<b>TIPO DI FISSAGGIO // FIXING TYPE</b>
---

F • L

G • M

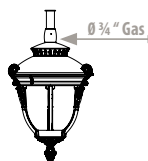

SOSPENSIONE // SUSPENDED

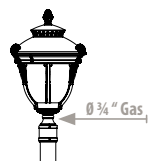

TESTA-PALO // POLE-TOP

<b>DIFFUSORI // DIFFUSERS</b>
-------------------------------



CONICA

L • M



LIRA

F • G

**Su richiesta:**  
policarbonato ghiacciato o trasparente.  
**On request:**  
frosted or transparent polycarbonate.

Disponibile anche nella versione a scarica da 50 a 150 W // Also available in 50 to 150W discharge lamp

Per maggiori informazioni vedi scheda tecnica prodotto // For more information see our product datasheet





**NOTTINGHAM**

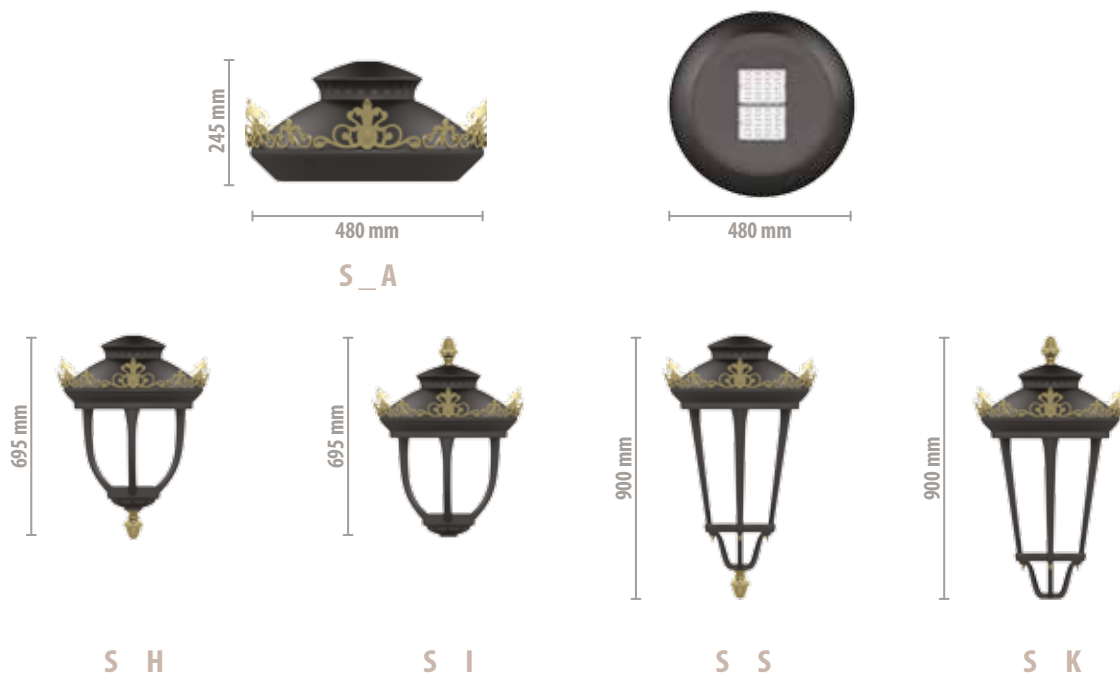

**NOT  
GLASS-FREE**

**Specifiche Tecniche // Technical Features**

<b>MATERIALE:</b>	<b>MATERIAL:</b>	<b>TIMELESS</b>	<b>DIFFUSORI // DIFFUSERS</b>	
pressofusione di alluminio.	die-cast aluminium.	Apparecchio apribile e rigenerabile (componentistica interna sostituibile) senza utilizzo di utensili. <i>Tool-free openable fixture - Replaceable internal components without the need of tools.</i>	ALBA A	CONICA S-K
<b>TEMPERATURA DI COLORE // COLOUR TEMPERATURE</b>		<b>TIPO DI FISSAGGIO // FIXING TYPE</b>		
2200K // 3000K // 4000K // 5700K		A-H-S	A	I-K
<b>DIMMERABILE // DIMMABLE</b>				
<b>SISTEMI OTTICI // OPTICAL SYSTEMS</b>		<b>SOSPENSIONE // SUSPENDED</b>	<b>TESATA DI FUNE // WIRE SYSTEM</b>	<b>TESTA-PALO // POLE-TOP</b>
		ALBA A  CONICA S-K  TONDA A  LIRA H-I		
• TYPE 1 •	• TYPE 2 •	<b>Su richiesta:</b> policarbonato ghiacciato o trasparente. <b>On request:</b> frosted or transparent polycarbonate.		

Disponibile anche nella versione a scarica da 50 a 150 W // Also available in 50 to 150W discharge lamp

Per maggiori informazioni vedi scheda tecnica prodotto // For more information see our product datasheet



**GRANADA**

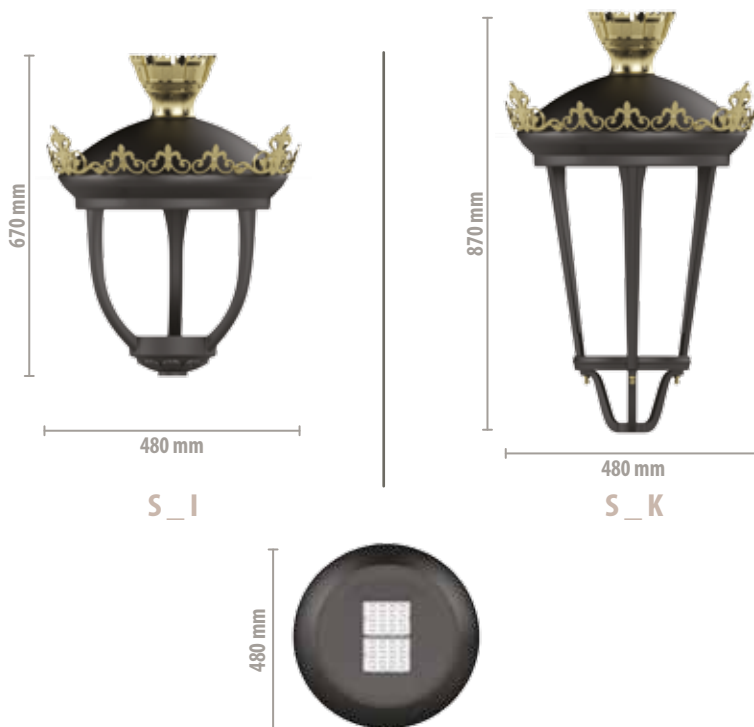

**GRA**  
**GLASS-FREE**

**Specifiche Tecniche // Technical Features**

**MATERIALE:**      **MATERIAL:**

pressofusione  
di alluminio.

die-cast  
aluminium.

 **TIMELESS**

Apparecchio apribile e rigenerabile (componentistica interna sostituibile) senza utilizzo di utensili.  
*Tool-free openable fixture - Replaceable internal components without the need of tools.*

**DIFFUSORI // DIFFUSERS**



**CONICA**

**K**



**LIRA**

**I**

**TEMPERATURA DI COLORE // COLOUR TEMPERATURE**

2200K // 3000K // 4000K // 5700K

**TIPO DI FISSAGGIO // FIXING TYPE**

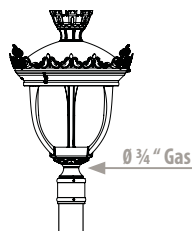

**TESTA-PALO // POLE-TOP**

**SISTEMI OTTICI // OPTICAL SYSTEMS**



• TYPE 1 •

• TYPE 2 •

• TYPE 3 •

• TYPE 5 •

**Su richiesta:**  
policarbonato ghiacciato o trasparente.  
**On request:**  
frosted or transparent polycarbonate.

Disponibile anche nella versione a scarica da 50 a 150 W // Also available in 50 to 150W discharge lamp

Per maggiori informazioni vedi scheda tecnica prodotto // For more information see our product datasheet





**LQ093**

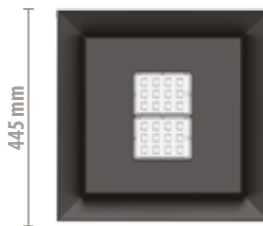
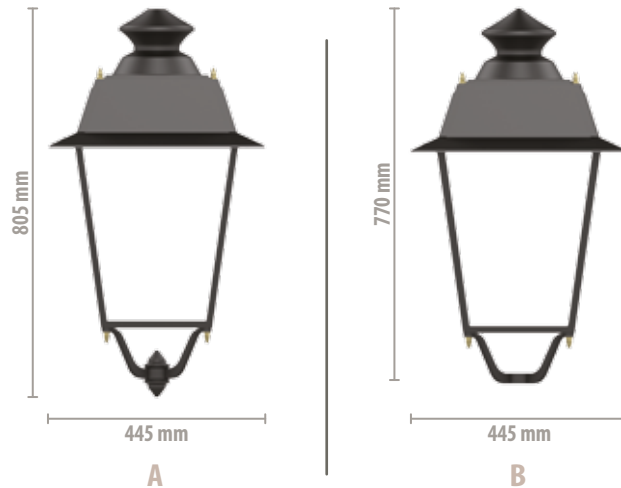

**L93  
GLASS-FREE**

**Specifiche Tecniche // Technical Features**

**MATERIALE:**      **MATERIAL:**

pressofusione  
di alluminio.

die-cast  
aluminium.

**TIMELESS**

Apparecchio apribile e rigenerabile (componentistica interna sostituibile) senza utilizzo di utensili.  
*Tool-free openable fixture - Replaceable internal components without the need of tools.*

**DIFFUSORI // DIFFUSERS**



**QUADRATA  
A - B**

**TEMPERATURA DI COLORE // COLOUR TEMPERATURE**

2200K // 3000K // 4000K // 5700K

**TIPO DI FISSAGGIO // FIXING TYPE**

**A**

**B**

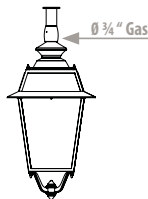

**SOSPENSIONE //  
SUSPENDED**

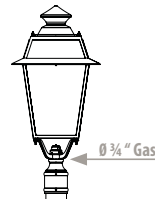

**TESTA-PALO //  
POLE-TOP**

**DIMMERABILE // DIMMABLE**

**SISTEMI OTTICI // OPTICAL SYSTEMS**



• TYPE 1 •      • TYPE 2 •      • TYPE 3 •      • TYPE 5 •

**Su richiesta:**  
policarbonato ghiacciato o trasparente.  
**On request:**  
frosted or transparent polycarbonate.

Disponibile anche nella versione a scarica da 50 a 150 W // Also available in 50 to 150W discharge lamp

Per maggiori informazioni vedi scheda tecnica prodotto // For more information see our product datasheet



**LQ094**







A

B

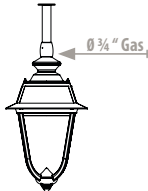
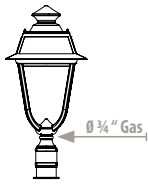
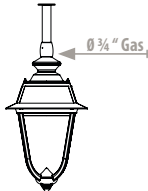
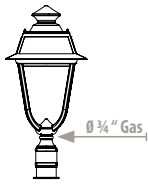
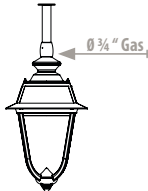
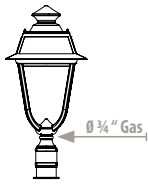

**L94  
GLASS-FREE**

**Specifiche Tecniche // Technical Features**

<b>MATERIALE:</b>	<b>MATERIAL:</b>	 <b>TIMELESS</b> Apparecchio apribile e rigenerabile (componentistica interna sostituibile) senza utilizzo di utensili. <i>Tool-free openable fixture - Replaceable internal components without the need of tools.</i>						
pressofusione di alluminio.	die-cast aluminium.							
<b>TEMPERATURA DI COLORE // COLOUR TEMPERATURE</b>		<b>TIPO DI FISSAGGIO // FIXING TYPE</b>						
2200K // 3000K // 4000K // 5700K		<table border="1"> <thead> <tr> <th data-bbox="817 1497 1046 1538">A</th> <th data-bbox="1046 1497 1286 1538">B</th> </tr> </thead> <tbody> <tr> <td data-bbox="817 1538 1046 1755">  </td> <td data-bbox="1046 1538 1286 1755">  </td> </tr> <tr> <td data-bbox="817 1755 1046 1806"><b>SOSPENSIONE // SUSPENDED</b></td> <td data-bbox="1046 1755 1286 1806"><b>TESTA-PALO // POLE-TOP</b></td> </tr> </tbody> </table>	A	B			<b>SOSPENSIONE // SUSPENDED</b>	<b>TESTA-PALO // POLE-TOP</b>
A	B							
								
<b>SOSPENSIONE // SUSPENDED</b>	<b>TESTA-PALO // POLE-TOP</b>							
<b>DIMMERABILE // DIMMABLE</b>								
<b>SISTEMI OTTICI // OPTICAL SYSTEMS</b>								
								
								
• TYPE 1 •	• TYPE 2 •							
• TYPE 3 •	• TYPE 5 •							

Disponibile anche nella versione a scarica da 50 a 150 W // Also available in 50 to 150W discharge lamp

Per maggiori informazioni vedi scheda tecnica prodotto // For more information see our product datasheet





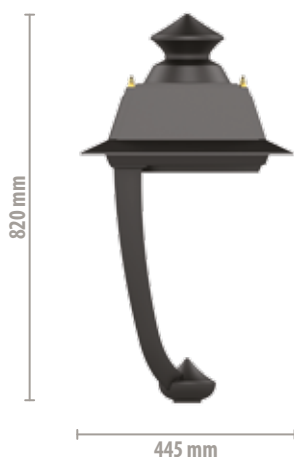

**LQ091**

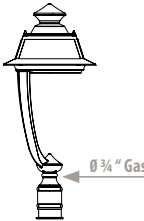

**L91  
GLASS-FREE**

**Specifiche Tecniche // Technical Features**

<b>MATERIALE:</b>	<b>MATERIAL:</b>	<b>TIMELESS</b>
pressofusione di alluminio.	die-cast aluminium.	Apparecchio apribile e rigenerabile (componentistica interna sostituibile) senza utilizzo di utensili. <i>Tool-free openable fixture - Replaceable internal components without the need of tools.</i>
<b>TEMPERATURA DI COLORE // COLOUR TEMPERATURE</b>		<b>TIPO DI FISSAGGIO // FIXING TYPE</b>
2200K // 3000K // 4000K // 5700K		
<b>DIMMERABILE // DIMMABLE</b>		
<b>SISTEMI OTTICI // OPTICAL SYSTEMS</b>		
		<b>TESTA-PALO // POLE-TOP</b>
		
• TYPE 1 •	• TYPE 2 •	
• TYPE 3 •	• TYPE 5 •	

Disponibile anche nella versione a scarica da 50 a 150 W // Also available in 50 to 150W discharge lamp

Per maggiori informazioni vedi scheda tecnica prodotto // For more information see our product datasheet





**CROTONE**

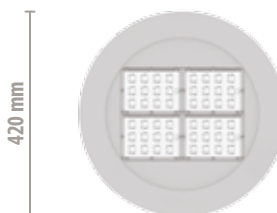

**CRO  
GLASS-FREE**

**Specifiche Tecniche // Technical Features**

<b>MATERIALE:</b>	<b>MATERIAL:</b>	<b>TIMELESS</b>
pressofusione di alluminio, lamiera di alluminio.	die-cast aluminium, aluminium sheet.	Apparecchio apribile e rigenerabile (componentistica interna sostituibile) senza utilizzo di utensili. <i>Tool-free openable fixture - Replaceable internal components without the need of tools.</i>
<b>TEMPERATURA DI COLORE // COLOUR TEMPERATURE</b>		<b>TIPO DI FISSAGGIO // FIXING TYPE</b>
2200K // 3000K // 4000K // 5700K		
<b>DIMMERABILE // DIMMABLE</b>		<p>SOSPENSIONE // SUSPENDED</p> <p>TESATA DI FUNE // WIRE SYSTEM</p>
<b>SISTEMI OTTICI // OPTICAL SYSTEMS</b>		
<p>· TYPE 1 ·   · TYPE 2 ·   · TYPE 3 ·   · TYPE 5 ·</p>		

Disponibile anche nella versione a scarica da 50 a 150 W // Also available in 50 to 150W discharge lamp

Per maggiori informazioni vedi scheda tecnica prodotto // For more information see our product datasheet



**COSENZA**

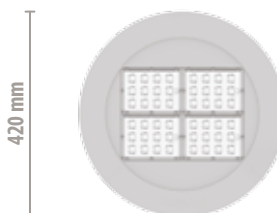

**COS  
GLASS-FREE**

**Specifiche Tecniche // Technical Features**

<b>MATERIALE:</b>	<b>MATERIAL:</b>	<b>TIMELESS</b>
pressofusione di alluminio, lamiera di alluminio.	die-cast aluminium, aluminium sheet.	Apparecchio apribile e rigenerabile (componentistica interna sostituibile) senza utilizzo di utensili. <i>Tool-free openable fixture - Replaceable internal components without the need of tools.</i>
<b>TEMPERATURA DI COLORE // COLOUR TEMPERATURE</b>		<b>TIPO DI FISSAGGIO // FIXING TYPE</b>
2200K // 3000K // 4000K // 5700K		
<b>DIMMERABILE // DIMMABLE</b>		<p data-bbox="868 1755 991 1806"><b>SOSPENSIONE // SUSPENDED</b></p> <p data-bbox="1098 1755 1235 1806"><b>TESATA DI FUNE // WIRE SYSTEM</b></p>
<b>SISTEMI OTTICI // OPTICAL SYSTEMS</b>		
• TYPE 1 •	• TYPE 2 •	
• TYPE 3 •	• TYPE 5 •	

Disponibile anche nella versione a scarica da 50 a 150 W // Also available in 50 to 150W discharge lamp

Per maggiori informazioni vedi scheda tecnica prodotto // For more information see our product datasheet



**MINA**

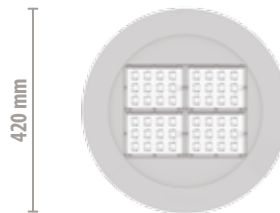

**MIN  
GLASS-FREE**

**Specifiche Tecniche // Technical Features**

<b>MATERIALE:</b>	<b>MATERIAL:</b>	<b>TIMELESS</b>	
pressofusione di alluminio.	die-cast aluminium.	Apparecchio apribile e rigenerabile (componentistica interna sostituibile) senza utilizzo di utensili. <i>Tool-free openable fixture - Replaceable internal components without the need of tools.</i>	
<b>TEMPERATURA DI COLORE // COLOUR TEMPERATURE</b>		<b>TIPO DI FISSAGGIO // FIXING TYPE</b>	
2200K // 3000K // 4000K // 5700K			
<b>DIMMERABILE // DIMMABLE</b>		<p data-bbox="868 1755 991 1804"><b>SOSPENSIONE // SUSPENDED</b></p> <p data-bbox="1098 1755 1236 1804"><b>TESATA DI FUNE // WIRE SYSTEM</b></p>	
<b>SISTEMI OTTICI // OPTICAL SYSTEMS</b>			
<p data-bbox="331 1766 395 1796">• TYPE 1 •</p>	<p data-bbox="448 1766 512 1796">• TYPE 2 •</p>	<p data-bbox="560 1766 624 1796">• TYPE 3 •</p>	<p data-bbox="671 1766 735 1796">• TYPE 5 •</p>

Disponibile anche nella versione a scarica da 50 a 150 W // Also available in 50 to 150W discharge lamp

Per maggiori informazioni vedi scheda tecnica prodotto // For more information see our product datasheet





**Illuminazione artistica //**  
*classic lighting*

**PALI // poles**

414	<b>FE POLE</b>
416	<b>IDRO POLE</b>
418	<b>CRIS POLE</b>
422	<b>AMI POLE</b>
424	<b>YTER POLE</b>
426	<b>SARA POLE</b>
430	<b>CIRRO POLE</b>
432	<b>ALOSA POLE</b>
434	<b>SIRIO POLE</b>
438	<b>ACI POLE</b>
440	<b>ORIONE POLE</b>
444	<b>RIO POLE</b>
446	<b>BERTY POLE</b>
448	<b>CQC POLE</b>
452	<b>VASTO POLE</b>
454	<b>OTIS POLE</b>
456	<b>QU POLE</b>
460	<b>AVELLINO POLE</b>
462	<b>CELIO POLE</b>
464	<b>ROMA POLE</b>

**SISTEMI CIMA-PALO // pole-top systems**

468	<b>ACI POLE-TOP SYSTEM</b>
470	<b>BK POLE-TOP SYSTEM</b>

**MENSOLE A PALO // pole arms**

474	<b>VELA POLE ARM</b>
476	<b>ORIONE, SIRIO POLE ARMS</b>
480	<b>TIRO POLE ARM</b>
482	<b>COLIBRÌ POLE ARM</b>
486	<b>MILVA POLE ARM</b>
488	<b>FLIPPY POLE ARM</b>
490	<b>TENCO POLE ARM</b>
492	<b>TRALI POLE ARM</b>
494	<b>OLBIA POLE ARM</b>
498	<b>LP, VAL, IMC POLE ARMS</b>

**MENSOLE A MURO // wall brackets**

502	<b>SIRIO, VELA, TIRO WALL BRACKETS</b>
504	<b>MILVA, FLIPPY, TENCO WALL BRACKETS</b>
506	<b>FE WALL BRACKET</b>
510	<b>LP, VAL, IMC WALL BRACKETS</b>

# ghisa - acciaio

## *cast-iron and steel*

Ghisa-acciaio offre un'ampia gamma di soluzioni di illuminazione di arredo, in cui la semplicità del palo cilindrico rastremato è arricchita dal design elegante della base in ghisa, delle mensole e dei pastorali.

*Cast-iron and steel offers a vast large range of lighting and urban furniture solutions in which the simplicity of the cylindrical tapered steel pole is enriched by the elegant design of the cast iron base and of the poles arms.*



**FE POLE**

“Fe” è la serie di pali cilindrici rastremati che per la sua semplicità si presta ad ogni applicazione di illuminazione.

“Fe” is a series of cylindrical tapered poles, well suited for any lighting application thanks to their simplicity.

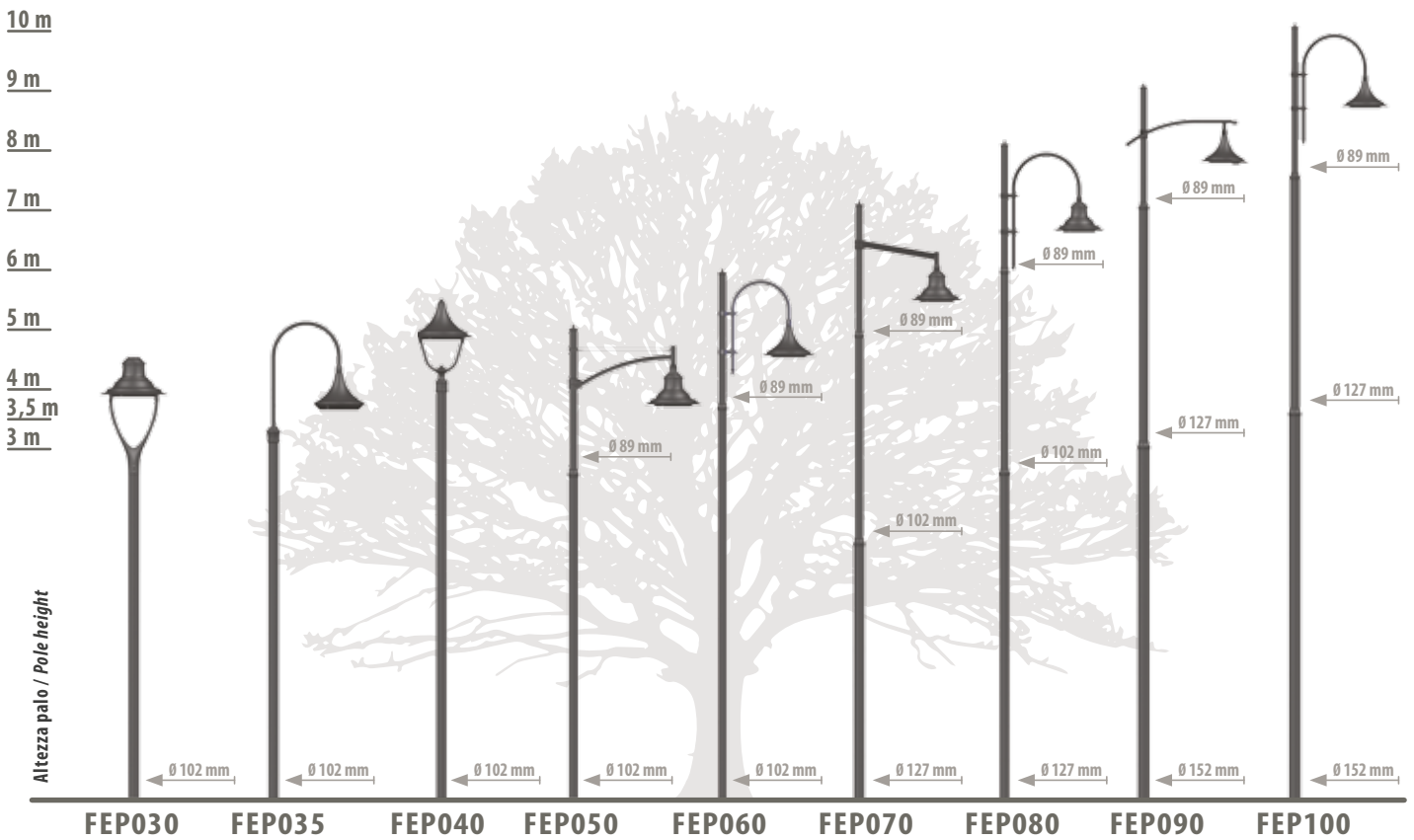

**Versioni Disponibili // Available Versions**

Tipo di fissaggio: flangia o fondazione / Fixing type: flange or foundation

Le composizioni proposte sono puramente indicative: mensole, pastorali e corpi illuminanti a scelta / The compositions presented are purely indicative: light fixtures and arms of your choice

**Punte Disponibili // Available Tops**

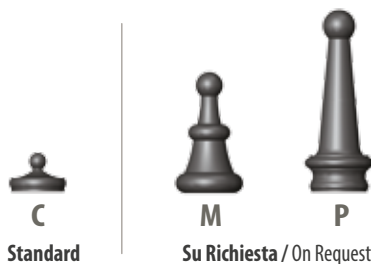



**IDRO POLE**

“Idro” è una serie di pali essenziali, in cui la prevalenza della direzionalità verticale è stemperata dalla semplicità della base tronco conica.

“Idro” is a series of essential poles. In this series, the verticality is softened by the simple conical base.

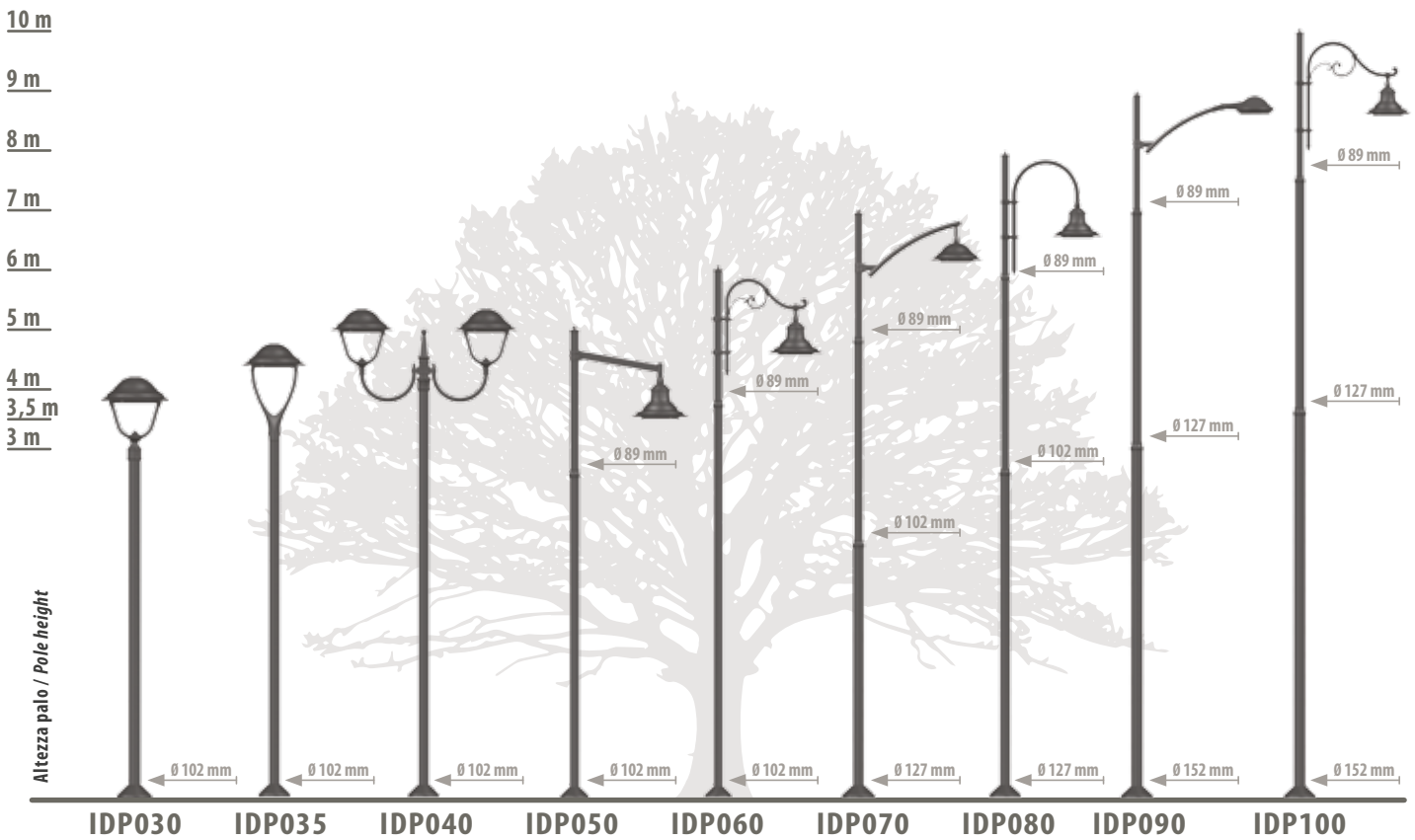

**Versioni Disponibili // Available Versions**

Tipo di fissaggio: flangia o fondazione / Fixing type: flange or foundation

Le composizioni proposte sono puramente indicative: mensole, pastorali e corpi illuminanti a scelta /

The compositions presented are purely indicative: light fixtures and arms of your choice

**Punte Disponibili // Available Tops**

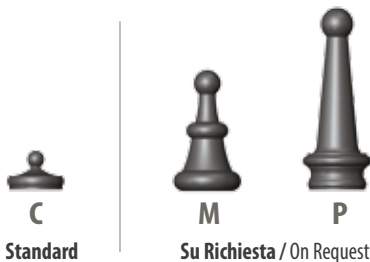

**Basi Palo // Pole Bases**

<b>IDR010</b>	<b>IDP030 / IDP060</b> ø 300 mm - h 120 mm
<b>IDR012</b>	<b>IDP070 / IDP080</b> ø 390 mm - h 156 mm
<b>IDR015</b>	<b>IDP090 / IDP100</b> ø 416 mm - h 156 mm





## CRIS POLE

La serie di pali "Cris", caratteristica per le modanature di gusto corinzio della piccola base in ghisa, è particolarmente adatta per soluzioni testa-palo.

*"Cris" is a series of poles characterised by the distinctive Corinthian style moulding of the small cast iron base. They are particularly suitable for pole-head solutions.*

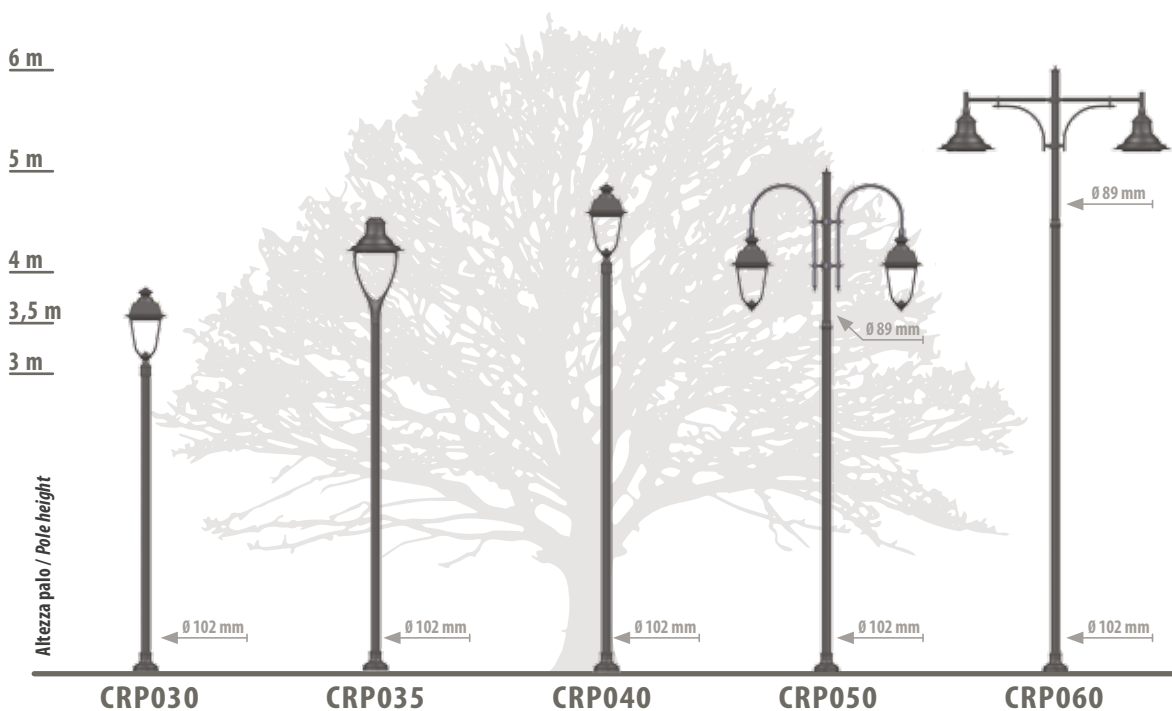

### Versioni Disponibili // Available Versions

Tipo di fissaggio: flangia o fondazione / Fixing type: flange or foundation

Le composizioni proposte sono puramente indicative: mensole, pastorali e corpi illuminanti a scelta /  
The compositions presented are purely indicative: light fixtures and arms of your choice

### Punte Disponibili // Available Tops

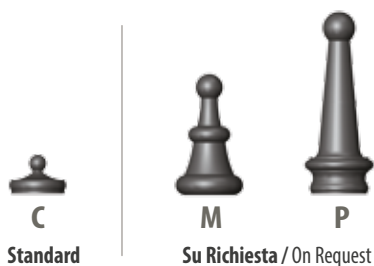

### Basi Palo // Pole Bases



**Illuminazione artistica // classic lighting**









**AMI POLE**

“Ami” è una serie di pali che si distingue per l’eleganza delle forme dolcemente curve della base in ghisa.

“Ami” is a series of poles, which set themselves apart for the elegance of the gently curved shapes of the cast iron base.

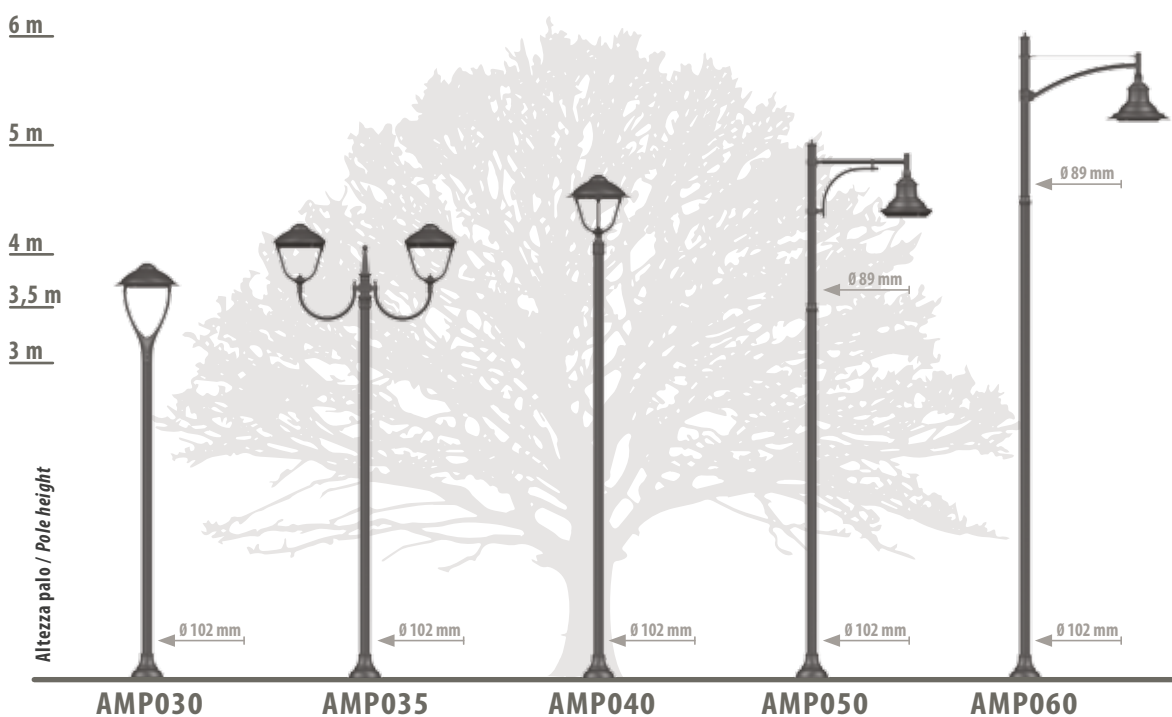

**Versioni Disponibili // Available Versions**

Tipo di fissaggio: flangia o fondazione / Fixing type: flange or foundation

Le composizioni proposte sono puramente indicative: mensole, pastorali e corpi illuminanti a scelta /  
The compositions presented are purely indicative: light fixtures and arms of your choice

**Punte Disponibili // Available Tops**

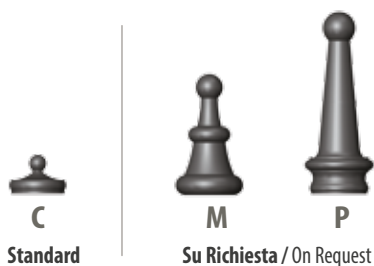

**Basi Palo // Pole Bases**







## YTER POLE

La curvatura della base, che accompagna il palo nel suo stacco da terra, rende la serie "Yter" una soluzione versatile, in grado di adattarsi ad ogni contesto.

*The curvature of the base launches the "Yter" pole upwards, making it able to fit any urban environment.*



### Versioni Disponibili // Available Versions

Tipo di fissaggio: flangia o fondazione / Fixing type: flange or foundation

Le composizioni proposte sono puramente indicative: mensole, pastorali e corpi illuminanti a scelta /

The compositions presented are purely indicative: light fixtures and arms of your choice

### Punte Disponibili // Available Tops

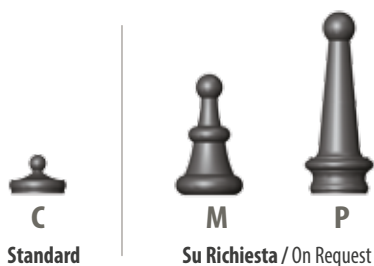

### Basi Palo // Pole Bases



YTER10 YTP030 / YTP060  
Ø 300 mm - h 360 mm

YTER12 YTP070 / YTP080  
Ø 380 mm - h 450 mm



## SARA POLE

I pali della serie "Sara" si distinguono per la delicatezza della base ondulata che, con i suoi giochi di luce ed ombra, dona grazia e leggerezza alla composizione.

*"Sara" is a series of poles which set themselves apart for the delicacy of the undulated base. The interplay of light and shadow gives the composition grace and lightness.*

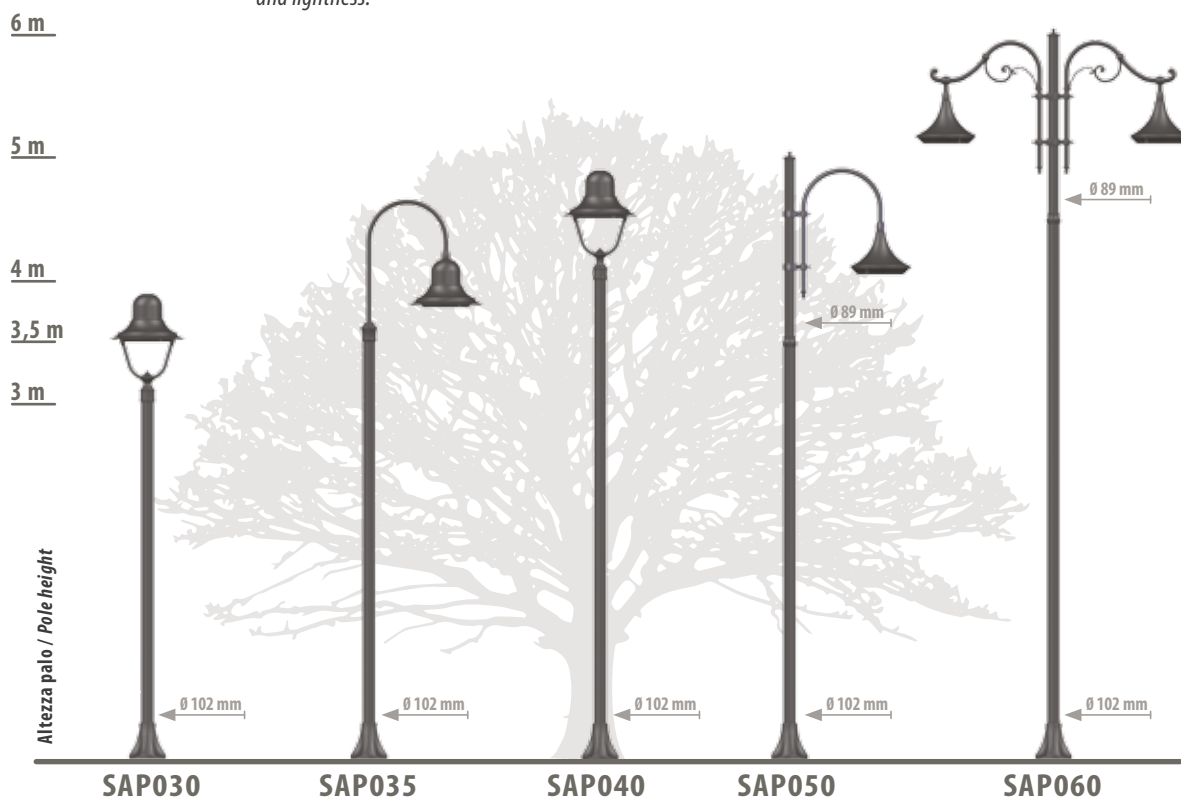

### Versioni Disponibili // Available Versions

Tipo di fissaggio: flangia o fondazione / Fixing type: flange or foundation

Le composizioni proposte sono puramente indicative: mensole, pastorali e corpi illuminanti a scelta /  
The compositions presented are purely indicative: light fixtures and arms of your choice

### Punte Disponibili // Available Tops

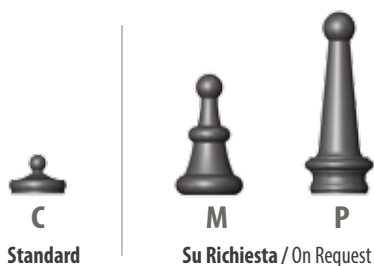

### Basi Palo // Pole Bases



**SARA10** SAP030 / SAP060  
Ø 300 mm - h 300 mm

**illuminazione artistica // classic lighting**









## CIRRO POLE

La fantasiosa sagoma della base distingue la serie di pali "Cirro", rendendoli capaci di caratterizzare il contesto in cui vengono inseriti.

*The imaginative shape of the base sets the series of "Cirro" poles apart, making them able allowing them to characterize the context into which they are installed.*

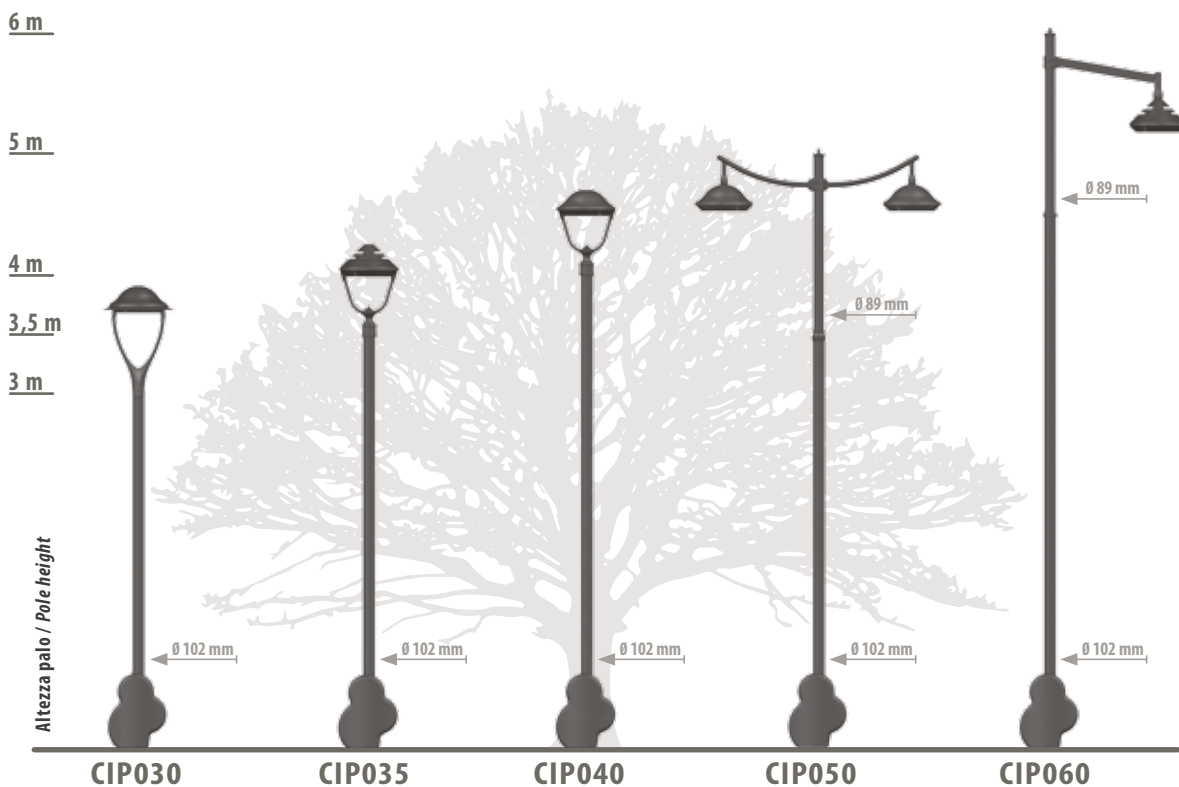

### Versioni Disponibili // Available Versions

Tipo di fissaggio: fondazione / Fixing type: foundation

Le composizioni proposte sono puramente indicative: mensole, pastorali e corpi illuminanti a scelta /  
The compositions presented are purely indicative: light fixtures and arms of your choice

### Punte Disponibili // Available Tops

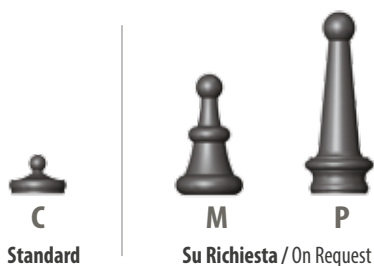

### Basi Palo // Pole Bases





**ALOSA POLE**

“Alosa” è una serie di pali eleganti, nobilitati dalla curvatura della base leggermente asimmetrica.

“Alosa” is a series of elegant poles, elevated by the curved and slightly asymmetrical base.

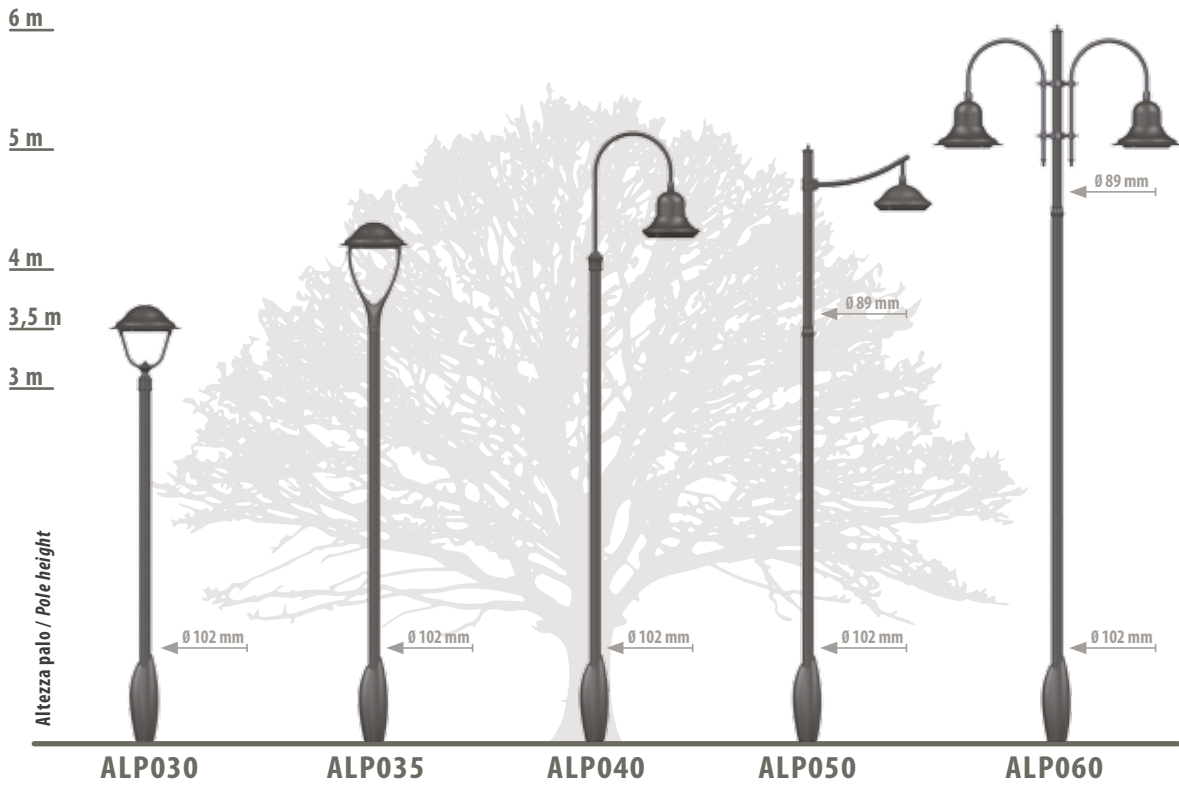

**Versioni Disponibili // Available Versions**

Tipo di fissaggio: fondazione / Fixing type: foundation

Le composizioni proposte sono puramente indicative: mensole, pastorali e corpi illuminanti a scelta /  
The compositions presented are purely indicative: light fixtures and arms of your choice

**Punte Disponibili // Available Tops**

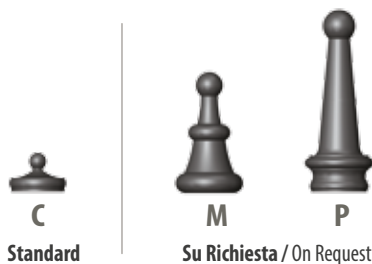

**Basi Palo // Pole Bases**



**ALOSA10 ALP030 / ALP060**  
a 155 mm - c 160 mm  
b 245 mm - d 197 mm  
h 730 mm



## SIRIO POLE

Elegante e di forte impatto visivo, "Sirio" è una serie di pali disegnati per caratterizzare il contesto in cui vengono inseriti.

*Elegant and with a strong visual impact, "Sirio" is a series of poles designed to characterize the context into which they are installed.*

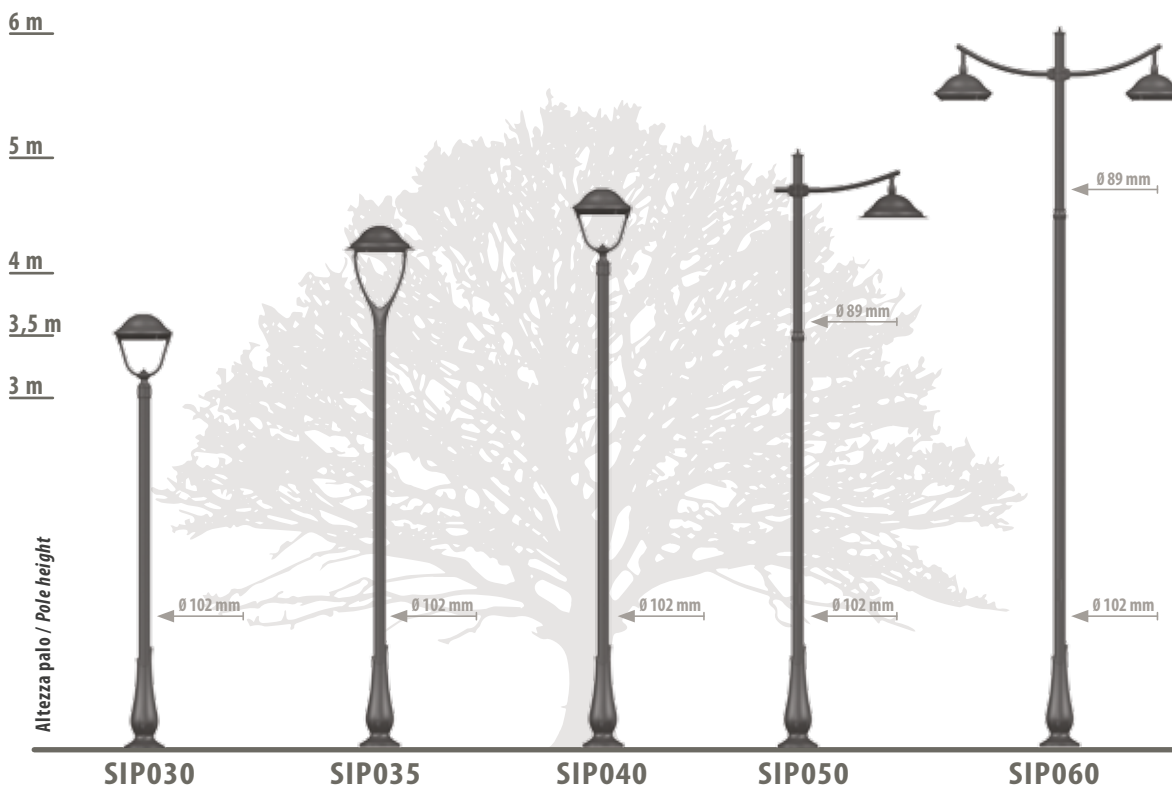

### Versioni Disponibili // Available Versions

Tipo di fissaggio: flangia o fondazione / Fixing type: flange or foundation

Le composizioni proposte sono puramente indicative: mensole, pastorali e corpi illuminanti a scelta /

The compositions presented are purely indicative: light fixtures and arms of your choice

### Punte Disponibili // Available Tops

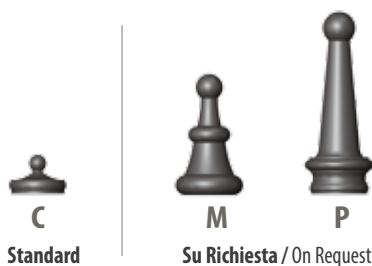

### Basi Palo // Pole Bases



**SIRIO10** SIP030 / SIP060  
Ø 340 mm - h 850 mm



**Illuminazione artistica // classic lighting**









## ACI POLE

“Aci” è una serie di pali dall'estetica intramontabile: la base rastremata e slanciata conferisce al palo un aspetto elegante e moderno.

“Aci” is a series of poles with timeless aesthetics: the tapered and sleek base gives the pole a modern and elegant look.

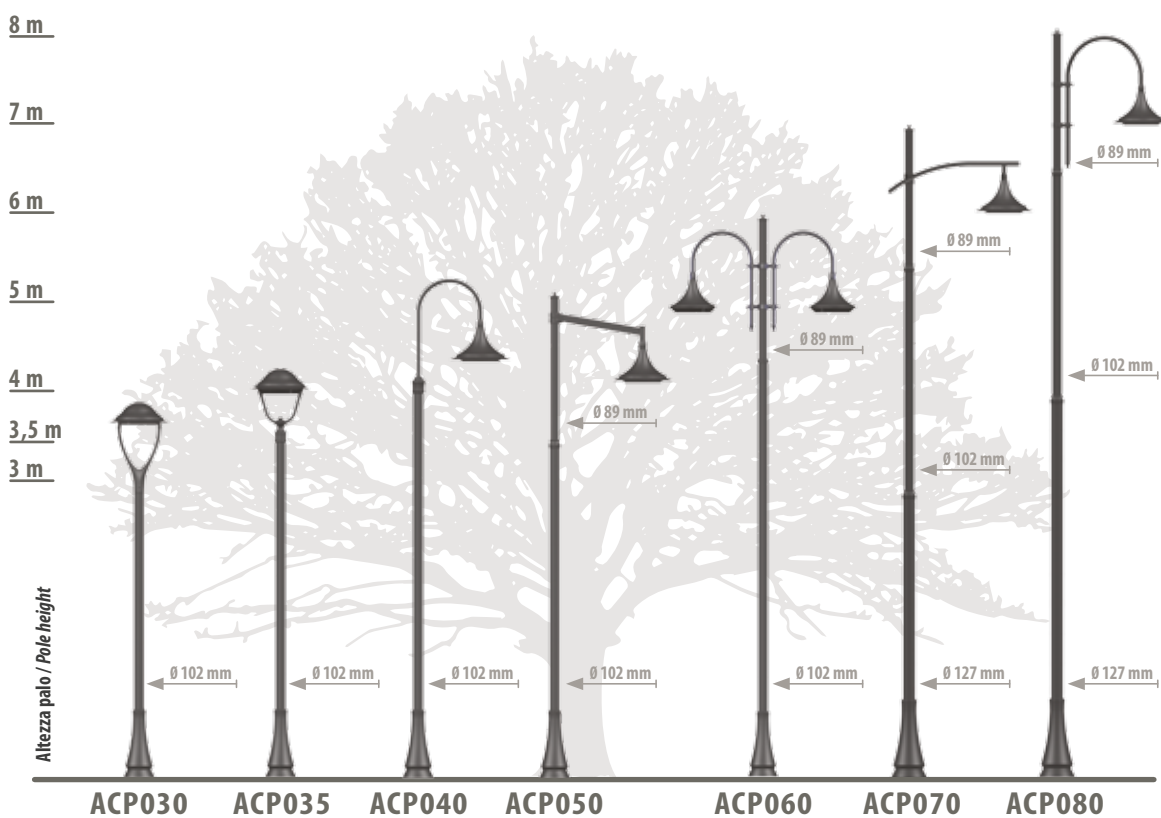

### Versioni Disponibili // Available Versions

Tipo di fissaggio: flangia o fondazione / Fixing type: flange or foundation

Le composizioni proposte sono puramente indicative: mensole, pastorali e corpi illuminanti a scelta /

The compositions presented are purely indicative: light fixtures and arms of your choice

### Punte Disponibili // Available Tops

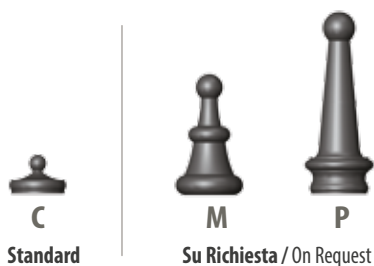

### Basi Palo // Pole Bases



**ACI10** ACP030 / ACP060  
Ø 320 mm - h 690 mm

**ACI12** ACP070 / ACP080  
Ø 380 mm - h 840 mm



**ORIONE POLE**

Il profilo eccentrico ed originale della base caratterizza la serie di pali "Orione" e li rende elementi distintivi del panorama urbano.

*The eccentric and original profile of the base characterises the series of "Orione" poles and makes them distinctive elements of the urban panorama.*

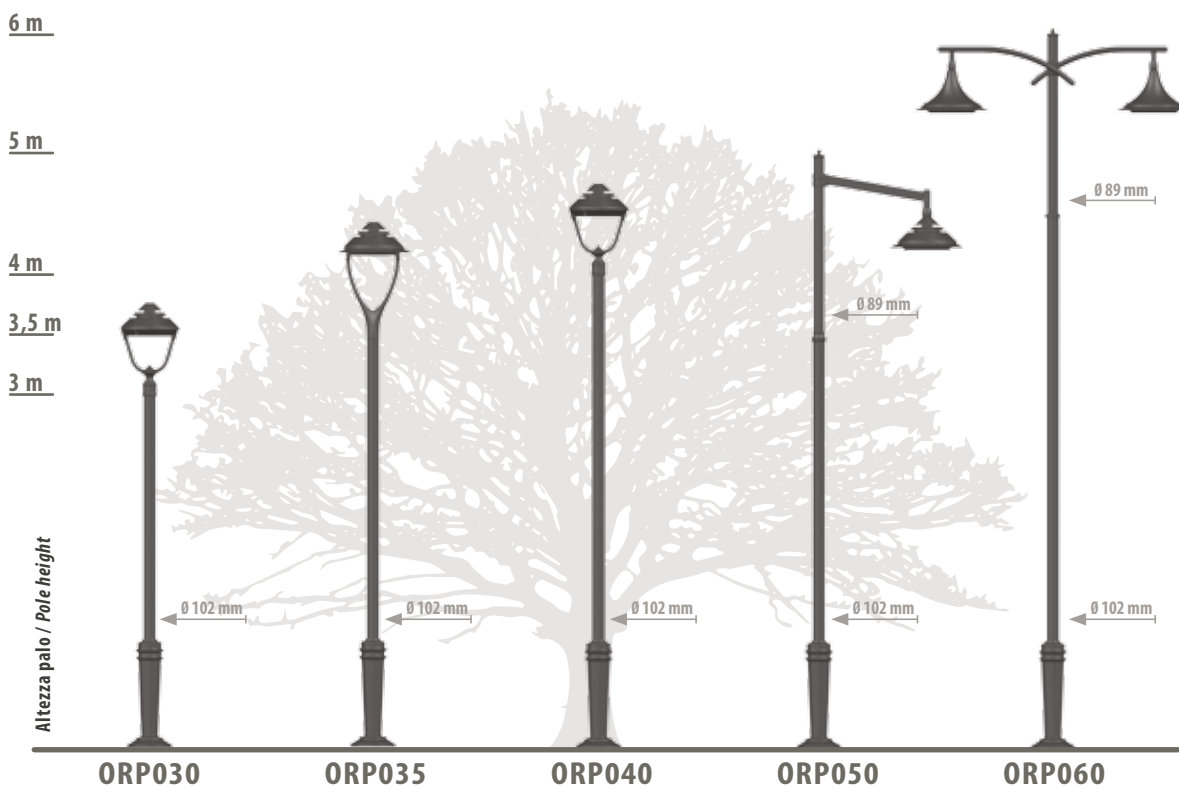

**Versioni Disponibili // Available Versions**

Tipo di fissaggio: flangia o fondazione / Fixing type: flange or foundation

Le composizioni proposte sono puramente indicative: mensole, pastorali e corpi illuminanti a scelta /  
The compositions presented are purely indicative: light fixtures and arms of your choice

**Punte Disponibili // Available Tops**

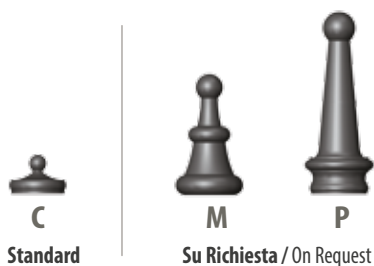

**Basi Palo // Pole Bases**



**ORIONE10** ORP030 / ORP060  
Ø 370 mm - h 890 mm



**illuminazione artistica // classic lighting**







## RIO POLE

La serie di pali "Rio" è contraddistinta dalle decorazioni floreali della base.

*The series of "Rio" poles sets itself apart by the floral decorations of the base, which mark the attachment of the pole to the ground.*

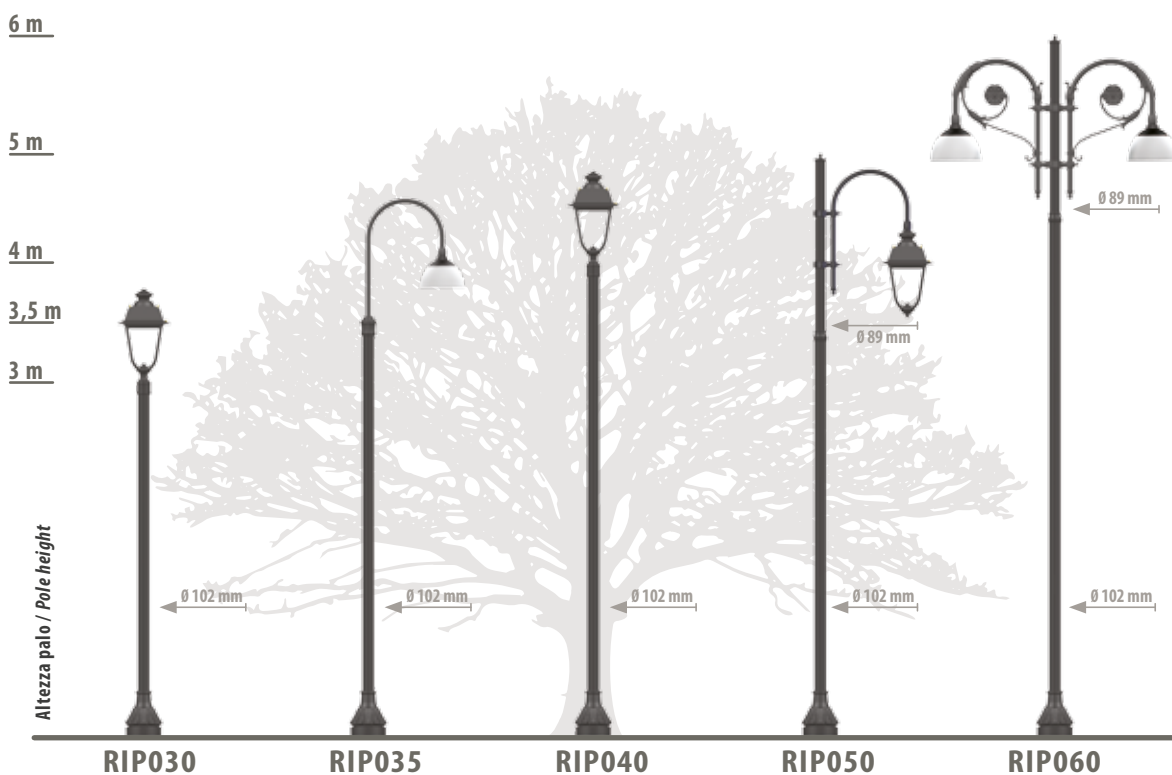

### Versioni Disponibili // Available Versions

Tipo di fissaggio: flangia o fondazione / Fixing type: flange or foundation

Le composizioni proposte sono puramente indicative: mensole, pastorali e corpi illuminanti a scelta /

The compositions presented are purely indicative: light fixtures and arms of your choice

### Punte Disponibili // Available Tops

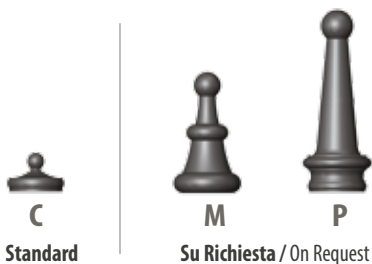

### Basi Palo // Pole Bases



**RIO10** RIP030 / RIP060  
Ø 300 mm - h 390 mm





## BERTY POLE

"Berty" è una serie dal design classico. La semplicità della base rende i pali adattabili ad ogni contesto.

"Berty" is a classic design series. The simplicity of the base makes the poles easy to match with brackets and lighting fixtures.

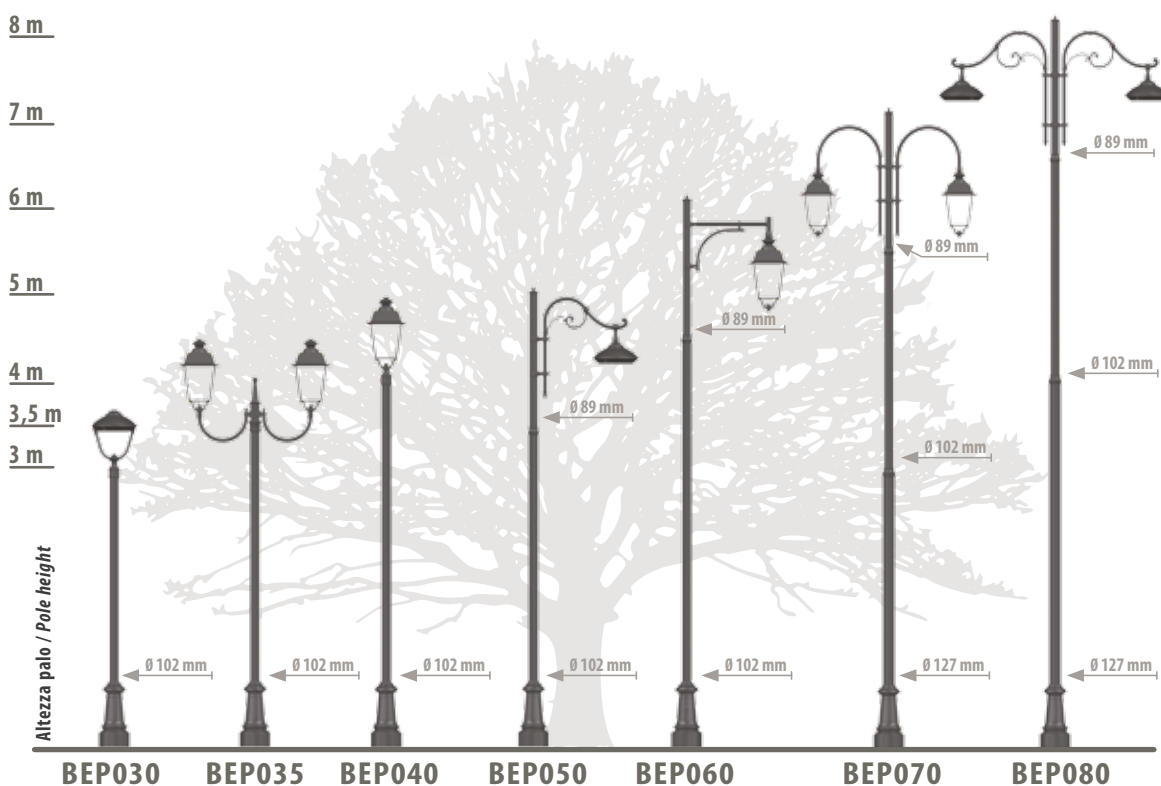

### Versioni Disponibili // Available Versions

Tipo di fissaggio: flangia o fondazione / Fixing type: flange or foundation

Le composizioni proposte sono puramente indicative: mensole, pastorali e corpi illuminanti a scelta /

The compositions presented are purely indicative: light fixtures and arms of your choice

### Punte Disponibili // Available Tops

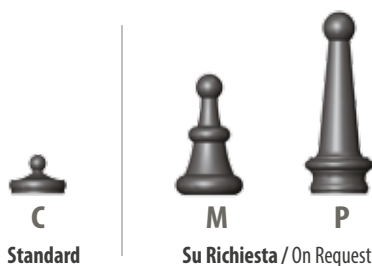

### Basi Palo // Pole Bases



**BERTY10 BEP030 / BEP080**  
Ø 330 mm - h 705 mm





## CQC POLE

La serie "Cqc" si distingue per il carattere ornamentale della base, in grado di infondere eleganza a parchi, giardini o aree urbane di pregio.

*The "Cqc" series sets itself apart for the ornamental character of the base, able to instil elegance in parks, gardens or prestigious urban areas.*

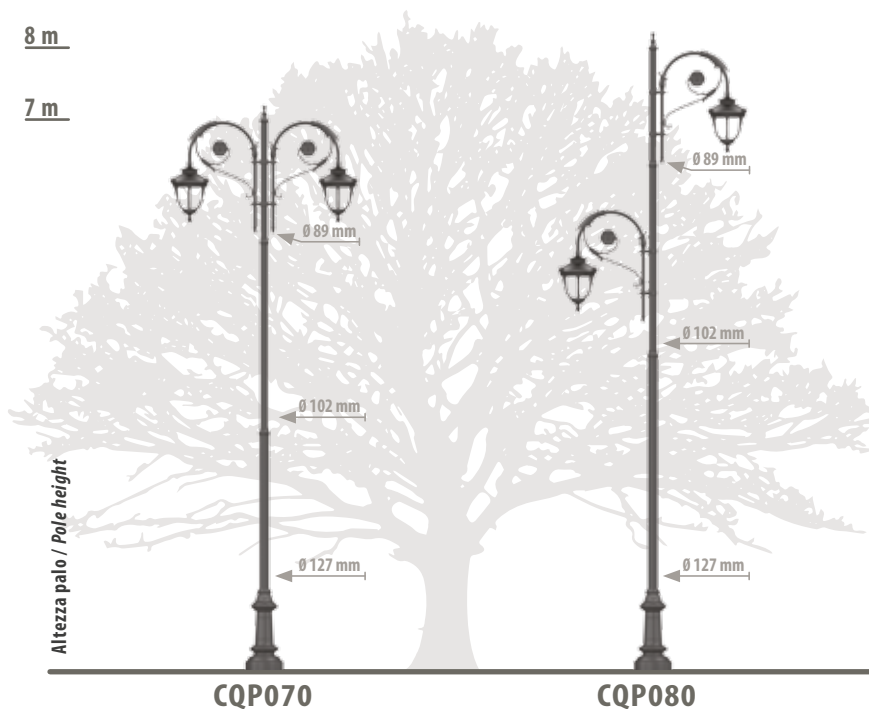

**CQP070**

**CQP080**

### Versioni Disponibili // Available Versions

Tipo di fissaggio: flangia o fondazione / Fixing type: flange or foundation

Le composizioni proposte sono puramente indicative: mensole, pastorali e corpi illuminanti a scelta /  
The compositions presented are purely indicative: light fixtures and arms of your choice

### Punte Disponibili // Available Tops



**M**  
Standard



**C**  
Su Richiesta / On Request



**P**

### Basi Palo // Pole Bases



**CQC12** CQP070 / CQP080

Ø 480 mm - h 1.027 mm

**illuminazione artistica // classic lighting**









## VASTO POLE

I pali della serie "Vasto" si distinguono per la semplicità della base, che li rende particolarmente adatti ad essere abbinati a mensole e corpi illuminanti in stile classico.

*The poles of the "Vasto" series set themselves apart for the simplicity of the base which makes them particularly suited to being matched to classic style arms and lighting fixtures.*

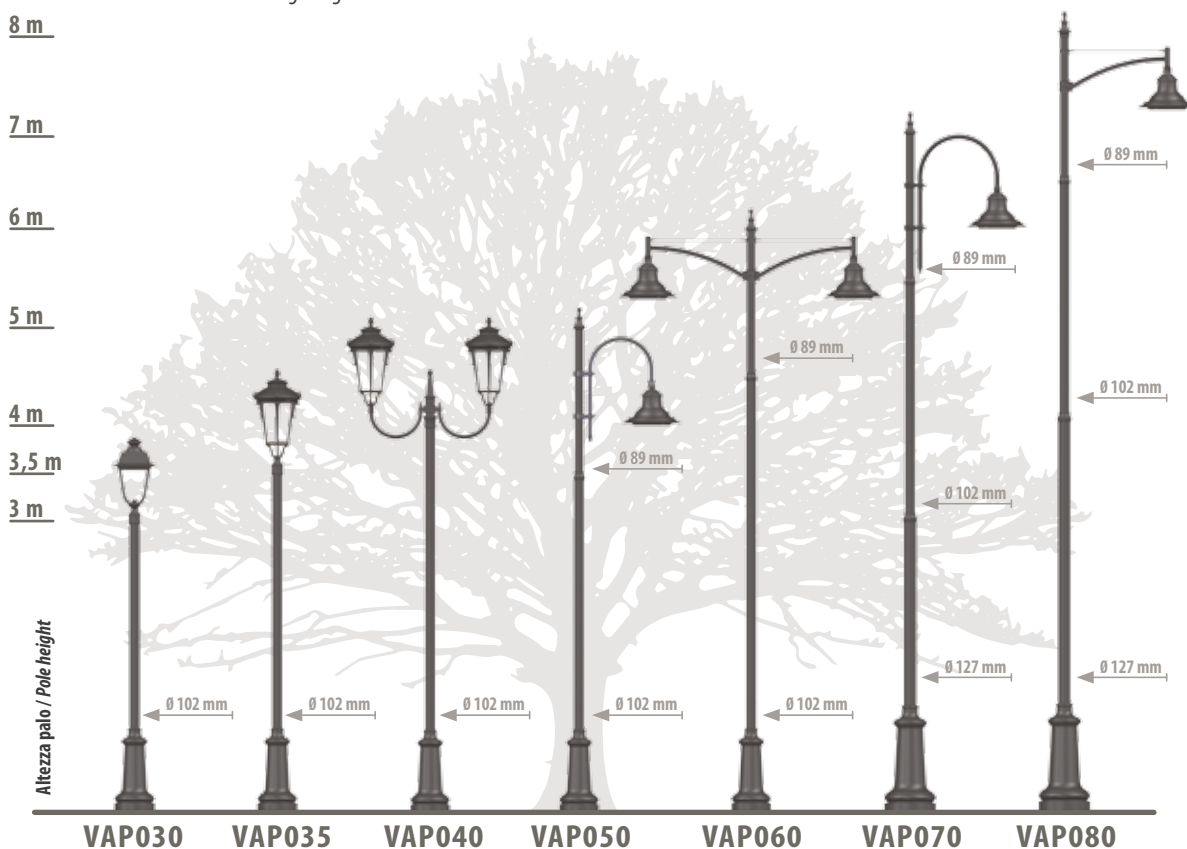

### Versioni Disponibili // Available Versions

Tipo di fissaggio: flangia o fondazione / Fixing type: flange or foundation  
 Le composizioni proposte sono puramente indicative: mensole, pastorali e corpi illuminanti a scelta /  
 The compositions presented are purely indicative: light fixtures and arms of your choice

### Punte Disponibili // Available Tops



### Basi Palo // Pole Bases



**VASTO10** VAP030 / VAP060  
 ø 400 mm - h 840 mm

**VASTO12** VAP070 / VAP080  
 ø 520 mm - h 1.100 mm





**OTIS POLE**

La base affusolata e sottile delle serie di pali "Otis" li rende versatili ed essenziali, adatti a contesti urbani storici o contemporanei.

*The thin and slender base of the "Otis" series of poles makes them versatile and essential, suited to both contemporary and classic urban settings.*

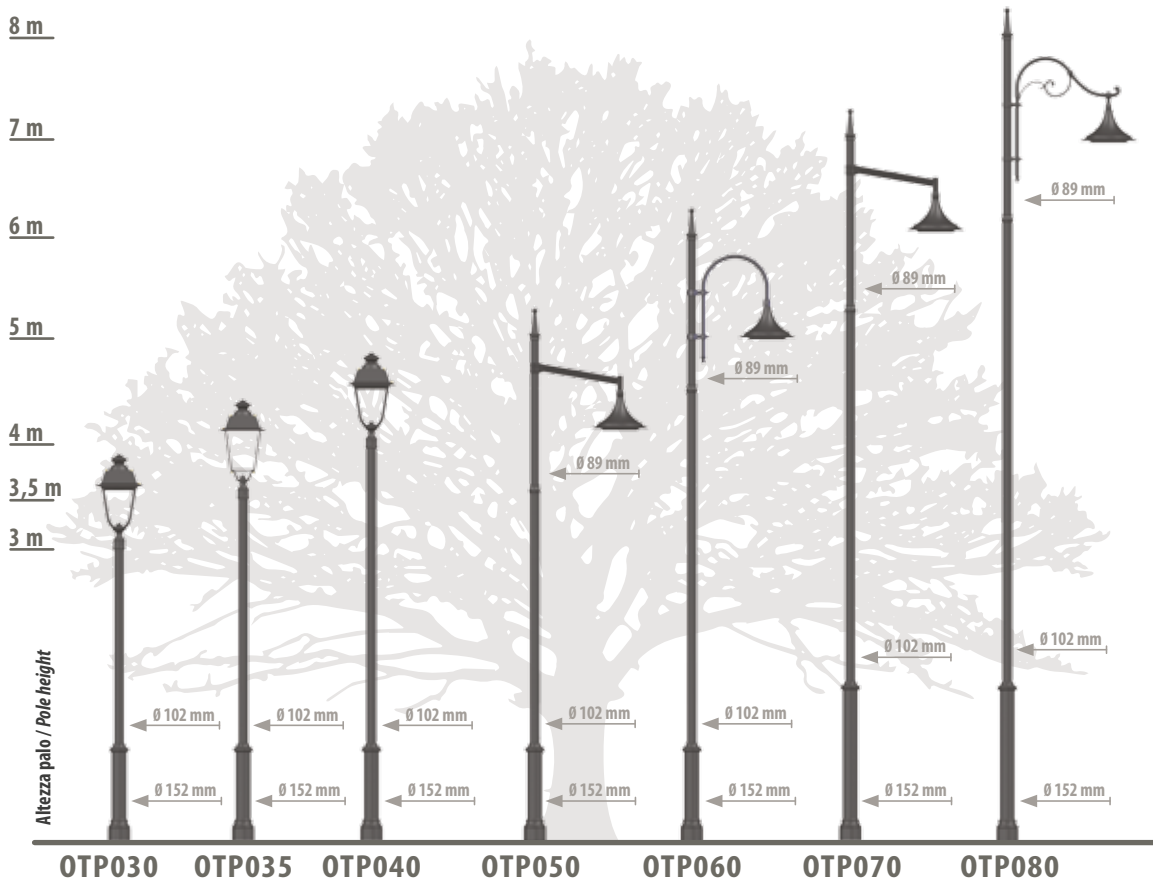

**Versioni Disponibili // Available Versions**

Tipo di fissaggio: flangia o fondazione / Fixing type: flange or foundation

Le composizioni proposte sono puramente indicative: mensole, pastorali e corpi illuminanti a scelta /  
The compositions presented are purely indicative: light fixtures and arms of your choice

**Punte Disponibili // Available Tops**



**P**  
Standard



**C**  
Su Richiesta / On Request



**M**

**Basi Palo // Pole Bases**



**OTIS10** OTP030 / OTP060  
Ø 225 mm - h 990 mm

**OTIS12** OTP070 / OTP080  
Ø 300 mm - h 1.590 mm



## QU POLE

“Qu” è una serie di pali dalla base squadrata, particolarmente indicata per mensole e corpi illuminanti in stile classico.

“Qu” is a series of poles with a square base, highly recommended for classic style arms and lighting fixtures.

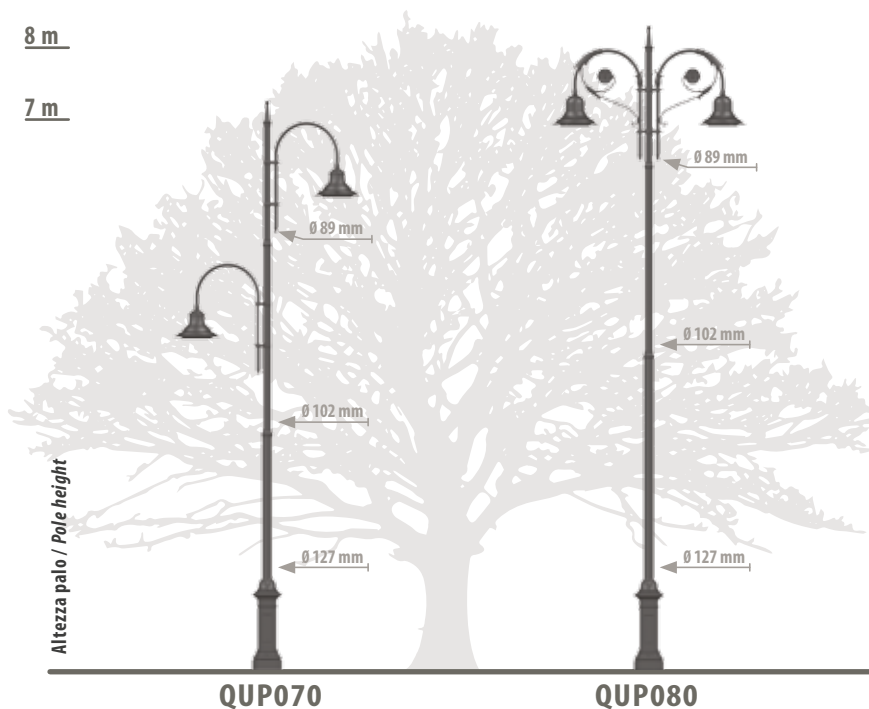

### Versioni Disponibili // Available Versions

Tipo di fissaggio: flangia o fondazione / Fixing type: flange or foundation

Le composizioni proposte sono puramente indicative: mensole, pastorali e corpi illuminanti a scelta /  
The compositions presented are purely indicative: light fixtures and arms of your choice

### Punte Disponibili // Available Tops



**P**  
Standard



**C**  
Su Richiesta / On Request



**M**

### Basi Palo // Pole Bases



**QU12** QUP070 / QUP080  
a 380 mm - h 1.155 mm

a



**illuminazione artistica // classic lighting**











## AVELLINO POLE

La base in ghisa affusolata ed elegante distingue la serie di pali "Avellino", ideali per centri storici ed aree di pregio.

*The slender and elegant cast iron base sets the series of "Avellino" poles apart, making them ideal for historical city and town centres and prestigious areas.*

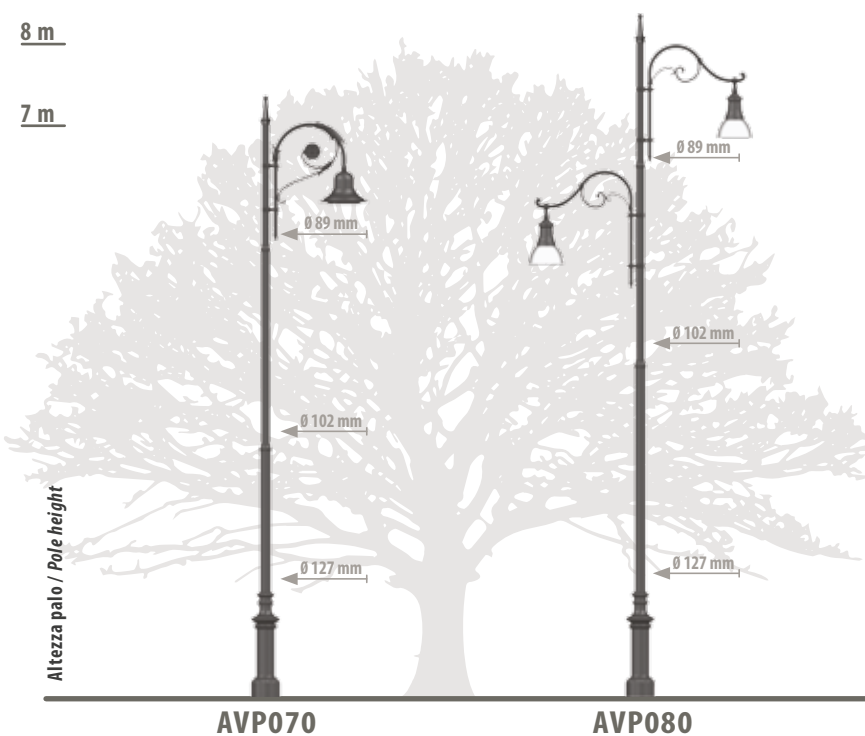

**AVP070**

**AVP080**

### Versioni Disponibili // Available Versions

Tipo di fissaggio: flangia o fondazione / Fixing type: flange or foundation

Le composizioni proposte sono puramente indicative: mensole, pastorali e corpi illuminanti a scelta /  
The compositions presented are purely indicative: light fixtures and arms of your choice

### Punte Disponibili // Available Tops



**P**  
Standard



**C**  
Su Richiesta / On Request



**M**

### Basi Palo // Pole Bases



**AVELLINO12 AVP070 / AVP080**

Ø 350 mm - h 1.270 mm



## CELIO POLE

La raffinatezza della base in ghisa infonde alla serie di pali "Celio" un'eleganza senza tempo.

*The elegance of the cast iron base instils a timeless elegance into the "Celio" series of poles.*

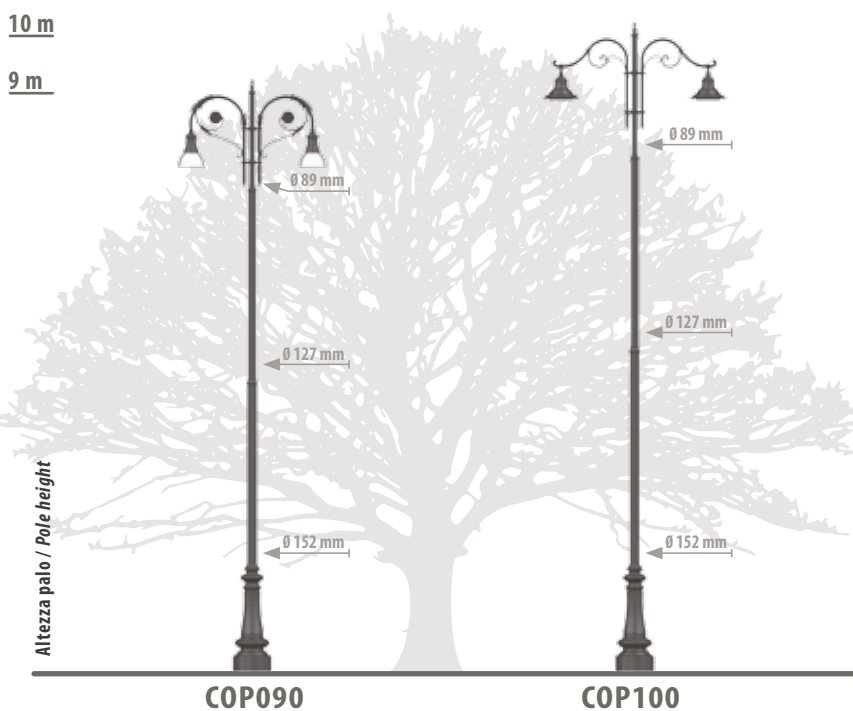

### Versioni Disponibili // Available Versions

Tipo di fissaggio: flangia o fondazione / Fixing type: flange or foundation

Le composizioni proposte sono puramente indicative: mensole, pastorali e corpi illuminanti a scelta /  
The compositions presented are purely indicative: light fixtures and arms of your choice

### Punte Disponibili // Available Tops



**M**  
Standard



**C**  
Su Richiesta / On Request



**P**

### Basi Palo // Pole Bases



**CELIO15 COP090 / COP100**  
 $\varnothing 600 \text{ mm} - h 1.665 \text{ mm}$



## ROMA POLE

La decoratività della base in ghisa rende i pali della serie "Roma" elementi monumentali di grande valore estetico, in grado di impreziosire piazze di grandi dimensioni o aree di prestigio.

*The decorative quality of the cast iron base makes the poles of the "Roma" series monumental elements of elevated aesthetic value, able to embellish large squares or prestigious areas.*

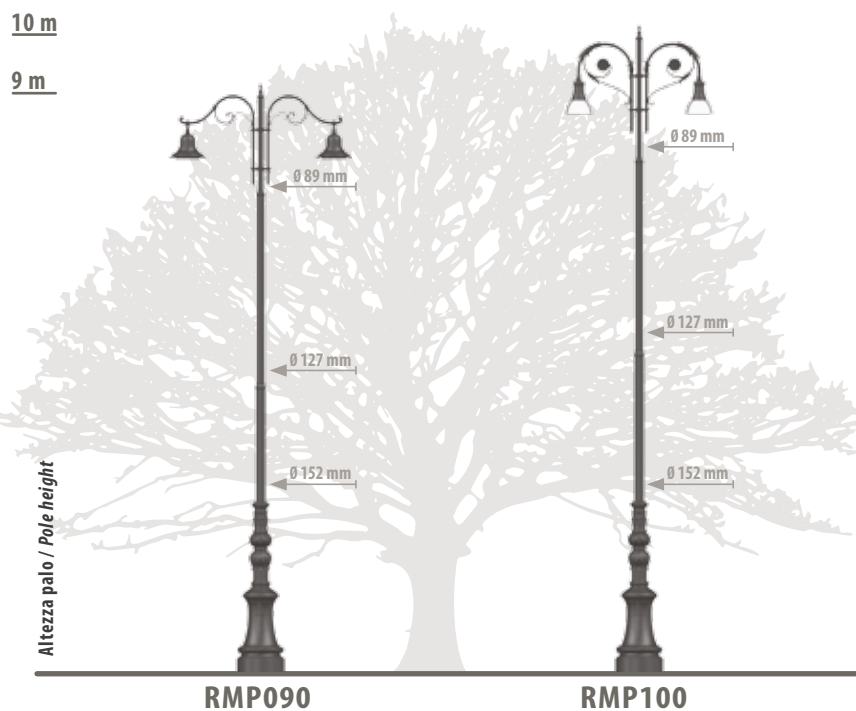

### Versioni Disponibili // Available Versions

Tipo di fissaggio: flangia o fondazione / Fixing type: flange or foundation

Le composizioni proposte sono puramente indicative: mensole, pastorali e corpi illuminanti a scelta /  
The compositions presented are purely indicative: light fixtures and arms of your choice

### Punte Disponibili // Available Tops



**M**  
Standard



**C**  
Su Richiesta / On Request



**P**

### Basi Palo // Pole Bases



**ROMA15** RMP090 / RMP100  
Ø 745 mm - h 2.705 mm



**illuminazione artistica // classic lighting**







## ACI POLE-TOP SYSTEM

“Aci” è un sistema che infonde eleganza e stile. Può essere abbinato a tutte le serie di pali ghisa-acciaio con soluzioni testa-palo.

*“Aci” is a pole-top system which instils elegance and style. It can be matched with all the series of cast iron steel poles with pole-head solutions.*



### **Versioni Disponibili // Available Versions**

Sistema cima-palo per pali di altezza 3 - 3,5 - 4 mt /  
Pole-top system on 3 - 3,5 - 4 mt poles





**BK POLE-TOP SYSTEM**

“Bk” è un sistema cima-palo dal design classico, che consente di inserire più corpi illuminanti. È disponibile in più configurazioni per consentire una maggiore versatilità di utilizzo.

*“Bk” is a pole-top system with a classic design which allows to insert more lighting fixtures. It is available in more configurations to increase its versatility.*

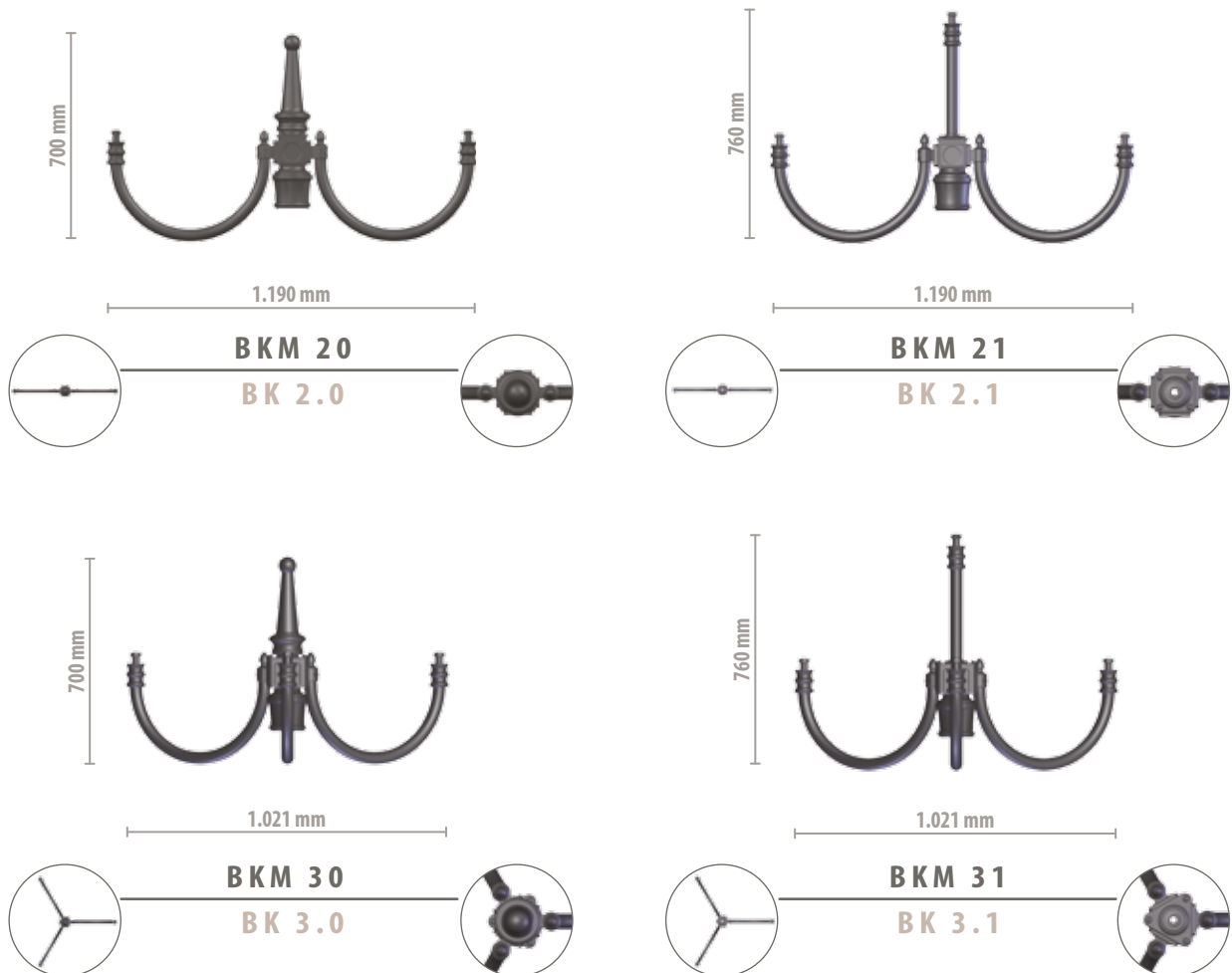

**Versioni Disponibili // Available Versions**

- Sistema cima-palo per pali di altezza 3 - 3,5 - 4 mt / Pole-top system on 3 - 3,5 - 4 mt poles
- 2.0 due corpi illuminanti laterali / 2.0 two side light fixtures
- 2.1 due corpi illuminanti laterali e uno testa-palo / 2.1 two side light fixtures and one pole-top
- 3.0 tre corpi illuminanti laterali / 3.0 three side light fixtures
- 3.1 tre corpi illuminanti laterali e uno testa-palo / 3.1 three side light fixtures and one pole-top



**illuminazione artistica // classic lighting**







## VELA POLE ARM

“Vela” si distingue per la semplicità del profilo arcuato. È disponibile in due formati e in due versioni, per corpi illuminanti a sospensione e con attacco laterale.

*“Vela” sets itself apart for the simplicity of the curved profile. It is available in two versions and sizes, for suspended light fixtures and with side fixing.*



(S) 752 mm · (L) 1.137 mm

**VEM S A (small) · VEM L A (large)**

**VELA A**



(S) 785 mm · (L) 1.107 mm

**VEM S B (small) · VEM L B (large)**

**VELA B**

### Versioni Disponibili // Available Versions

VEM S A - VEM S B disponibile in versione singola o doppia per pali di altezza 5 - 6 mt /

VEM S A - VEM S B available in single or double versions on 5 - 6 mt poles

VEM L A - VEM L B disponibile in versione singola, doppia, tripla o quadrupla per pali di altezza 7 - 8 - 9 - 10 mt /

VEM L A - VEM L B available in single, double, triple or quad versions on 7 - 8 - 9 - 10 mt poles



## ORIONE, SIRIO POLE ARMS

“Orione” e “Sirio” sono due mensole a palo in stile moderno. Sono disponibili in due formati e in un’unica versione per corpi illuminanti a sospensione.

“Orione” and “Sirio” are two modern style pole arms. They are available in two sizes and in one single version for suspended light fixtures.

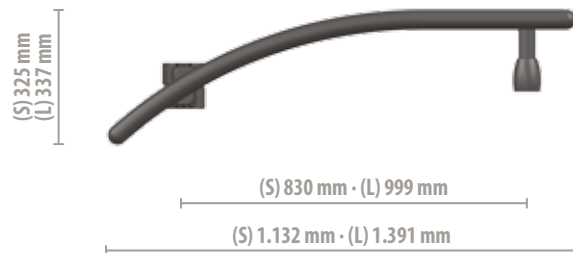

**ORM S (small) · ORM L (large)**

**ORIONE**

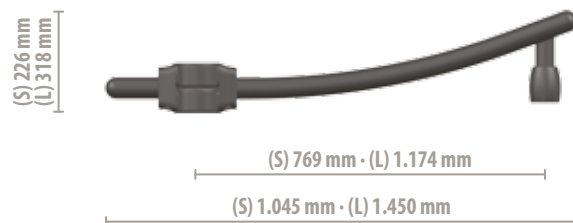

**SIM S (small) · SIM L (large)**

**SIRIO**

### Versioni Disponibili // Available Versions

ORM S - SIM S disponibile in versione singola o doppia per pali di altezza 5 - 6 mt /

ORM S - SIM S available in single or double versions on 5 - 6 mt poles

ORM L - SIM L disponibile in versione singola, doppia, tripla o quadrupla per pali di altezza 7 - 8 - 9 - 10 mt /

ORM L - SIM L available in single, double, triple or quad versions on 7 - 8 - 9 - 10 mt poles



**Illuminazione artistica // classic lighting**







## TIRO POLE ARM

“Tiro”, semplice e lineare, è una mensola disponibile in due formati per corpi illuminanti a sospensione.

*“Tiro” is a simple and linear arm available in two sizes for suspended light fixtures.*



### Versioni Disponibili // Available Versions

TIM S disponibile in versione singola o doppia per pali di altezza 5 - 6 mt / TIM S available in single or double versions on 5 - 6 mt poles

TIM L disponibile in versione singola, doppia, tripla o quadrupla per pali di altezza 7 - 8 - 9 - 10 mt /

TIM L available in single, double, triple or quad versions on 7 - 8 - 9 - 10 mt poles



## COLIBRÌ POLE ARM

“Colibrì” è una mensola a palo di grande carattere, in grado di trasmettere il proprio stile. È disponibile in due formati per corpi illuminanti con attacco laterale.

*“Colibrì” is a large pole arm, capable of communicating its style. It is available in two sizes for light fixtures with side fixting.*



### Versioni Disponibili // Available Versions

COM S disponibile in versione singola o doppia per pali di altezza 5 - 6 mt / COM S available in single or double versions on 5 - 6 mt poles

COM L disponibile in versione singola o doppia per pali di altezza 7 - 8 - 9 - 10 mt /

COM L available in single or double versions on 7 - 8 - 9 - 10 mt poles



**Illuminazione artistica // classic lighting**







## MILVA POLE ARM

“Milva” è una mensola a palo in stile classico, disponibile in due formati per corpi illuminanti a sospensione.

*“Milva” is a classic style pole arm, available in two formats for suspended light fixtures.*



### Versioni Disponibili // Available Versions

MIM S disponibile in versione singola o doppia per pali di altezza 5 - 6 mt / MIM S available in single or double versions on 5 - 6 mt poles

MIM L disponibile in versione singola, doppia, tripla o quadrupla per pali di altezza 7 - 8 - 9 - 10 mt /

MIM L available in single, double, triple or quad versions on 7 - 8 - 9 - 10 mt poles





## FLIPPY POLE ARM

“Flippy” è una mensola a palo caratterizzata dall’ovulo di raccordo che segna l’attacco del corpo illuminante. È disponibile in due formati.

*“Flippy” is characterised by the joining ovule which marks the attachment of the fixture. The pole arm is available in two formats.*

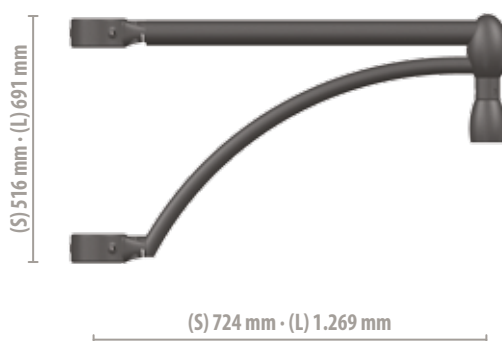

**FLM S (small) · FLM L (large)**

**FLIPPY**

### **Versioni Disponibili // Available Versions**

FLM S disponibile in versione singola o doppia per pali di altezza 5 - 6 mt /

FLM S available in single or double versions on 5 - 6 mt poles

FLM L disponibile in versione singola, doppia, tripla o quadrupla per pali di altezza 7 - 8 - 9 - 10 mt /

FLM L available in single, double, triple or quad versions on 7 - 8 - 9 - 10 mt poles





## TENCO POLE ARM

La decoratività della mensola a palo "Tenco" la rende perfetta per installazioni in stile classico. È disponibile in due formati per corpi illuminanti con attacco a sospensione.

*The decorative quality of the "Tenco" pole arm makes it ideal for classic style poles. The pole arm is available in two formats for light fixtures with suspended attachment.*

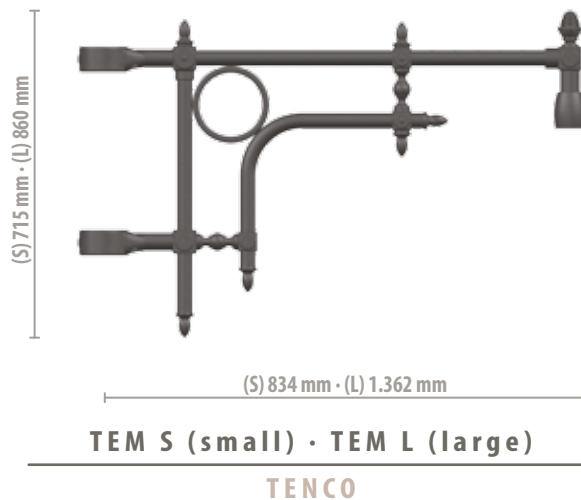

### Versioni Disponibili // Available Versions

TEM S disponibile in versione singola o doppia per pali di altezza 5 - 6 mt /

TEM S available in single or double versions on 5 - 6 mt poles

TEM L disponibile in versione singola, doppia, tripla o quadrupla per pali di altezza 7 - 8 - 9 - 10 mt /

TEM L available in single, double, triple or quad versions on 7 - 8 - 9 - 10 mt poles



## TRALI POLE ARM

“Trali”, caratterizzata dal tirante in acciaio inox, è una mensola disponibile in due formati per corpi illuminanti con attacco a sospensione.

*“Trali” is a pole arm available in two formats for light fixtures with suspended attachment, characterised by the stainless-steel tie-rod.*

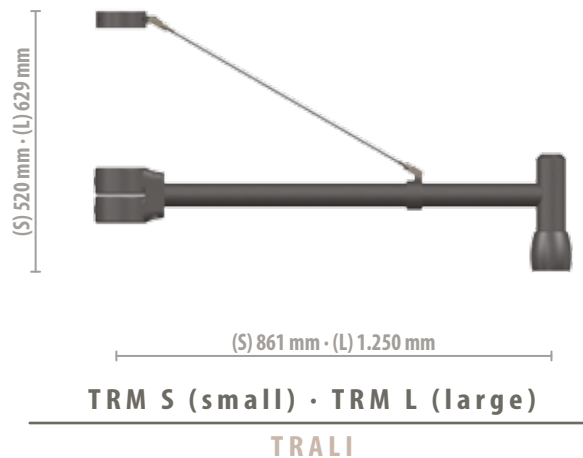

### Versioni Disponibili // Available Versions

TRM S disponibili nella versione singola o doppia per pali di altezza 5 - 6 mt /

TRM S available in single or double versions on 5 - 6 mt poles

TRM L disponibili nella versione singola, doppia, tripla o quadrupla per pali di altezza 7 - 8 - 9 - 10 mt /

TRM L available in single, double, triple or quad versions on 7 - 8 - 9 - 10 mt poles



## OLBIA POLE ARM

“Olbia” è una mensola a palo che sfrutta appieno la potenzialità del tirante in acciaio inox. È disponibile in due formati per corpi illuminanti con attacco a sospensione.

*“Olbia” is a pole arm which makes full use of the potential of the stainless-steel tie-rod. It is available in two formats for light fixtures with suspended attachment.*

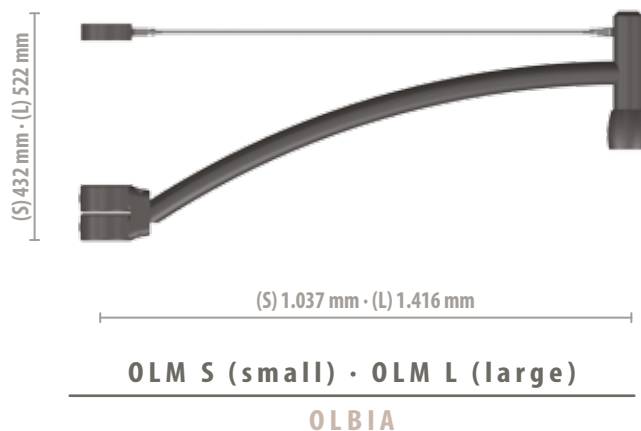

### **Versioni Disponibili // Available Versions**

OLM S disponibile in versione singola o doppia per pali di altezza 5 - 6 mt /

OLM S available in single or double versions on 5 - 6 mt poles

OLM L disponibile in versione singola, doppia, tripla o quadrupla per pali di altezza 7 - 8 - 9 - 10 mt /

OLM L available in single, double, triple or quad versions on 7 - 8 - 9 - 10 mt poles



**illuminazione artistica // classic lighting**







**LP, VAL, IMC POLE ARMS**

GMR ENLIGHTS propone tre modelli di pastorale adatti ad ogni esigenza: "Lp", semplice e lineare, "Val", elegante e distinto e "Imc", decorato e ricercato.

*GMR ENLIGHTS offers three models of crosier pole arms, suited to accommodate every need: "Lp", simple and linear, "Val" elegant and distinguished, and "Imc", decorated and sophisticated.*



(S) 735 mm • (L) 934 mm

**LPS S (small) • LPS L (large)**

**LP**



(S) 871 mm • (L) 1.131 mm

**VLS S (small) • VLS L (large)**

**VAL**



(S) 735 mm • (L) 934 mm

**IMS S (small) • IMS L (large)**

**IMC**

**Versioni Disponibili // Available Versions**

LPS S - VLS S - IMS S disponibili nelle versioni singola o doppia per pali di altezza 5 - 6 mt /

LPS S - VLS S - IMS S available in single or double versions on 5 - 6 mt poles

LPS L - VLS L - IMS L disponibili nelle versioni singola, doppia, tripla o quadrupla per pali di altezza 7 - 8 - 9 - 10 mt /

LPS L - VLS L - IMS L available in single, double, triple or quad versions on 7 - 8 - 9 - 10 mt poles



**illuminazione artistica // classic lighting**









## SIRIO, VELA, TIRO WALL BRACKETS

“Sirio”, “Vela” e “Tiro”: mensole a muro dal design lineare e moderno abbinabili a tutti i corpi illuminanti artistici.

*“Sirio”, “Vela” and “Tiro” are linear and modern design wall brackets which can be matched to all classic lighting fixtures.*



740 mm

**SIW**

**SIRIO**



852 mm

**TIW**

**TIRO**



731 mm

**VEW A**

**VELA A**



759 mm

**VEW B**

**VELA B**



**MILVA, FLIPPY, TENCO WALL BRACKETS**

“Milva”, “Flippy” e “Tenco” sono mensole a muro in stile classico caratterizzate da un’estetica intramontabile.

“Milva”, “Flippy” and “Tenco” are wall brackets with a very classic look, a true timeless design.

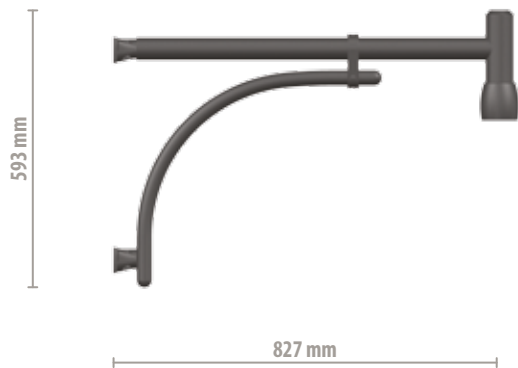

**MIW**  
**MILVA**

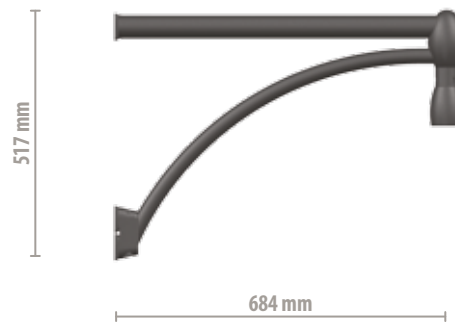

**FLW**  
**FLIPPY**

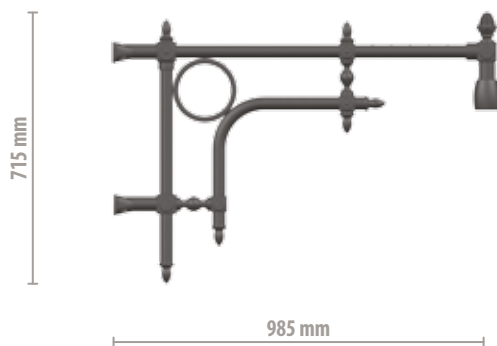

**TEW A**  
**TENCO A**

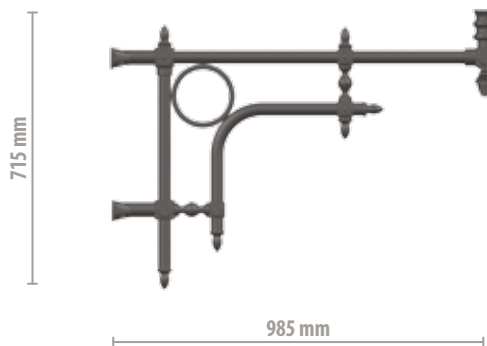

**TEW C**  
**TENCO C**



**FE WALL BRACKET**

“Fe”, per i suoi decori sinuosi e per l’artisticità delle forme, è una mensola a muro particolarmente indicata per contesti storici.

*“Fe” is a wall bracket highly recommended for historical settings thanks to its sinuous decorations and the artistic nature of its shapes.*

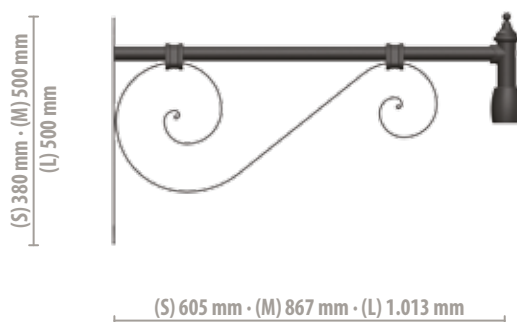

**FEW S A (small) • FEW M A (medium) • FEW L A (large)**

**FE A**

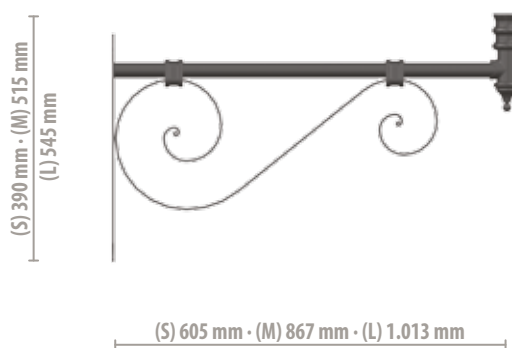

**FEW S C (small) • FEW M C (medium) • FEW L C (large)**

**FE C**



**Illuminazione artistica // classic lighting**









## LP, VAL, IMC WALL BRACKETS

“Lp”, “Val” e “Imc”: tre modelli di pastorale a muro per rispondere a qualsiasi esigenza.

“Lp”, “Val” and “Imc” are three models of wall crozier wall brackets to satisfy any need.



**LPW**

**LP**



**VLW**

**VAL**



**IMW**

**IMC**

**illuminazione artistica // classic lighting**









**Illuminazione artistica //**  
*classic lighting*

672 **REGOLE DI COMPOSIZIONE //** COMPOSITION RULES

**PALI // poles**

516 **OVULI** CAST-IRON POLE [ 10 ]

518 **OVULI** CAST-IRON POLE [ 12 ]

522 **BERTY** CAST-IRON POLE [ 10 ]

524 **BERTY** CAST-IRON POLE [ 12 ]

528 **CAR** CAST-IRON POLE [ 10 ]

530 **CAR** CAST-IRON POLE [ 12 ]

532 **CAR SB** CAST-IRON POLE [ 10 ]

534 **CAR SB** CAST-IRON POLE [ 12 ]

538 **CQC** CAST-IRON POLE [ 10 ]

540 **CQC** CAST-IRON POLE [ 12 ]

544 **QU** CAST-IRON POLE [ 10 ]

546 **BO** CAST-IRON POLE [ 12 ]

550 **VENEZIA** CAST-IRON POLE

554 **ROMA** CAST-IRON POLE

**SISTEMI CIMA-PALO // pole-top systems**

558 **25** CAST-IRON POLE-TOP SYSTEM [ S ]

560 **25** CAST-IRON POLE-TOP SYSTEM [ L ]

562 **30** CAST-IRON POLE-TOP SYSTEM [ S ]

564 **30** CAST-IRON POLE-TOP SYSTEM [ L ]

566 **VENEZIA** CAST-IRON POLE-TOP SYSTEM [ S ]

568 **VENEZIA** CAST-IRON POLE-TOP SYSTEM [ L ]

**MENSOLE A PALO // pole arms**

570 **LP, VAL, IMC** POLE ARMS

**MENSOLE A MURO // wall brackets**

576 **25, 30** CAST-IRON WALL BRACKETS

578 **VENEZIA** CAST-IRON WALL BRACKET

580 **50, CRIS** CAST-IRON WALL BRACKETS

582 **1864, 1861** CAST-IRON WALL BRACKETS

# ghisa

## *cast-iron*

La bellezza e il fascino della tradizione sono gli elementi fondanti di una collezione di prodotti il cui stile va dalle linee classiche ed eleganti all'estrema decorazione floreale.

*The beauty and charm of tradition are the core elements of a collection of products with a style that ranges from classic elegant lines to extreme floral decoration.*

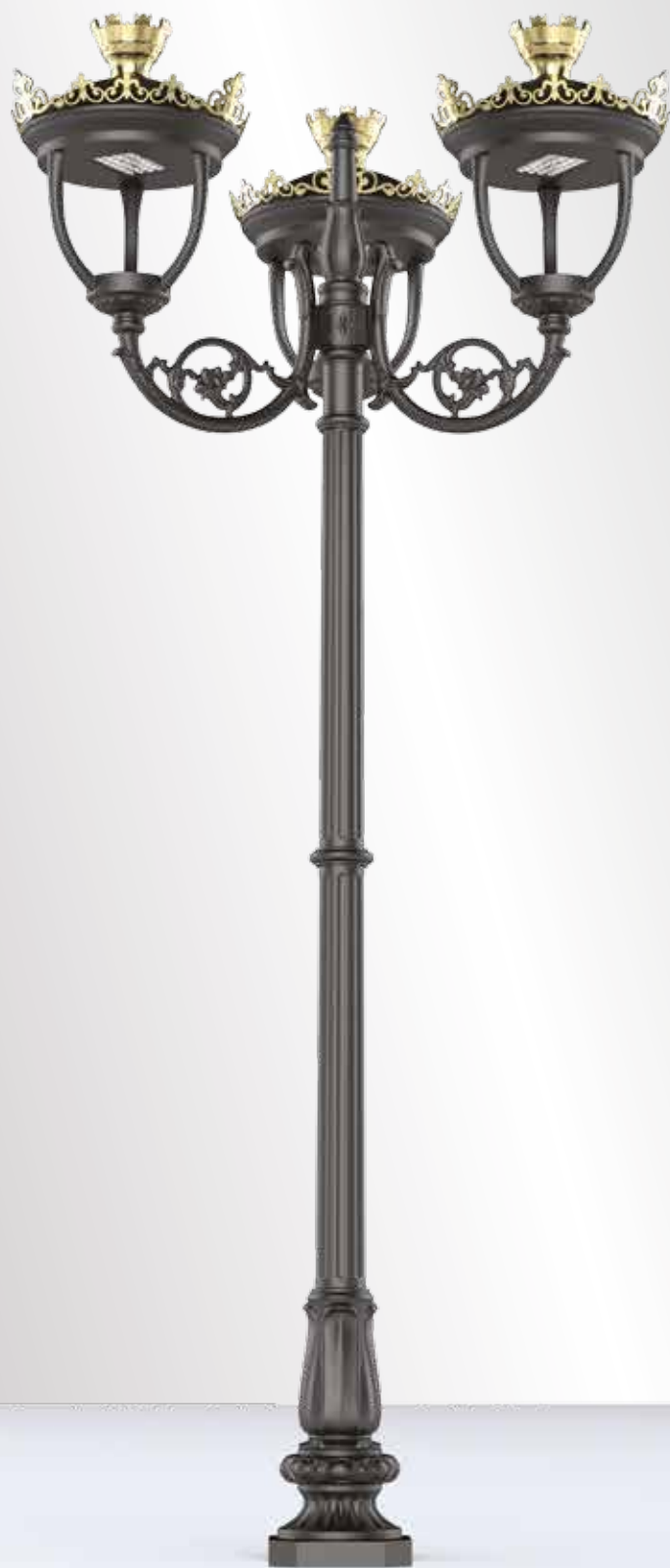

## OVULI CAST-IRON POLE [10]

“Ovuli” è una serie di pali in ghisa resa preziosa dalla piccola base finemente decorata. La serie è perfetta per aree eleganti e di pregio.

*“Ovuli” is a series of cast iron poles made precious by the small exquisitely decorated base. Ideal for elegant and prestigious areas.*

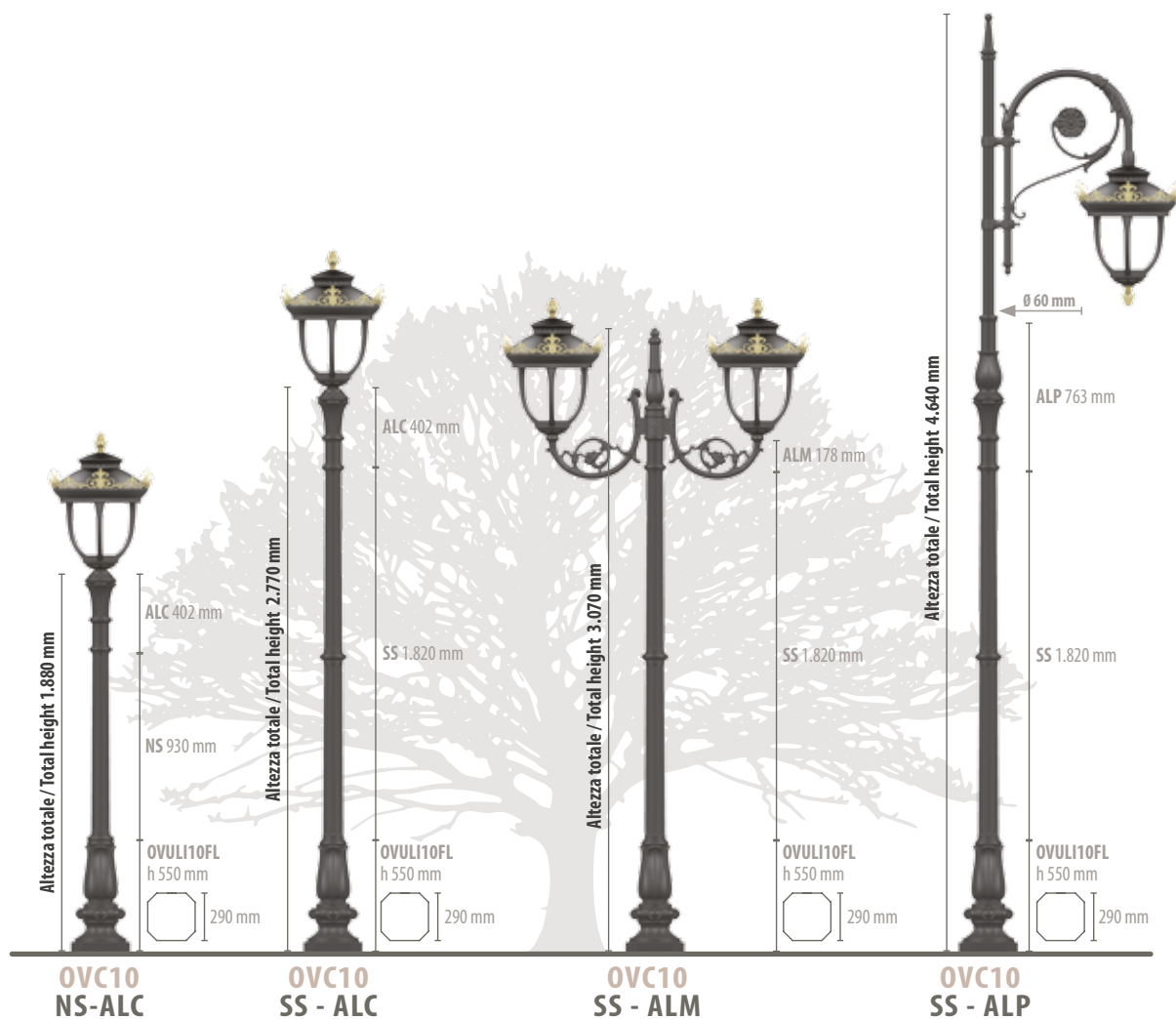

### Versioni Disponibili // Available Versions

Tipo di fissaggio: flangia o fondazione / Fixing type: flange or foundation

Le composizioni proposte sono puramente indicative: sistemi cima-palo, pastorali e corpi illuminanti a scelta / The compositions presented are purely indicative: light fixtures, pole top-systems and arms of your choice



**OVULI CAST-IRON POLE [12]**

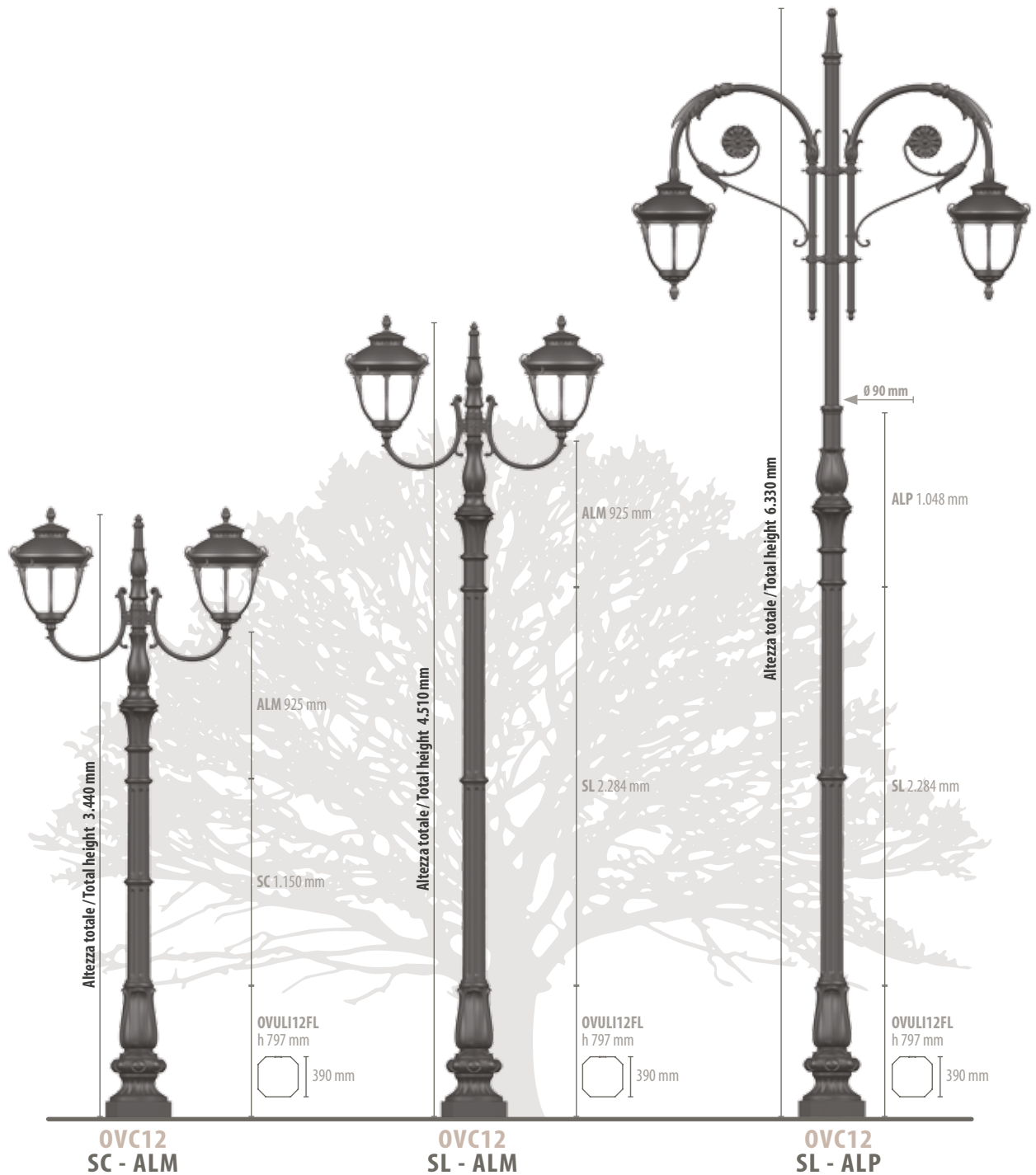

**Versioni Disponibili // Available Versions**

Tipo di fissaggio: flangia o fondazione / Fixing type: flange or foundation

Le composizioni proposte sono puramente indicative: sistemi cima-palo, pastorali e corpi illuminanti a scelta /  
The compositions presented are purely indicative: light fixtures, pole top-systems and arms of your choice

Vedi regole di composizione a p. 572 // Refer to p. 572 for composition rules



**illuminazione artistica // classic lighting**







## BERTY CAST-IRON POLE [10]

La serie di pali "Berty" si sviluppa su più altezze e si distingue per l'estetica intramontabile della base circolare.

*The "Berty" series is available in many different sizes. The timeless design of the circular base is what sets this piece apart.*

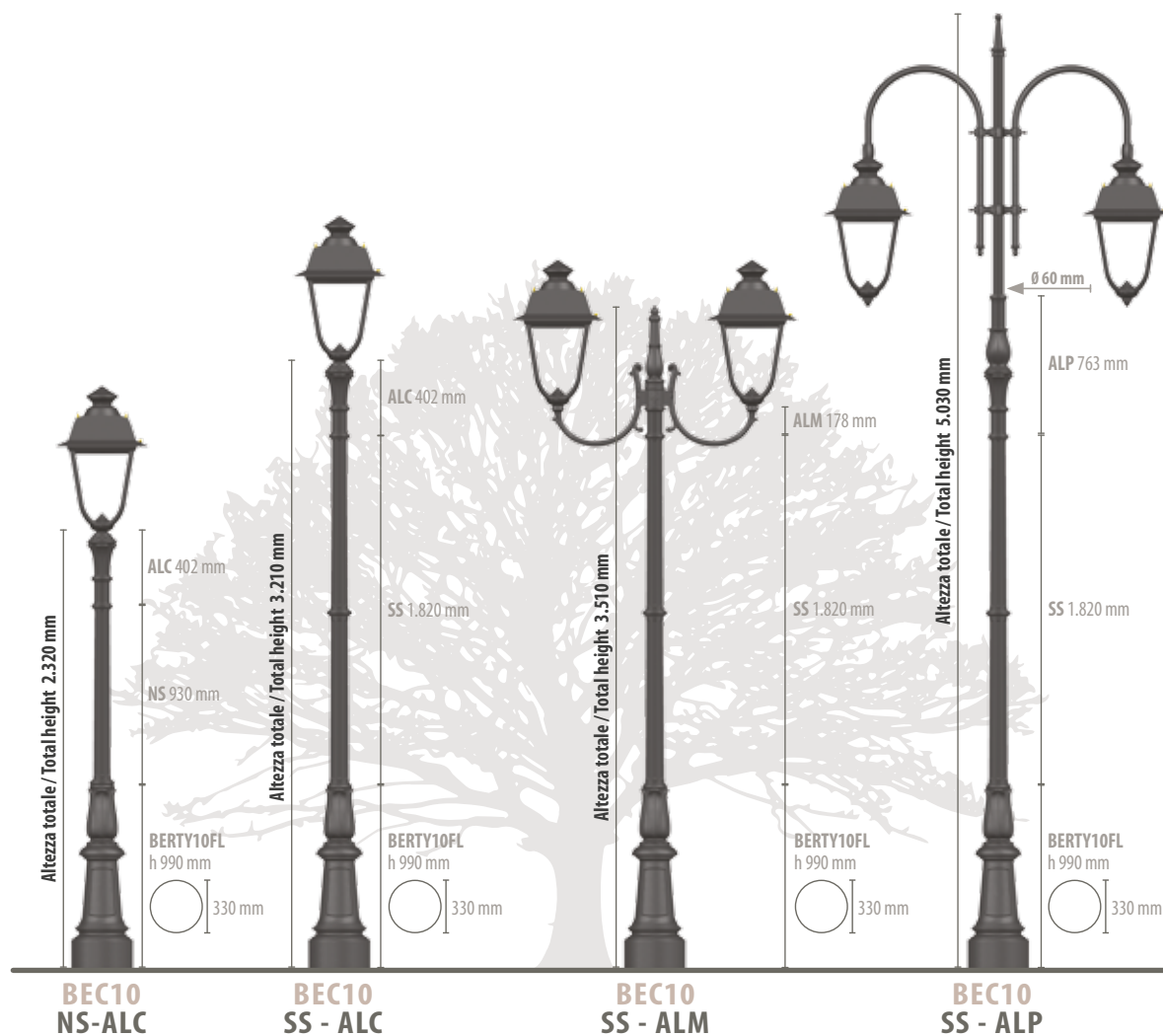

### Versioni Disponibili // Available Versions

Tipo di fissaggio: flangia o fondazione / Fixing type: flange or foundation

Le composizioni proposte sono puramente indicative: sistemi cima-palo, pastorali e corpi illuminanti a scelta / The compositions presented are purely indicative: light fixtures, pole top-systems and arms of your choice





**BERTY CAST-IRON POLE [12]**

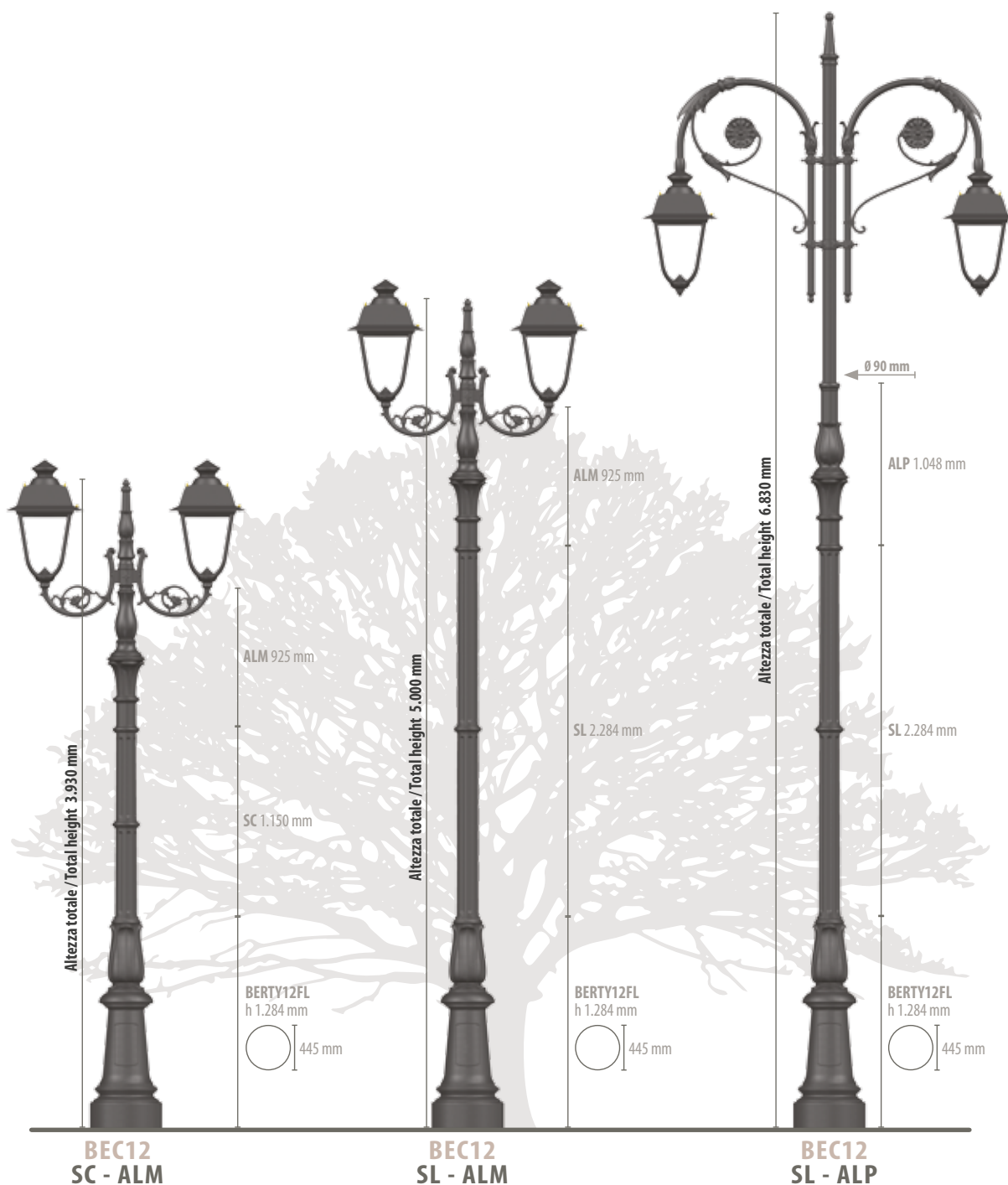

**Versioni Disponibili // Available Versions**

Tipo di fissaggio: flangia o fondazione / Fixing type: flange or foundation

Le composizioni proposte sono puramente indicative: sistemi cima-palo, pastorali e corpi illuminanti a scelta /

The compositions presented are purely indicative: light fixtures, pole top-systems and arms of your choice

Vedi regole di composizione a p. 572 // Refer to p. 572 for composition rules



**illuminazione artistica // classic lighting**







## CAR CAST-IRON POLE [10]

Il taglio tradizionale e semplice della serie di pali in ghisa "Car" la rende adatta ad una molteplicità di contesti e perfetta in abbinamento a tutte le tipologie di sistemi cima-palo e pastorali della collezione.

*The "Car" pole series is suited for many different urban areas thanks to its simple and traditional design, enriched by the pole heads and brackets in the collection.*



### Versioni Disponibili // Available Versions

Tipo di fissaggio: flangia o fondazione / Fixing type: flange or foundation

Le composizioni proposte sono puramente indicative: sistemi cima-palo, pastorali e corpi illuminanti a scelta / The compositions presented are purely indicative: light fixtures, pole top-systems and arms of your choice



**CAR CAST-IRON POLE [12]**



**Versioni Disponibili // Available Versions**

Tipo di fissaggio: flangia o fondazione / Fixing type: flange or foundation

Le composizioni proposte sono puramente indicative: sistemi cima-palo, pastorali e corpi illuminanti a scelta /

The compositions presented are purely indicative: light fixtures, pole top-systems and arms of your choice

Vedi regole di composizione a p. 572 // Refer to p. 572 for composition rules





## CAR SB CAST-IRON POLE [10]

“Car SB” è una serie di pali dalla base classica e imponente, perfetta per aree eleganti e di pregio.

“CarSB” is a series of poles with a classic and impressive base, ideal for elegant and prestigious areas.

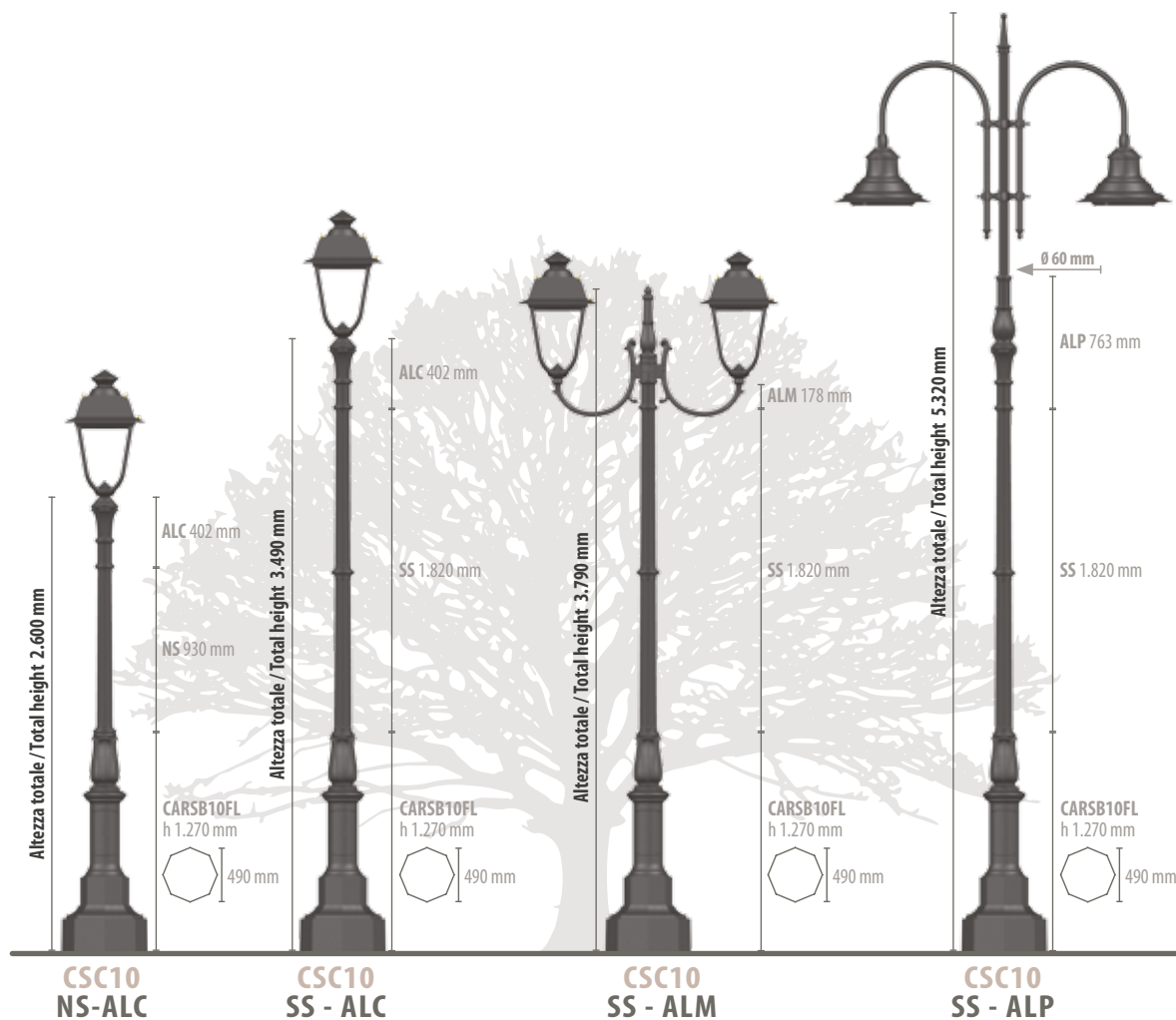

### Versioni Disponibili // Available Versions

Tipo di fissaggio: flangia o fondazione / Fixing type: flange or foundation

Le composizioni proposte sono puramente indicative: sistemi cima-palo, pastorali e corpi illuminanti a scelta /  
The compositions presented are purely indicative: light fixtures, pole top-systems and arms of your choice



**CAR SB CAST-IRON POLE [12]**



**Versioni Disponibili // Available Versions**

Tipo di fissaggio: flangia o fondazione / Fixing type: flange or foundation

Le composizioni proposte sono puramente indicative: sistemi cima-palo, pastorali e corpi illuminanti a scelta /  
The compositions presented are purely indicative: light fixtures, pole top-systems and arms of your choice

Vedi regole di composizione a p. 572 // Refer to p. 572 for composition rules

**Illuminazione artistica // classic lighting**











## CQC CAST-IRON POLE [10]

La tradizione scultorea classica è ciò che ha ispirato la complessità decorativa della serie "Cqc": ovuli finemente incisi, festoni e disegni floreali rendono questi pali elementi unici.

*Classical sculptural tradition is what inspired the "Cqc" series: finely engraved ovules, festoons and floral designs make these poles unique.*

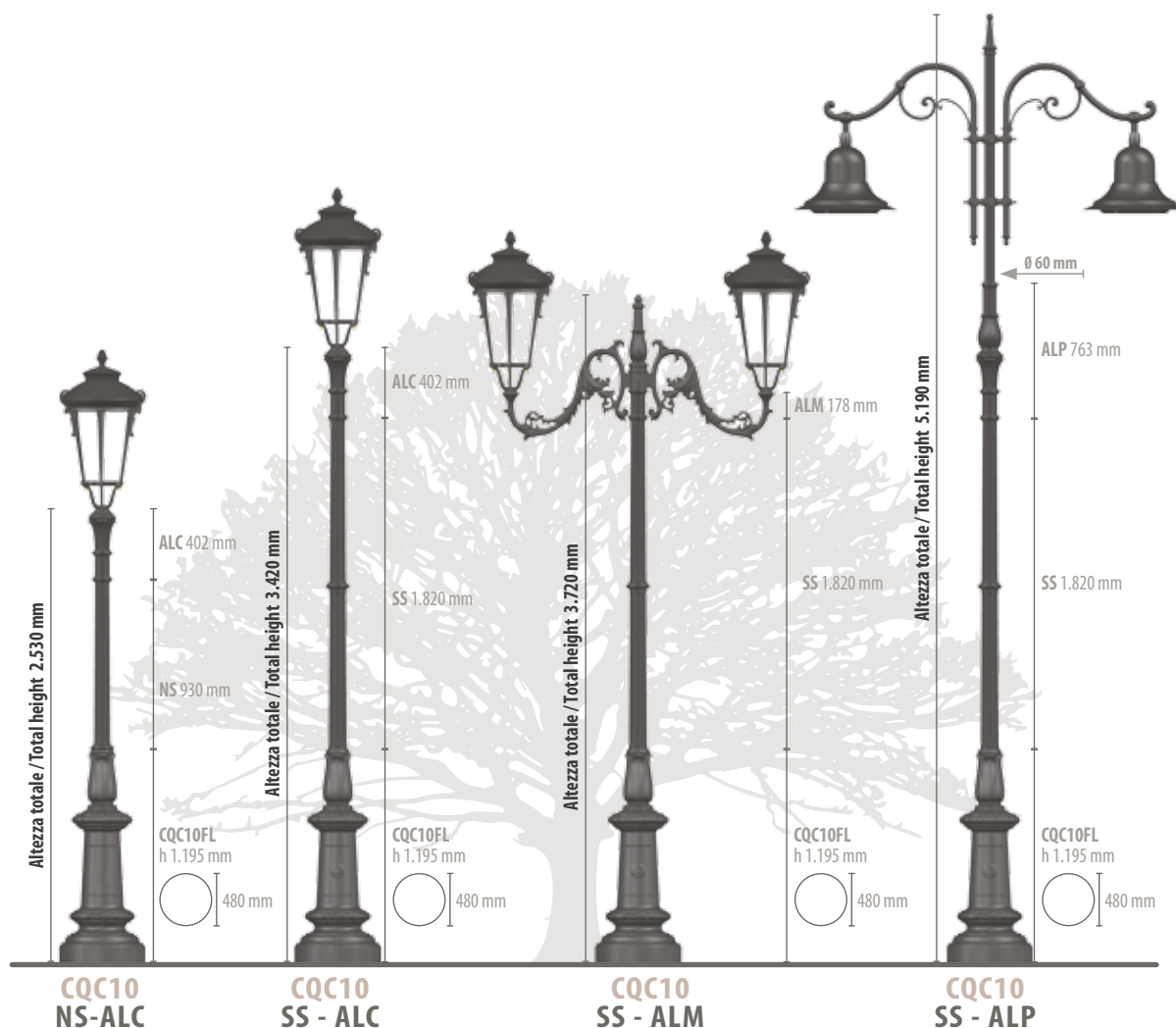

### Versioni Disponibili // Available Versions

Tipo di fissaggio: flangia o fondazione / Fixing type: flange or foundation

Le composizioni proposte sono puramente indicative: sistemi cima-palo, pastorali e corpi illuminanti a scelta / The compositions presented are purely indicative: light fixtures, pole top-systems and arms of your choice



**CQC CAST-IRON POLE [12]**

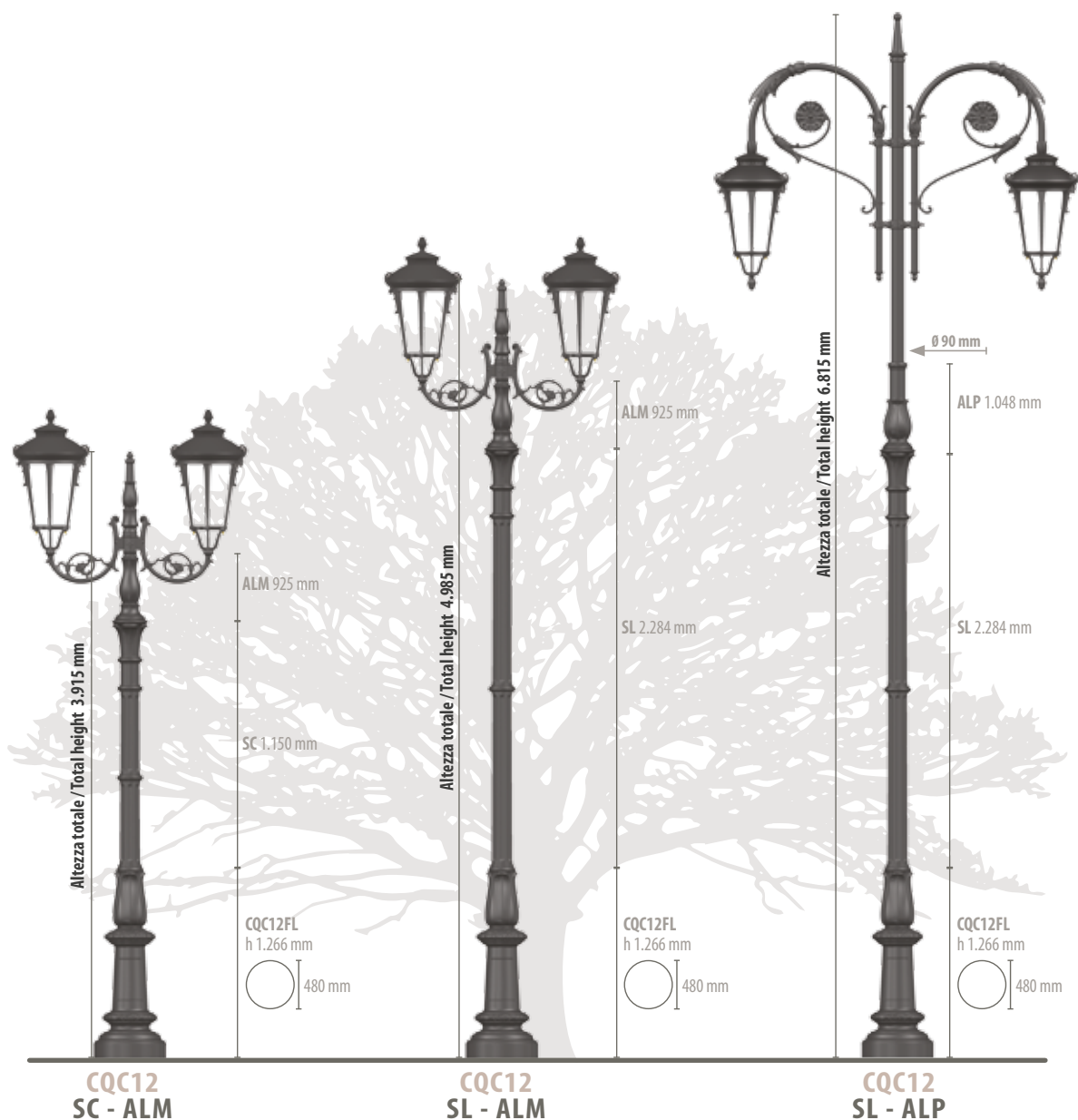

**Versioni Disponibili // Available Versions**

Tipo di fissaggio: flangia o fondazione / Fixing type: flange or foundation

Le composizioni proposte sono puramente indicative: sistemi cima-palo, pastorali e corpi illuminanti a scelta /  
The compositions presented are purely indicative: light fixtures, pole top-systems and arms of your choice

Vedi regole di composizione a p. 572 // Refer to p. 572 for composition rules

**illuminazione artistica // classic lighting**











## QU CAST-IRON POLE [10]

La maestosità, combinata alla raffinatezza decorativa della base in ghisa, rende la serie di pali "Qu" in grado di nobilitare i contesti in cui viene inserita.

*The splendour combined with the decorative elegance of the cast iron base makes the "Qu" series of poles able to raise the prestige of the settings in which it is installed.*

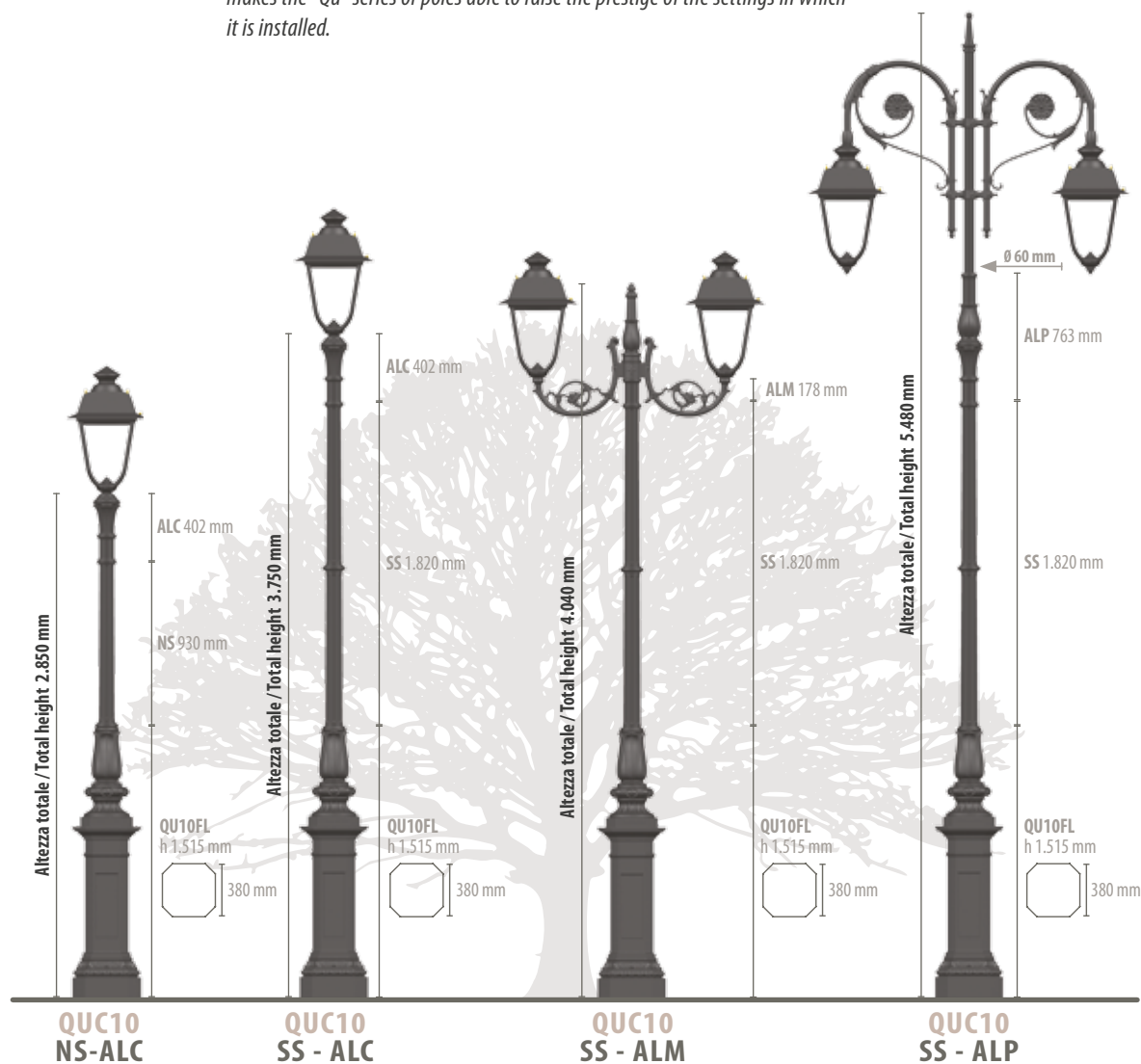

### Versioni Disponibili // Available Versions

Tipo di fissaggio: flangia o fondazione / Fixing type: flange or foundation

Le composizioni proposte sono puramente indicative: sistemi cima-palo, pastorali e corpi illuminanti a scelta /

The compositions presented are purely indicative: light fixtures, pole top-systems and arms of your choice



**BO CAST-IRON POLE [12]**

“Bo” è una serie di pali dalla base ottagonale sormontata da decori ad ovuli e foglie. Per la sua imponenza è particolarmente indicata per aree di notevole interesse.

“Bo” is a series of poles with an octagonal base topped by ovules and leaf decorations. Highly recommended for areas of considerable interest due to its imposing style.

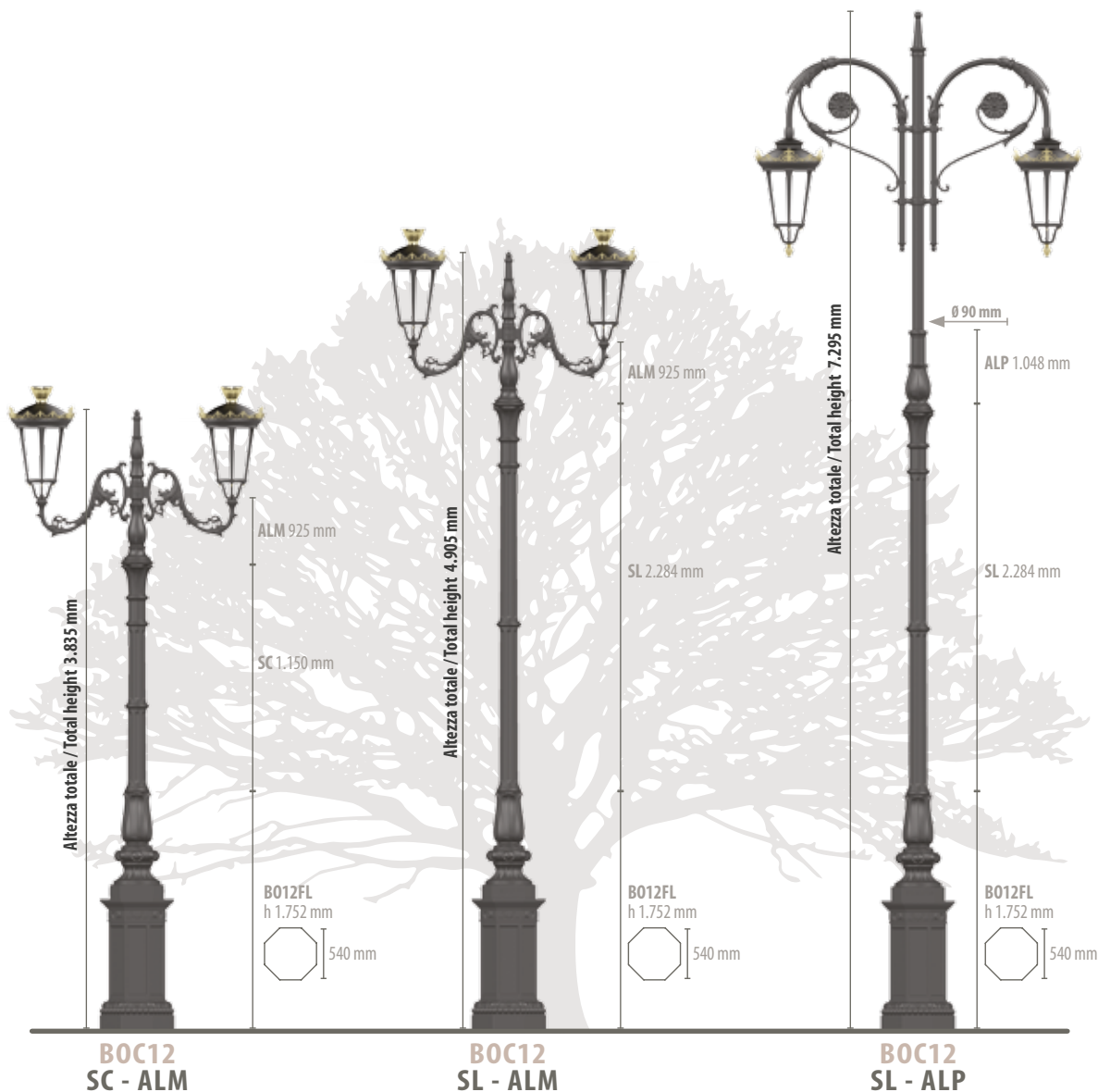

**Versioni Disponibili // Available Versions**

Tipo di fissaggio: flangia o fondazione / Fixing type: flange or foundation

Le composizioni proposte sono puramente indicative: sistemi cima-palo, pastorali e corpi illuminanti a scelta /  
The compositions presented are purely indicative: light fixtures, pole top-systems and arms of your choice

Vedi regole di composizione a p. 572 // Refer to p. 572 for composition rules

**illuminazione artistica // classic lighting**











## VENEZIA CAST-IRON POLE

“Venezia” è lo storico palo che arreda con eleganza Piazza San Marco. La raffinatezza dell’apparato decorativo della base e della colonna infonde al palo quel carattere romantico e ricercato che lo rende un oggetto unico.

*“Venezia” is the historical pole which elegantly furnishes St. Mark’s Square in Venice, Italy. The elegance of the decorative element of the base and of the column gives the pole that refined and elegant look which makes it unique.*



### Versioni Disponibili // Available Versions

Tipo di fissaggio: flangia o fondazione / Fixing type: flange or foundation

Sul palo è possibile installare a scelta un modello di sistema cima-palo VENEZIA LARGE p. 566 /  
On the pole, the client can choose to install a VENEZIA LARGE pole-top system model p. 566

**illuminazione artistica // classic lighting**









## ROMA CAST-IRON POLE

Le fini volumetriche della base, gli ornamenti a festoni e ghirlande della foglia, le scanalature e la decorazione floreale della colonna rendono il palo "Roma" un elemento scultoreo e imponente, degno di arredare il cuore della città eterna da cui prende il nome.

*The elegant volumes of the base, the festoons, garlands and leaves make the "Roma" pole a sculptural and imposing element, worthy of decorating the heart of the city which gives it its name.*

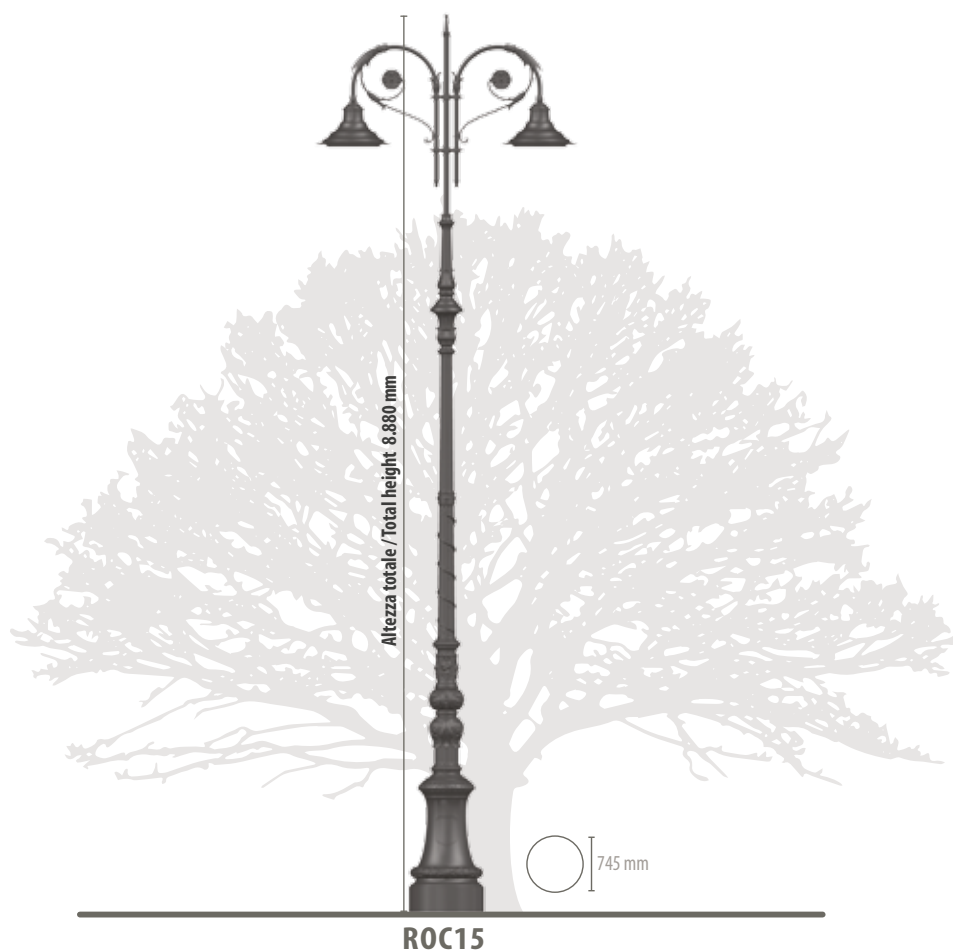

### **Versioni Disponibili // Available Versions**

Tipo di fissaggio: flangia o fondazione / Fixing type: flange or foundation  
 Sul palo è possibile installare a scelta un modello di PASTORALE LARGE p. 570 /  
 On the pole, the customer can choose to install a LARGE POLE ARM model p. 570



**illuminazione artistica // classic lighting**







## 25 CAST-IRON POLE-TOP SYSTEM [S]

“25” è un sistema cima-palo caratterizzato da un delicato decoro floreale. La raffinatezza dell'apparato decorativo completa con eleganza il palo in ghisa in cui viene inserito.

*“25” is a pole-top system which features a delicate floral decoration. The sophistication of the decorative element elegantly completes the cast iron pole in which it is inserted.*

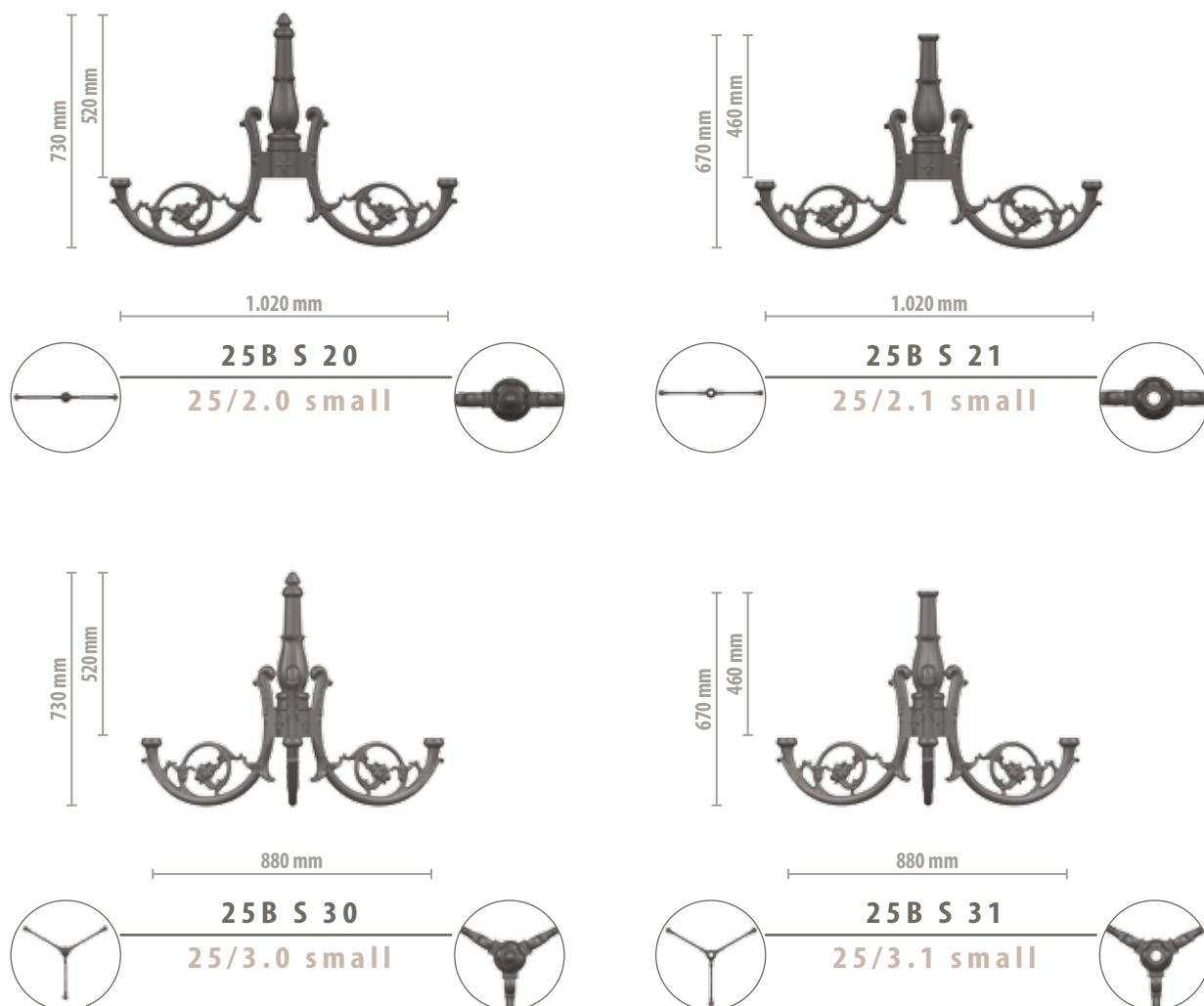

### Versioni Disponibili // Available Versions

Installabili su pali SS-ALM / Installable on poles SS-ALM

2.0 due corpi illuminanti laterali / 2.0 two side light fixtures

2.1 due corpi illuminanti laterali e uno testa-palo / 2.1 two side light fixtures and one pole-top

3.0 tre corpi illuminanti laterali / 3.0 three side light fixtures

3.1 tre corpi illuminanti laterali e uno testa-palo / 3.1 three side light fixtures and one pole-top





**25 CAST-IRON POLE-TOP SYSTEM [L]**

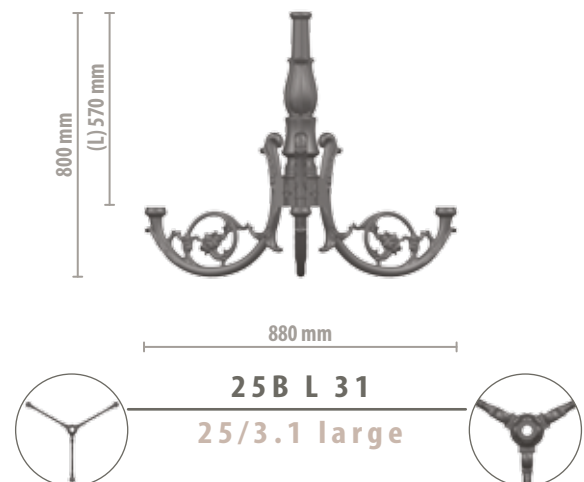
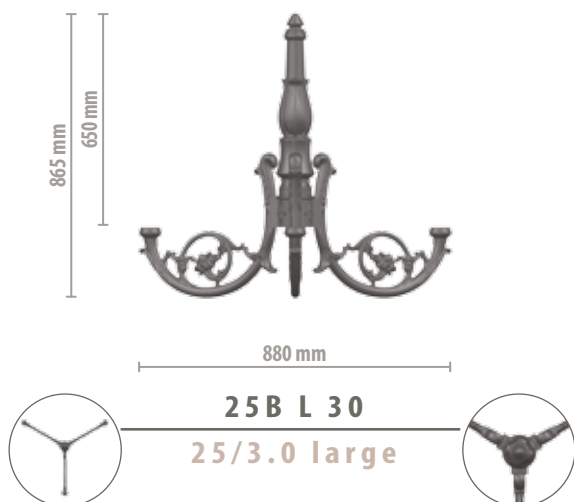
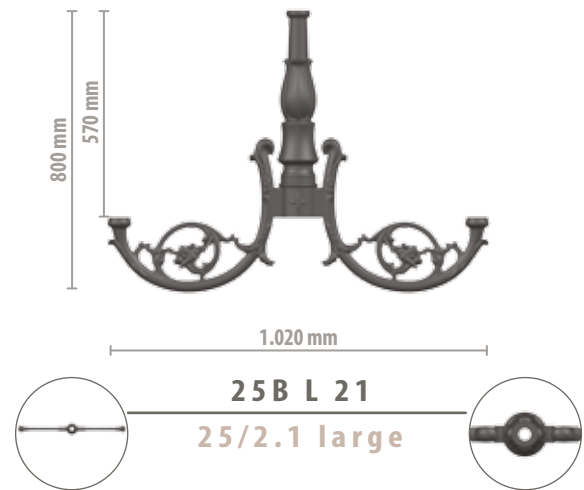
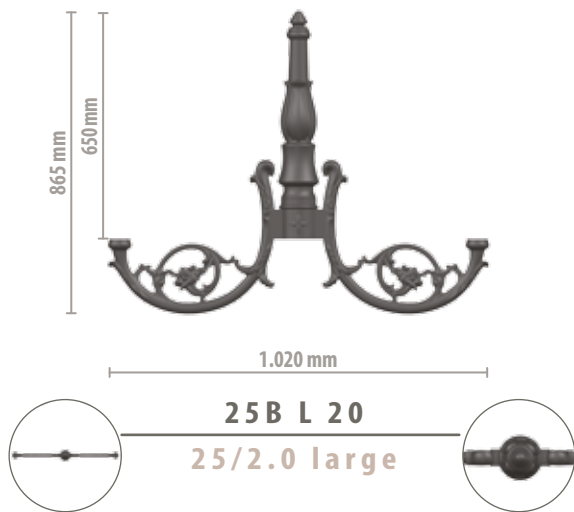

**Versioni Disponibili // Available Versions**

Installabili su pali SC-ALM · SL-ALM / Installable on poles SC-ALM · SL-ALM

2.0 due corpi illuminanti laterali / 2.0 two side light fixtures

2.1 due corpi illuminanti laterali e uno testa-palo / 2.1 two side light fixtures and one pole-top

3.0 tre corpi illuminanti laterali / 3.0 three side light fixtures

3.1 tre corpi illuminanti laterali e uno testa-palo / 3.1 three side light fixtures and one pole-top





### 30 CAST-IRON POLE-TOP SYSTEM [S]

“30” è un sistema cima-palo dalla linea sobria ed equilibrata. La semplicità della mensola esalta il design del palo in cui viene inserita, conferendogli un aspetto distinto.

“30” is a pole-top system with a sober and balanced style. The simplicity of the arm enhances the design of the pole in which it is inserted, giving it an elegant look.

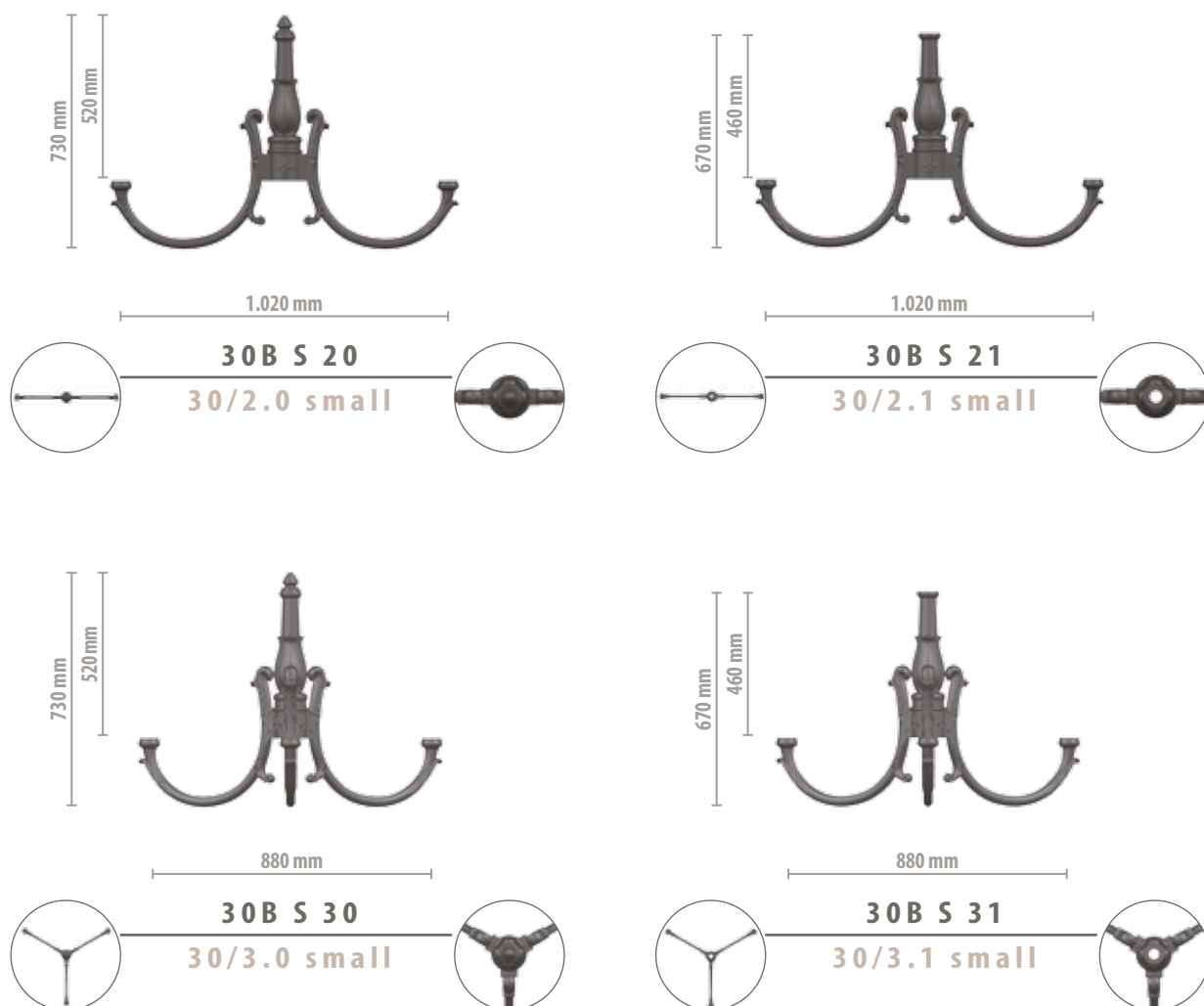

#### Versioni Disponibili // Available Versions

Installabili su pali SS-ALM / Installable on poles SS-ALM

- 2.0 due corpi illuminanti laterali / 2.0 two side light fixtures
- 2.1 due corpi illuminanti laterali e uno testa-palo / 2.1 two side light fixtures and one pole-top
- 3.0 tre corpi illuminanti laterali / 3.0 three side light fixtures
- 3.1 tre corpi illuminanti laterali e uno testa-palo / 3.1 three side light fixtures and one pole-top



**30 CAST-IRON POLE-TOP SYSTEM [L]**

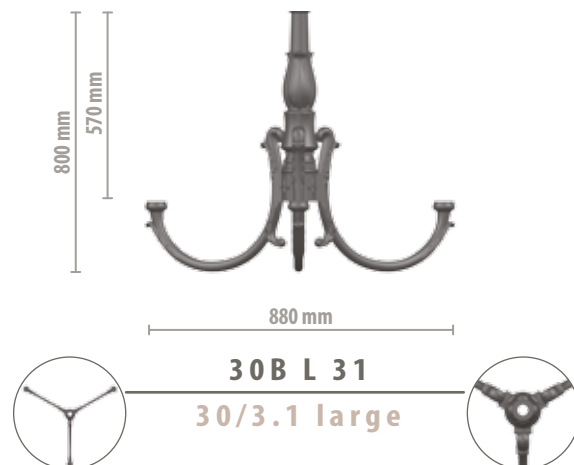
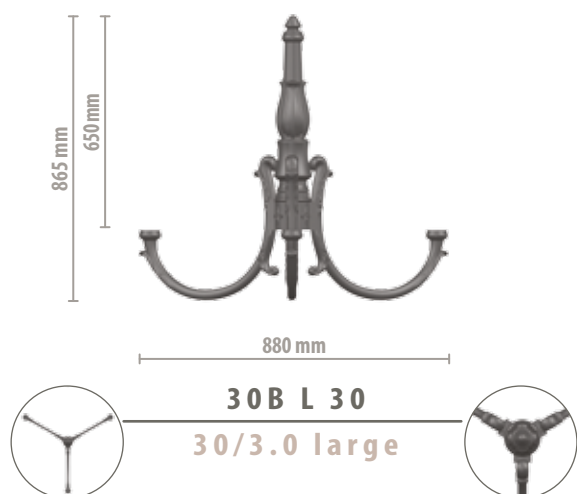
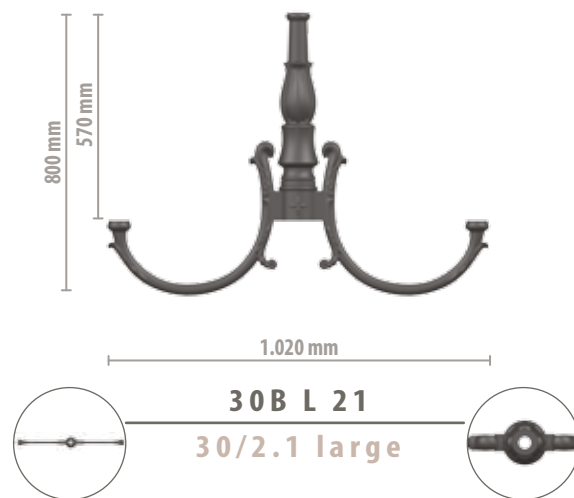
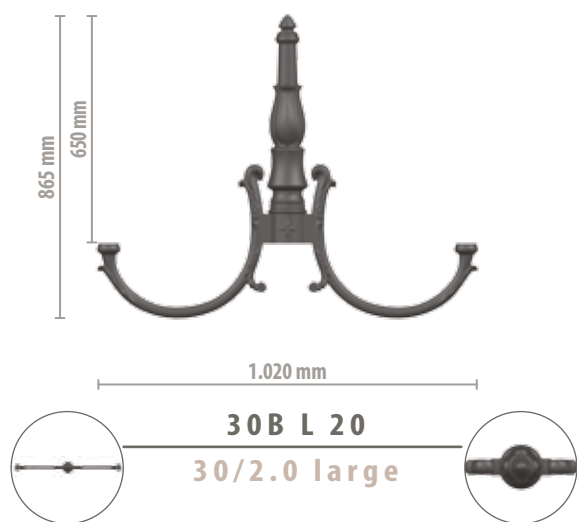

**Versioni Disponibili // Available Versions**

Installabili su pali SC-ALM · SL-ALM / Installable on poles SC-ALM · SL-ALM

2.0 due corpi illuminanti laterali / 2.0 two side light fixtures

2.1 due corpi illuminanti laterali e uno testa-palo / 2.1 two side light fixtures and one pole-top

3.0 tre corpi illuminanti laterali / 3.0 three side light fixtures

3.1 tre corpi illuminanti laterali e uno testa-palo / 3.1 three side light fixtures and one pole-top



**VENEZIA CAST-IRON POLE-TOP SYSTEM [S]**

“Venezia” è un sistema cima-palo di grande impatto, che trae ispirazione dai pali storici in ghisa dell’omonima città italiana. La cura dei dettagli decorativi e la finezza delle incisioni sono in grado di infondere uno spiccato carattere ornamentale al palo.

*“Venezia” is a striking pole-top system, drawing artistic inspiration from the cast iron poles found in the city of Venice. The care put in the decorative details and the exquisite engravings are able to instill a strong sense of character into the pole.*

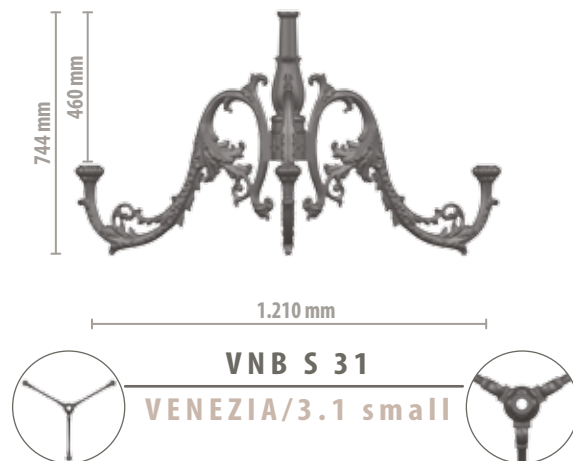
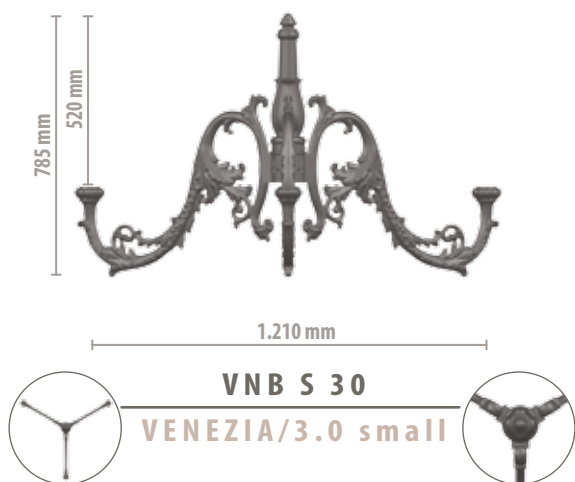
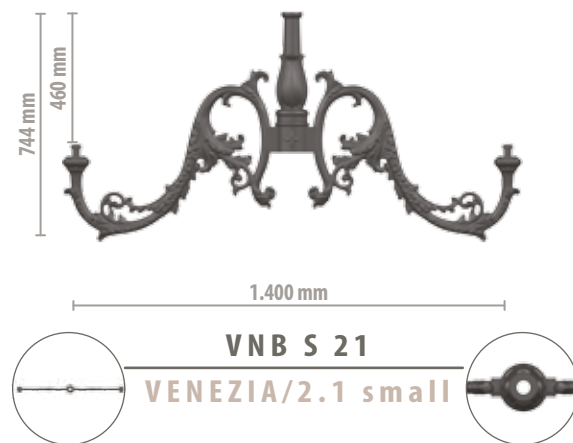
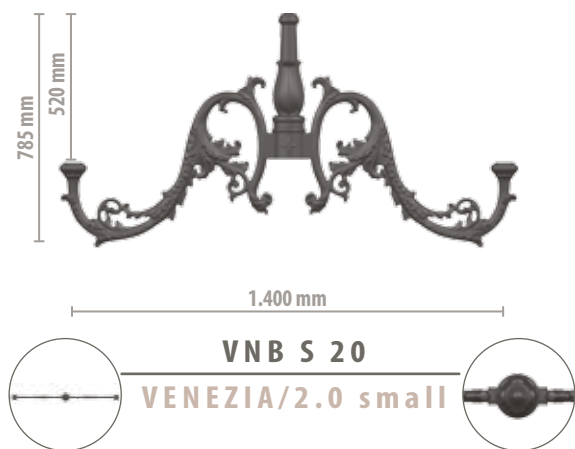

**Versioni Disponibili // Available Versions**

Installabili su pali SS-ALM / Installable on poles SS-ALM

- 2.0 due corpi illuminanti laterali / 2.0 two side light fixtures
- 2.1 due corpi illuminanti laterali e uno testa-palo / 2.1 two side light fixtures and one pole-top
- 3.0 tre corpi illuminanti laterali / 3.0 three side light fixtures
- 3.1 tre corpi illuminanti laterali e uno testa-palo / 3.1 three side light fixtures and one pole-top





**VENEZIA CAST-IRON POLE-TOP SYSTEM [L]**

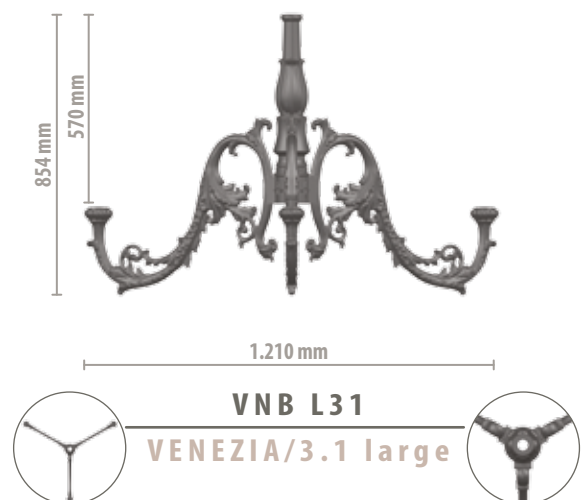
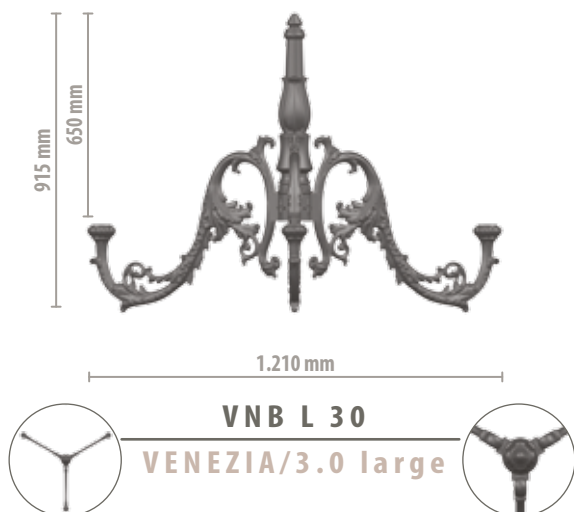
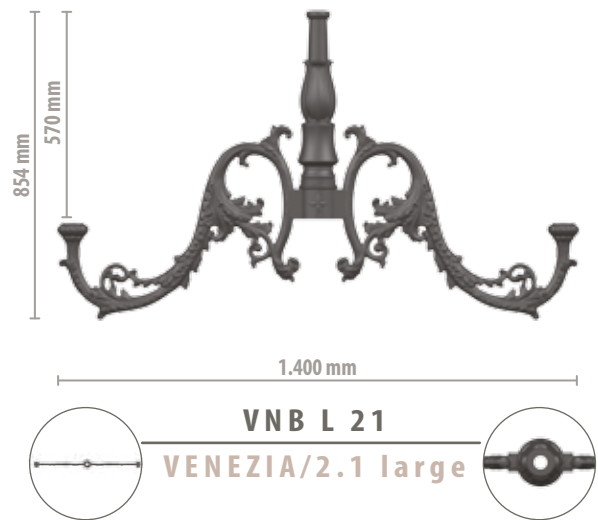
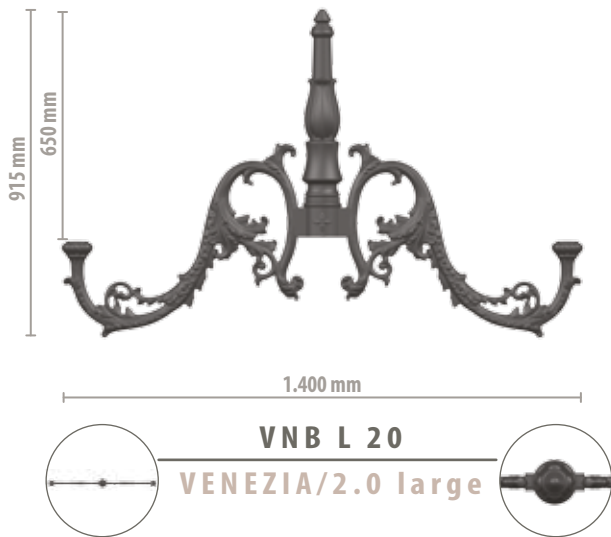

**Versioni Disponibili // Available Versions**

Installabili su pali SC-ALM · SL-ALM / Installable on poles SC-ALM · SL-ALM

2.0 due corpi illuminanti laterali / 2.0 two side light fixtures

2.1 due corpi illuminanti laterali e uno testa-palo / 2.1 two side light fixtures and one pole-top

3.0 tre corpi illuminanti laterali / 3.0 three side light fixtures

3.1 tre corpi illuminanti laterali e uno testa-palo / 3.1 three side light fixtures and one pole-top



**LP, VAL, IMC POLE ARMS**

“Lp”, “Val” e “Imc” compongono l’eclettica serie di pastorali della collezione ghisa.

“Lp”, “Val” and “Imc” make up the eclectic pole arms series which completes the cast iron poles collection.



(S) 1.063 mm • (L) 1.410 mm

(S) 735 mm • (L) 934 mm

**LPS S (small) • LPS L (large)**

**LP**



(S) 1.088 mm • (L) 1.409 mm

(S) 871 mm • (L) 1.131 mm

**VLS S (small) • VLS L (large)**

**VAL**

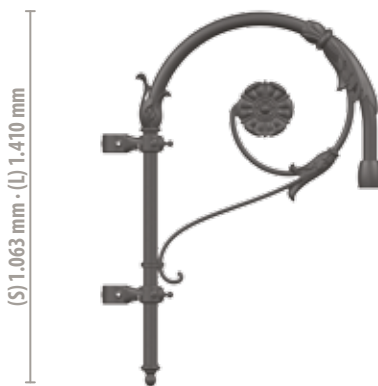

(S) 1.063 mm • (L) 1.410 mm

(S) 735 mm • (L) 934 mm

**IMS S (small) • IMS L (large)**

**IMC**

**Versioni Disponibili // Available Versions**

Pastorali SMALL disponibili in versione singola o doppia su pali SS-ALP / SMALL pole arms available in single or double versions on SS-ALP poles

Pastorali LARGE disponibili in versione singola, doppia, tripla o quadrupla su pali SL-ALP /

LARGE pole arms available in single, double, triple or quad versions on SL-ALP poles

# Regole di Composizione // Composition Rules

## Corpo illuminante testa-palo Pole-top light fixture

vedi capitolo  
"corpi illuminanti artistici"  
refer to "classical light  
fixtures" chapter



**ALC 10**

CAPITELLO PER CORPO ILLUMINANTE TESTA-PALO  
CAPITAL FOR POLE-TOP LIGHT FIXTURE

## Corpo illuminante testa-palo Pole-top light fixture

vedi capitolo  
"corpi illuminanti artistici"  
refer to "classical light  
fixtures" chapter

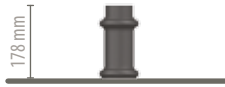

**ALM 10**

CAPITELLO PER SISTEMA CIMA-PALO  
CAPITAL FOR POLE-TOP SYSTEM

## Corpo illuminante a sospensione Suspended light fixture

vedi capitolo  
"corpi illuminanti artistici"  
refer to "classical light  
fixtures" chapter

## Pastorale Small Small pole arm

p. 570  
Pastorale singolo o doppio  
Single or double pole arm

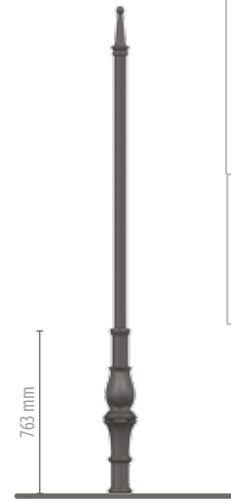

**ALP 10**

CAPITELLO PER PALO CON PASTORALI  
CAPITAL FOR POLE WITH ARMS

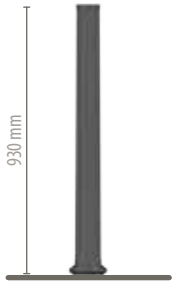

**NS 10**

COLONNE PER CORPO ILLUMINANTE TESTA-PALO  
COLUMNS FOR POLE-TOP LIGHT FIXTURE

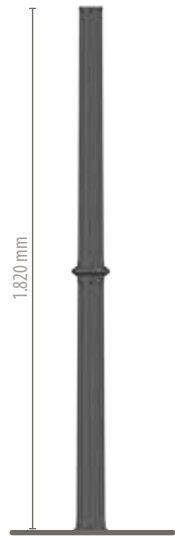

**SS 10**

COLONNA PER SISTEMA CIMA-PALO  
COLUMN FOR POLE-TOP SYSTEM

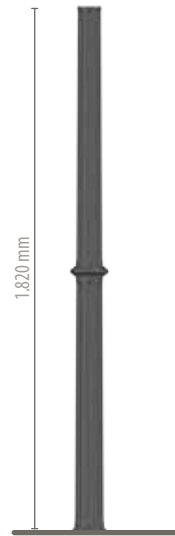

**SS 10**

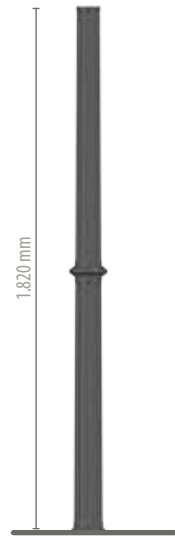

**SS 10**

COLONNA PER PALO CON PASTORALI  
COLUMN FOR POLE WITH ARMS



**OVULI 10 FL**  
p. 516

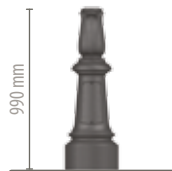

**BERTY 10 FL**  
p. 522

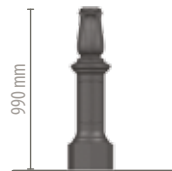

**CAR 10 FL**  
p. 528



**CQC 10 FL**  
p. 538

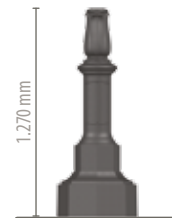

**CARSB 10 FL**  
p. 532

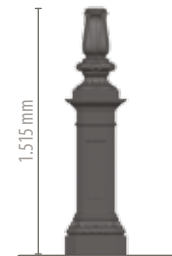

**QU 10 FL**  
p. 544

BASI A SCELTA PER PALI [10] • AVAILABLE POLE BASES [10]

**Corpo illuminante testa-palo**  
**Pole-top light fixture**

vedi capitolo  
"corpi illuminanti artistici"  
refer to "classical light  
fixtures" chapter

**Sistemi cima-palo Large**  
**Large pole-top systems**  
pp. 560 - 564 - 568



**ALM 12**

**CAPITELLO PER SISTEMA CIMA-PALO**  
**CAPITAL FOR POLE-TOP SYSTEM**

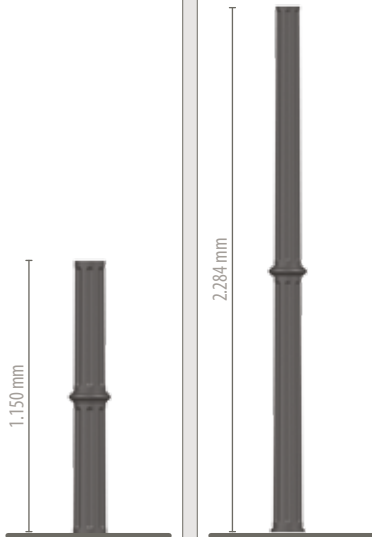

**SC 12**

**SL 12**

**COLONNA PER SISTEMA CIMA-PALO**  
**COLUMN FOR POLE-TOP SYSTEM**

**Corpo illuminante a sospensione**  
**Suspended light fixture**

vedi capitolo  
"corpi illuminanti artistici"  
refer to "classical light  
fixtures" chapter

**Pastorale Large**  
**Large pole arm**  
p. 570

Pastorale singolo, doppio,  
triplo o quadruplo  
Single, double, triple  
or quad pole arm

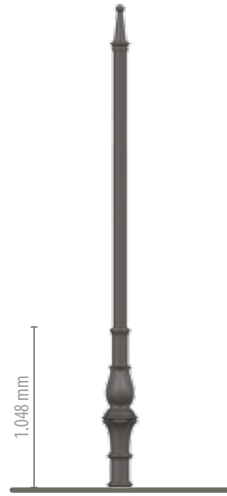

**ALP 12**

**CAPITELLO PER PALO CON PASTORALI**  
**CAPITAL FOR POLE WITH ARMS**

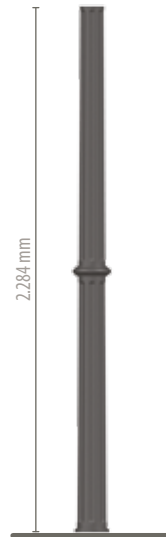

**SL 12**

**COLONNA PER PALO CON PASTORALI**  
**COLUMN FOR POLE WITH ARMS**

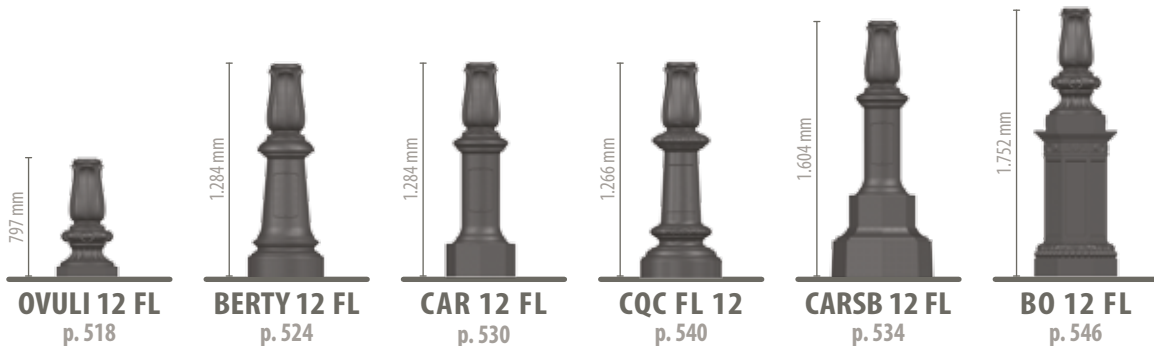

**OVULI 12 FL**  
p. 518

**BERTY 12 FL**  
p. 524

**CAR 12 FL**  
p. 530

**CQC FL 12**  
p. 540

**CARSB 12 FL**  
p. 534

**BO 12 FL**  
p. 546



**illuminazione artistica // classic lighting**









## 25, 30 CAST-IRON WALL BRACKETS

La forma arcuata caratterizza le mensole a muro "25" e "30", disponibili per corpi illuminanti a portata.

*The curved shape characterises the "25" and "30" wall bracket, available for upright light fixtures.*

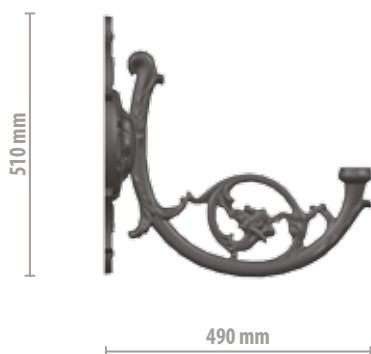

**25 W**

25

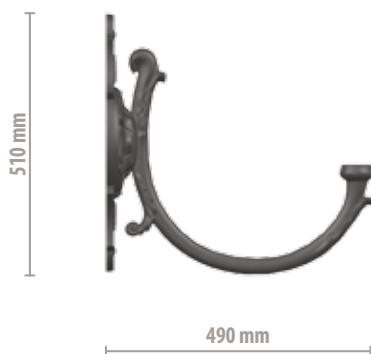

**30 W**

30



## VENEZIA CAST-IRON WALL BRACKET

Al pari dell'omonimo sistema cima-palo, la mensola a muro "Venezia" si distingue per decoratività ed eleganza. Disponibile in un'unica versione, può essere completata con corpi illuminanti a portata.

*On a par with the homonymous pole-top system, the "Venezia" wall bracket stands out itself for its decoration and elegance. Available in one version, it can be completed with upright light fixtures.*



**VNW**

**VENEZIA**





## 50, CRIS CAST-IRON WALL BRACKETS

“50” e “Cris” si caratterizzano per i delicati decori floreali. Le mensole sono disponibili in doppia versione, per corpi illuminanti a portata e a sospensione.

*The “50” and “Cris” wall brackets are characterised by the delicate floral decorations. The bracket are available in two versions, one for upright and the other for suspended light fixtures.*

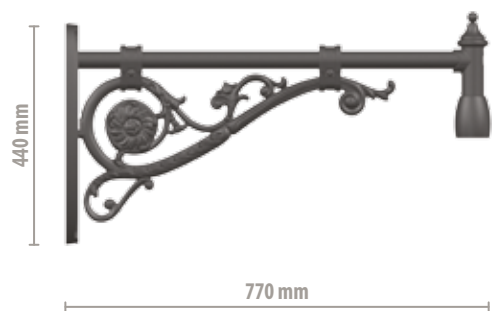

**50 W A**

50 A

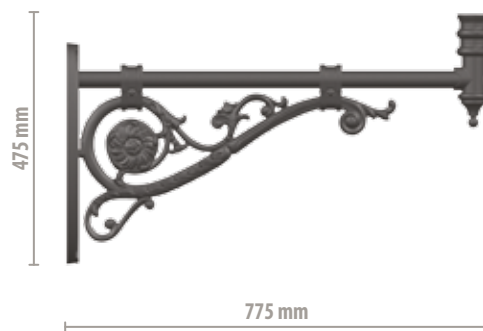

**50 W C**

50 C

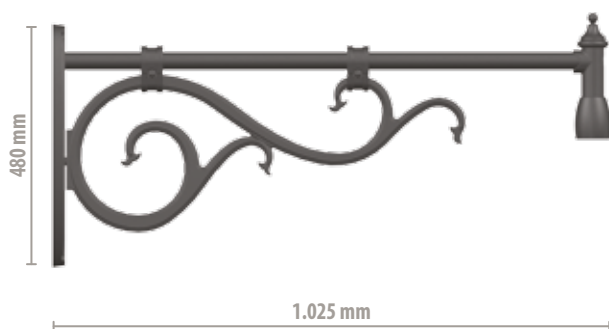

**CRW A**

CRIS A

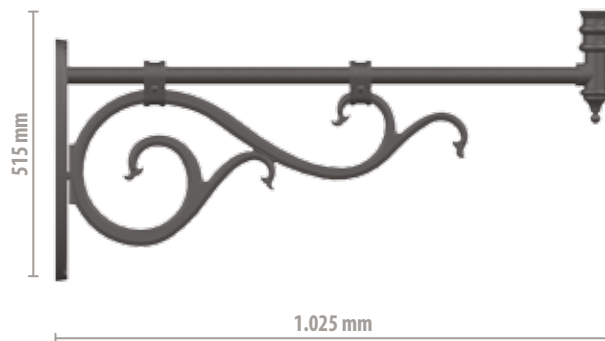

**CRW C**

CRIS C



## 1864, 1861 CAST-IRON WALL BRACKETS

“1864” e “1861” sono mensole a muro dagli aggraziati decori, particolarmente indicate per contesti storici. Sono disponibili per corpi illuminanti a portata e a sospensione.

*“1864” and “1861” are gracefully decorated wall bracket, particularly recommended in historical contexts. The brackets are available for both upright and suspended light fixtures.*

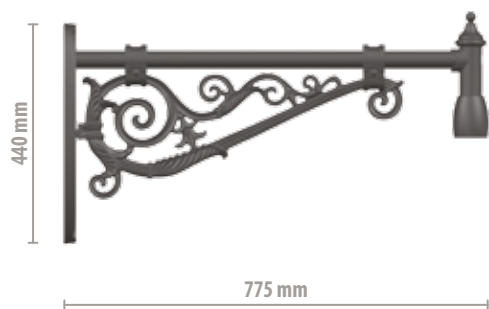

**64 W A**

**1864 A**

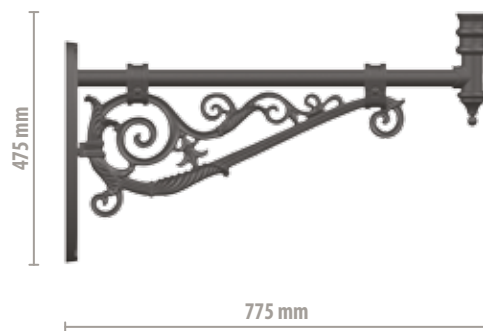

**64 W C**

**1864 C**

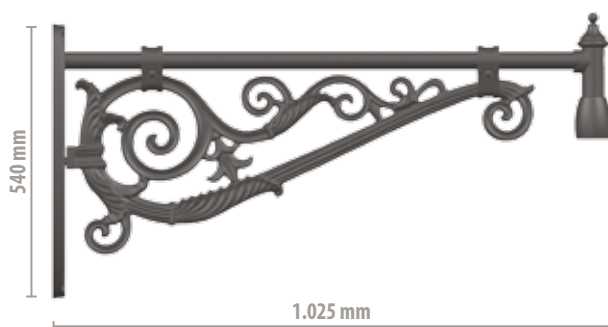

**61 W A**

**1861 A**

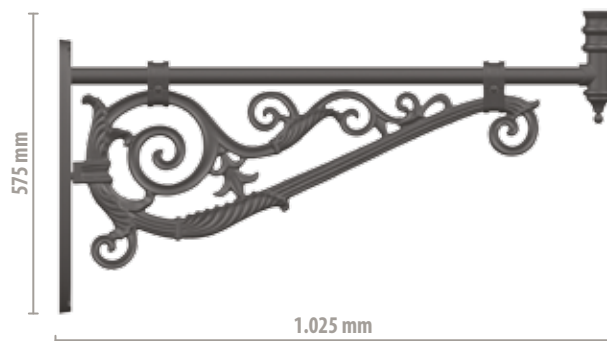

**61 W C**

**1861 C**



**illuminazione artistica // classic lighting**











**Illuminazione artistica //**  
*classic lighting*

**ATTACCHI A SOFFITTO //** *ceiling suspension systems*

588

**CHANDELIER**

592

**25, 30, VENEZIA CANDELABRA**

---

# attacchi a soffitto

## *ceiling suspension systems*

Una raccolta di sistemi a sospensione in stile classico per illuminare con eleganza soffitti, volte e portici.

*A collection of classic style suspension systems to elegantly decorate ceilings, vaults and porticoes.*



## CHANDELIER

GMR ENLIGHTS propone due soluzioni che, con estrema semplicità, consentono l'attacco a soffitto di una luce con tubo di acciaio o catena.

*GMR ENLIGHTS offers two solutions to easily attach a lighting fixture to the ceiling using a steel tube or chain.*

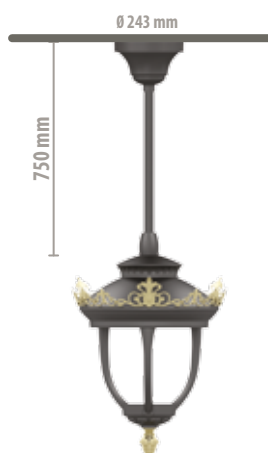

### **Attacco con Tiges / Ceiling mounting with steel tube**

**TIH**



### **Attacco con Catena / Chain fixing**

**CAH**

**illuminazione artistica // classic lighting**









**25, 30, VENEZIA CANDELABRA**

"25", "30" e "Venezia" sono candelabri dal gusto romantico, realizzati con un sostegno centrale in acciaio e bracci decorati in fusione di alluminio.

"25", "30" and "Venezia" are romantic suspended candelabras with central support made in steel and decorated arms in cast aluminium

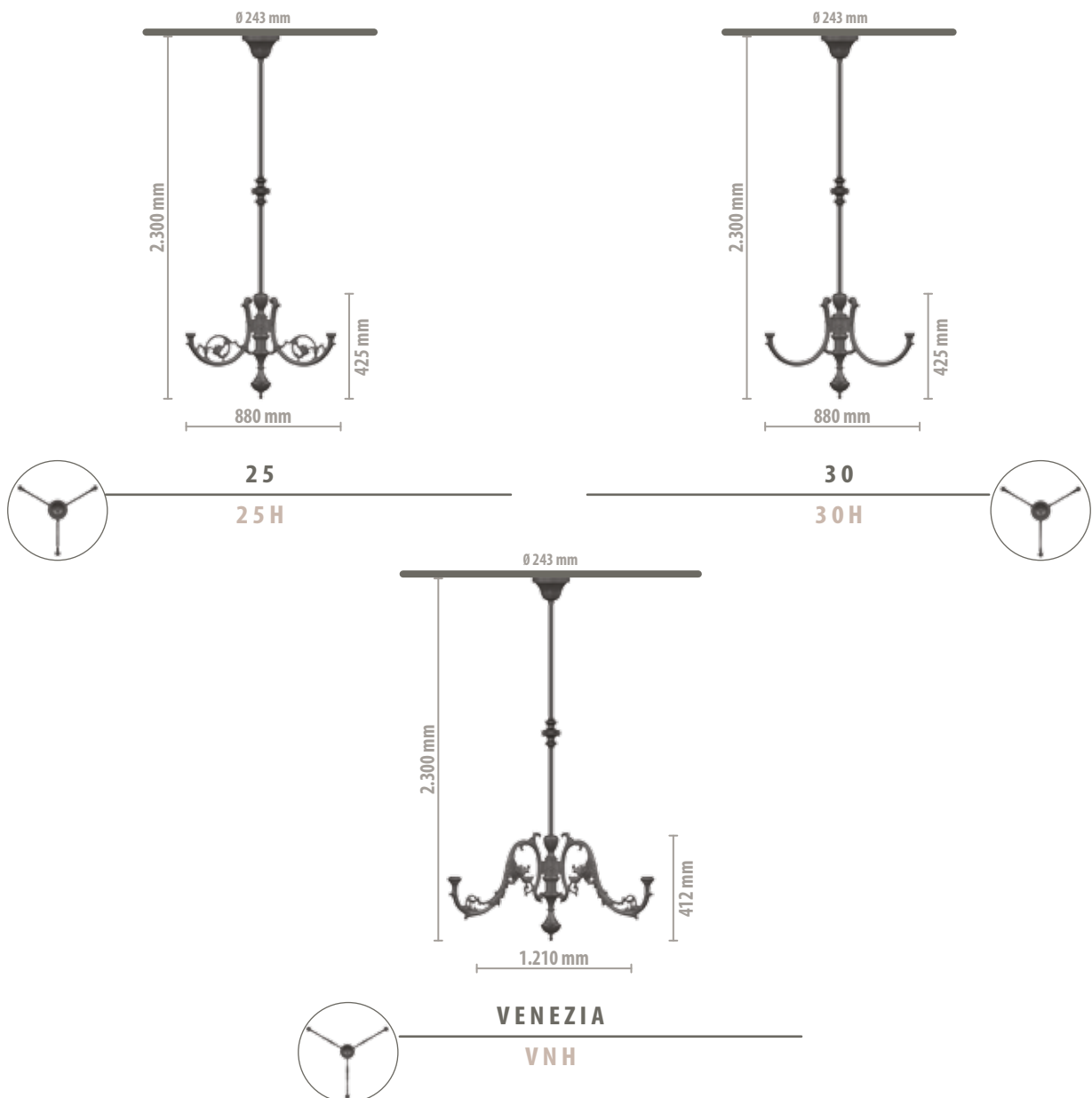

**illuminazione artistica // classic lighting**







**Illuminazione artistica //**  
*classic lighting*

**BOLLARD / bollards**

598 **BELLI** BOLLARD

602 **VIGO** BOLLARD

---

# **bollard in ghisa** *cast-iron bollards*

Piccole sculture in ghisa plasmate dalla morbidezza della luce per delimitare i percorsi e nobilitare lo spazio urbano.

*Small cast-iron sculptures moulded by the softness of the light to border routes and add prestige to the urban environment.*





## BELLI BOLLARD

Un pesante guscio in ghisa che custodisce la leggerezza della luce: un'Unione elegante, che rende "Belli" un oggetto unico.

*A heavy cast iron shell which protects the lightness of light: an elegant combination which makes "Belli" a unique item.*

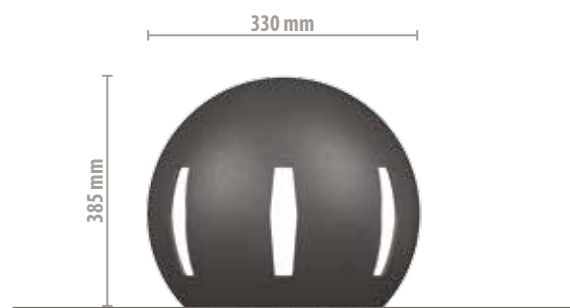

**BEG**

### Specifiche Tecniche // Technical Features

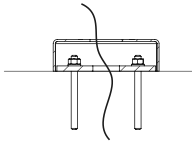
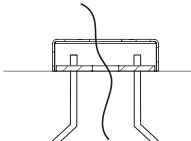
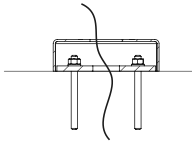
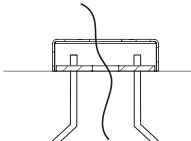
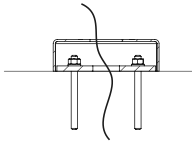
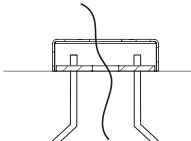
<p><b>MATERIALE:</b> fusione di ghisa, schermo in PMMA.</p>	<p><b>MATERIAL:</b> cast-iron, PMMA screen.</p>	<p><b>COMPACT</b> Apparecchio sigillato, fornito con connettore rapido per installazione immediata. <i>Sealed fixture with short power cable and IP electrical connector for a quick and simple linkage to the mains.</i></p>				
<p><b>COLORI DISPONIBILI: BLU, ROSSO, VERDE E BIANCO</b> <i>AVAILABLE COLOURS: BLUE, RED, GREEN AND WHITE</i></p>						
<p><b>SISTEMI OTTICI // OPTICAL SYSTEMS</b></p>		<p><b>TIPO DI FISSAGGIO // FIXING TYPE</b></p>				
<p> • 6 360° •</p>		<table border="1"> <tr> <td data-bbox="810 1499 1050 1749">  </td> <td data-bbox="1050 1499 1286 1749">  </td> </tr> <tr> <td data-bbox="810 1749 1050 1804"> <p><b>FLANGIA // FLANGE</b></p> </td> <td data-bbox="1050 1749 1286 1804"> <p><b>FONDAZIONE // FOUNDATION</b></p> </td> </tr> </table>			<p><b>FLANGIA // FLANGE</b></p>	<p><b>FONDAZIONE // FOUNDATION</b></p>
						
<p><b>FLANGIA // FLANGE</b></p>	<p><b>FONDAZIONE // FOUNDATION</b></p>					

**illuminazione artistica // classic lighting**











## VIGO BOLLARD



Design: Ing. Arch. Paolo Ceredi, Arch. Francesco Ceredi

“Vigo” è una spirale in ghisa che si avvolge delicatamente per proteggere il tesoro più prezioso: la luce.

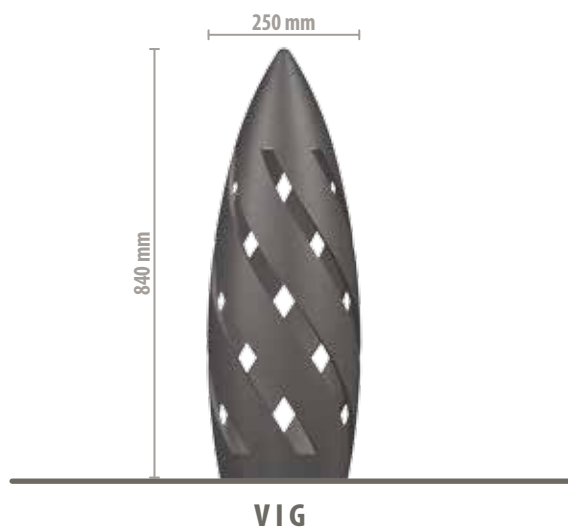
“Vigo” is a cast iron spiral which delicately wraps around itself to protect the most precious treasure: light.

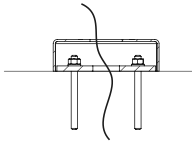
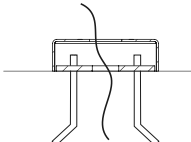

### Specifiche Tecniche // Technical Features

<b>MATERIALE:</b> fusione di ghisa.	<b>MATERIAL:</b> cast-iron.	 <b>COMPACT</b> Apparecchio sigillato, fornito con connettore rapido per installazione immediata. Sealed fixture with short power cable and IP electrical connector for a quick and simple linkage to the mains.	
<b>TEMPERATURA DI COLORE // COLOUR TEMPERATURE</b> 2200K // 3000K // 4000K // 5700K		<b>TIPO DI FISSAGGIO // FIXING TYPE</b>	
<b>SISTEMI OTTICI // OPTICAL SYSTEMS</b>  • 6360° •			
		<b>FLANGIA // FLANGE</b>	<b>FONDAZIONE // FOUNDATION</b>



**illuminazione artistica // classic lighting**











GMR ENLIGHTS si riserva di apportare eventuali modifiche utili al miglioramento e aggiornamento dei prodotti in qualsiasi momento e senza alcun preavviso.

*GMR ENLIGHTS reserves the right to make, at any time and without prior notice, any modifications aimed at improving or updating its products.*

**Technology Partners**

Art Direction / Graphic Layout: Noemi Venzi  
3D Rendering: Luca Franchini

Copyright © 2020 GMR ENLIGHTS





Via Grande, 226 • 47032 Bertinoro [FC] • ITALY  
phone +39 0543 462611 • fax +39 0543 449111  
[info@gmrenlights.com](mailto:info@gmrenlights.com) [www.gmrenlights.com](http://www.gmrenlights.com)

Certified company as per  
ISO 9001: 2015 / ISO 14001 : 2015

Copyright © 2020 GMR ENLIGHTS - IT / UK

